



M-1504

Material lift

Planning
Guide

 savaria.

Applicable Codes:

ASME B20.1

ASME A17.1 - 7.4, 5, 6 Type B

Copyright © 2020
Savaria Concord Lifts, Inc.
All rights reserved.

Printed in Canada

Purpose of This Guide

This guide assists architects, contractors, and lift professionals to incorporate the M-1504 Material Lift into a residential or public building design. The design and manufacture of the M-1504 Material Lift meets the requirements of the following codes and standards:

- ASME B20.1
- ASME A17.1 - 7.4, 5, 6 Type B

We recommend that you contact your local authority having jurisdiction to ensure that you adhere to all local rules and regulations pertaining to material lifts.

IMPORTANT: This Planning Guide provides nominal dimensions and specifications useful for the initial planning of a material lift project. Dimensions and specifications are subject to change without notice due to continually evolving code and product applications.

Before beginning actual construction, please consult Savaria or the authorized Savaria dealer in your area to ensure you receive your site-specific installation drawings with the dimensions and specifications for your project.

Visit our website for the most recent M-1504 drawings and dimensions.

How to Use This Guide

- 1 Determine your client's intended use of the lift.
- 2 Determine the local code requirements.
- 3 Determine the site installation parameters.
- 4 Determine the cab type and hoistway size requirements.
- 5 Plan for electrical requirements.

History

September 29, 2015 - Initial release

October 9, 2015 - Revised layout drawings on pages 11 and 12

March 29, 2016 - Revised layout drawings on pages 11 and 12

June 14, 2016 - Added 6" pit depth for A17.1 code to spec table on page 4

August 8, 2016 - Revised title page and Specifications on page 4

February 16, 2017 - Added temperature spec to specs table on page 4

July 5, 2017 - Changed Type A to Type B in code above

August 22, 2017 - Added note re: bracket screws to Site Construction Details on page 6

March 27, 2018 - Revised speed spec on page 4 to say Nominal Speed

October 2, 2018 - Revised nominal speed on page 4 to 18 fpm

February 11, 2019 - Removed reference to Type 3 and 4 cab on page 10

March 4, 2019 - Revised drawings on page 10

January 15, 2020 - Added Savaria Link option to specs table on page 5 and to provisions by others on page 23

June 08, 2022 - Updated measurements for remote controller on page 46

August 02, 2022 - Updated cover

Specifications

M-1504 Specifications

Specification	Specification Data
Load capacity	1000 lb (455 kg)
Maximum travel	23 ft (7 m) for B20.1 200 inches (508 cm) for A17.1
Nominal speed	18 ft/min (0.09 m/s)
Temperature	Indoor: +5 °F to +122 °F (-15 °C to +50 °C) Outdoor: -20 °F to +122 °F (-29 °C to +50 °C)
Noise level (for typical installation)	72.9 dBA (up direction); 50.0 dBA (down direction) Measured at a height of 1m, distance of 1m, in front of the motor with all panels on
Daily cycle	Normal: 30 Heavy: 75 Excessive: 100 Maximum starts in 1 hour on standard installation: 12 NOTE: Please consult your Sales Representative if there a chance you may exceed these amounts.
Levels serviced	2 (standard), 3, 4 Note: For A17.1, can only penetrate one floor.
Cab sizes	36" x 54" (914 mm x 1371 mm) 42" x 60" (1067 mm x 1524 mm) 48" x 60" (1219 mm x 1524 mm)
Cab walls (height)	Standard 60" (1524 mm) for B20.1 Standard 80" (2031 mm) for A17.1
Cab access	Enter/exit same side (platform Type 1L and 1R) Front/rear access (platform Type 2)
Power supply	120 VAC, 30 A, 60 Hz, single phase
Motor/drive	2:1 chain hydraulic, 3 HP, gear-type motor for 110V
Control system	Electronic-free relay logic controller
Tower	Modular 8 ft (2.4 m) base guide rail assembly Roller guide support
Pit depth requirement	3" (76.2 mm); 8" (203.2 mm) with habitable space underneath 6" (152.4 mm) for A17.1 code
Finish	Grey electrostatic powder coat paint on frame Stainless steel on walls
Standard features	24 VDC operation Call/send stations at landings Continuous-pressure type buttons Operating control buttons on platform Automatic battery recharging system (115VAC) Remote manual lowering device Low-voltage controls Limit switches Stainless steel checkered platform surface No machine room required Emergency stop button
Safety features	Bottom and top landing door Door locks Safety brake Emergency stop buttons Manual lowering and battery lowering system Pit prop (for A17.1) Solid buffer (for A17.1) Oil temperature sensor (for A17.1)

M-1504 Specifications

Specification	Specification Data
Options	Fire-rated, flush-mounted landing entrances Custom color Outdoor package 24V battery backup Remote controller/pump box Savaria Link remote monitoring

Site Construction Details

The M-1504 needs a wall that supports a minimum of 650 lb (2913 N) of pull out force at any bracket. Note that the brackets come with the proper hardware to secure them in place (1/2" x 3" lag screws for wood/drywall or 1/2" x 4-1/4" anchor wedge screws for concrete walls). The floor must be capable of supporting a load of 3400 lb (15.2 kN). See Figure 1. A wall with a combination of two columns of three 2x4's, or a concrete or brick wall is required.

Figure 2 details a sample wooden support wall configuration

Figure 1: Wall/Floor Loading

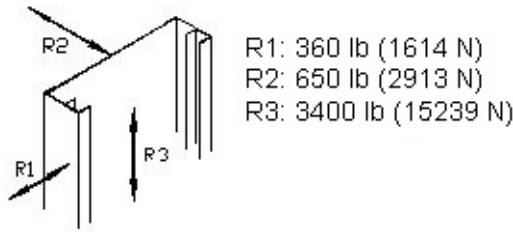

Figure 2: Sample Wooden Support Wall Configuration

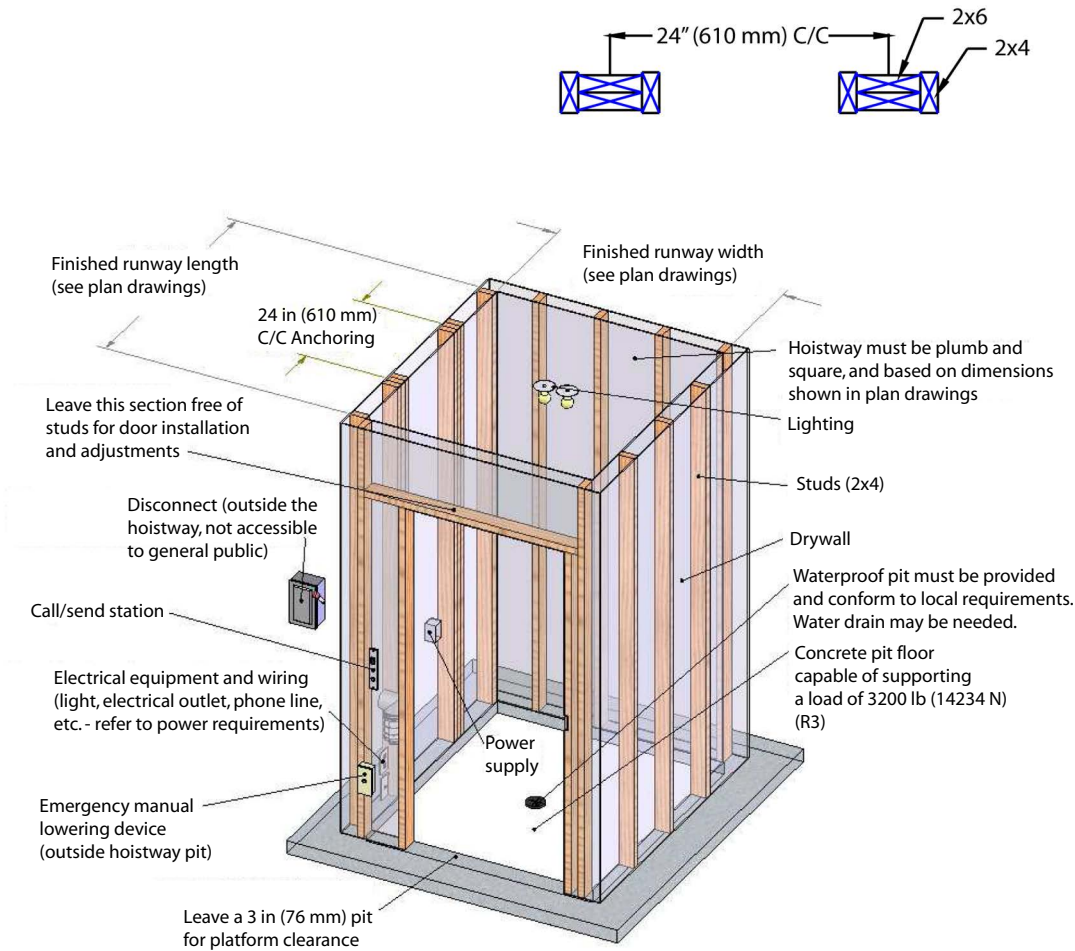

Figure 3 illustrates the recommended steps for constructing a wooden hoistway.

Figure 3: Wooden Hoistway Construction - Recommended Steps

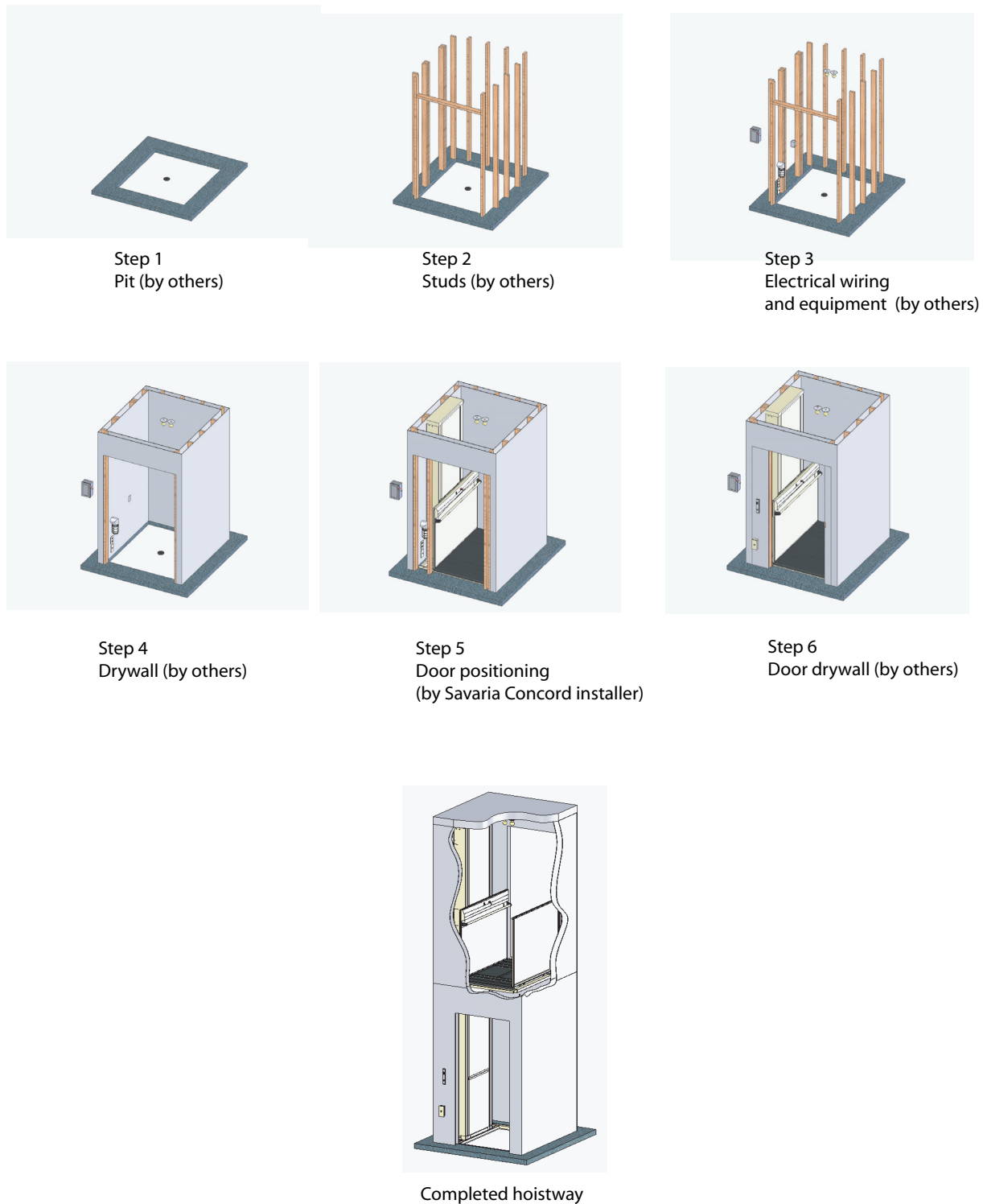

Figure 4 illustrates a sample outdoor enclosure application.

Figure 4: Sample Outdoor Enclosure Application

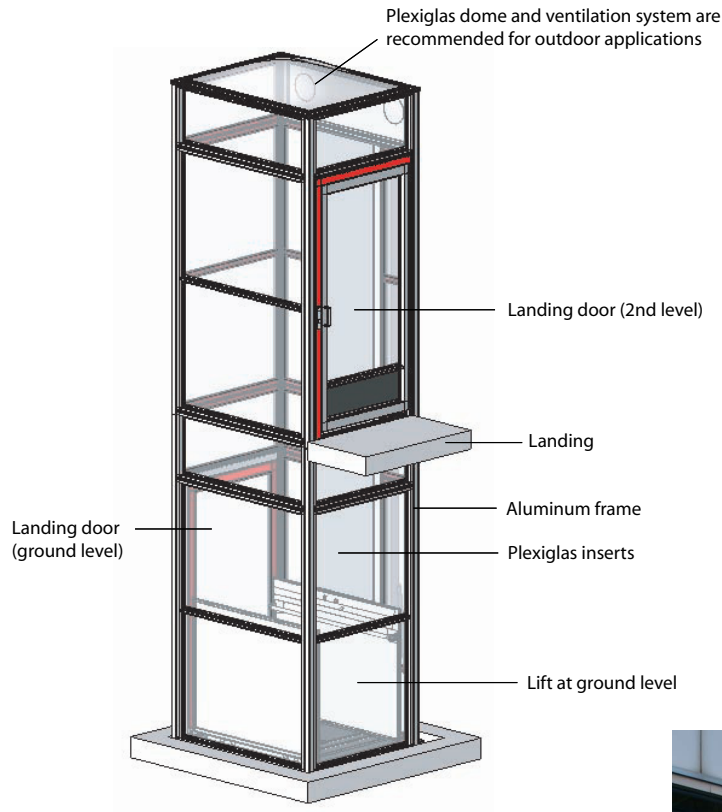
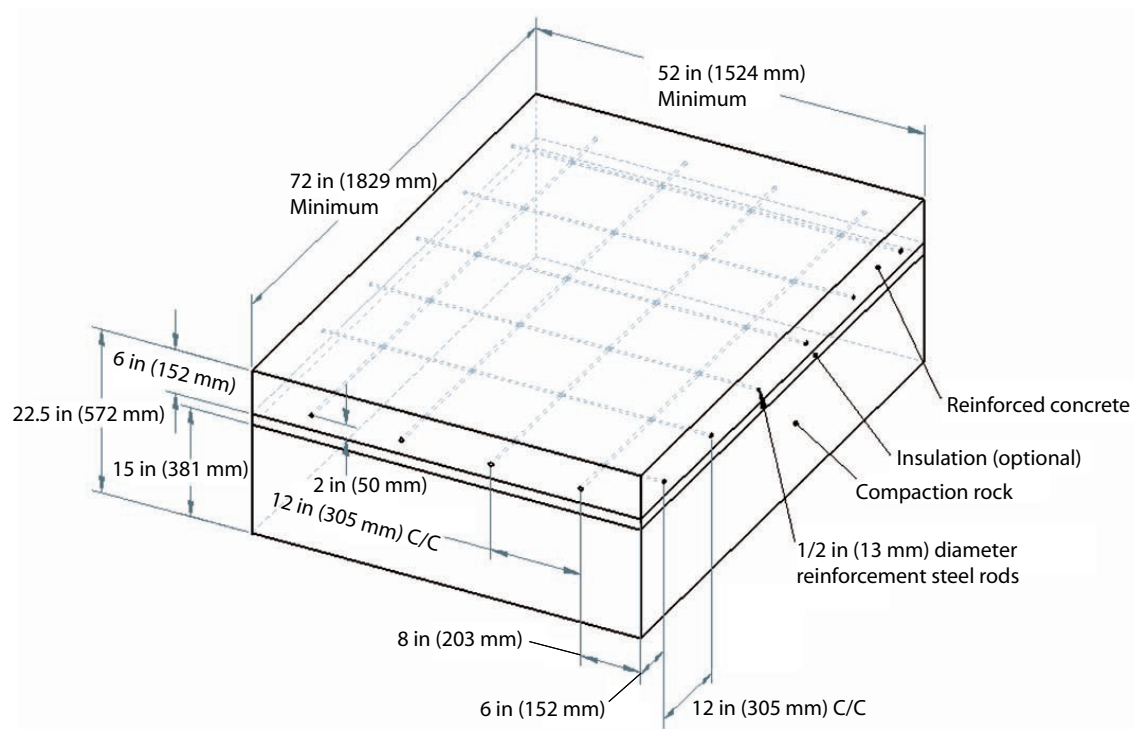

Figure 5 illustrates the concrete slab detail for a typical outdoor application.

Figure 5: Concrete Slab Detail



Cab Types

Type 1 Cabs

For type 1 cabs, entry and exit are available from only one end of the platform.

Figure 6: Type 1 Left and Right

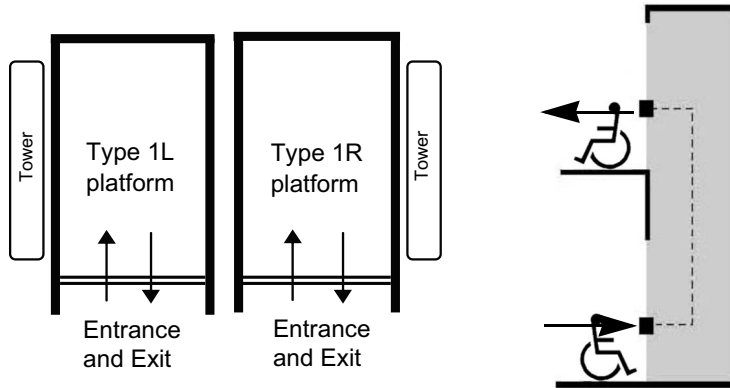

Type 2 Cabs

For type 2 cabs, entry and exit are available from both ends of the platform.

Figure 7: Type 2

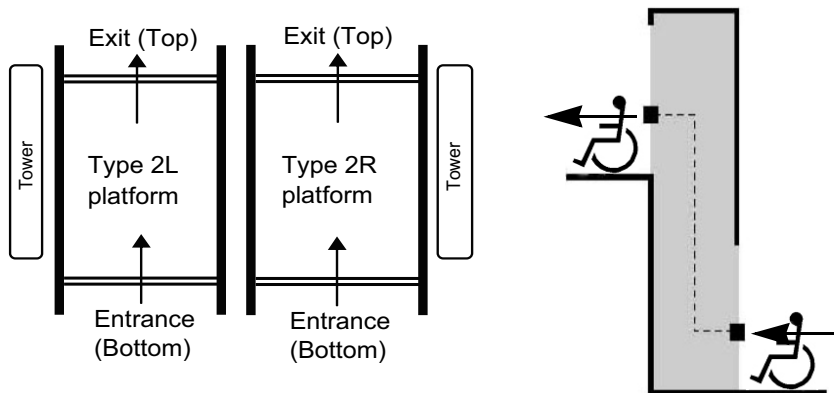

Drawings

- Elevation and plan view (Type 1L)
- Elevation and plan view (Type 2)
- Auto door, left-hand
- Auto door, right-hand
- Manual door, left-hand
- Manual door, right-hand
- Prodoor auto, left-hand
- Prodoor auto, right-hand
- Prodoor manual, left-hand
- Prodoor manual, right-hand
- Remote controller/pump box dimensions

Note: Refer to the Architects & Builders portion of our main website (www.savaria.com) for other door sizes.

Figure 8: Elevation and plan view (Type 1L)

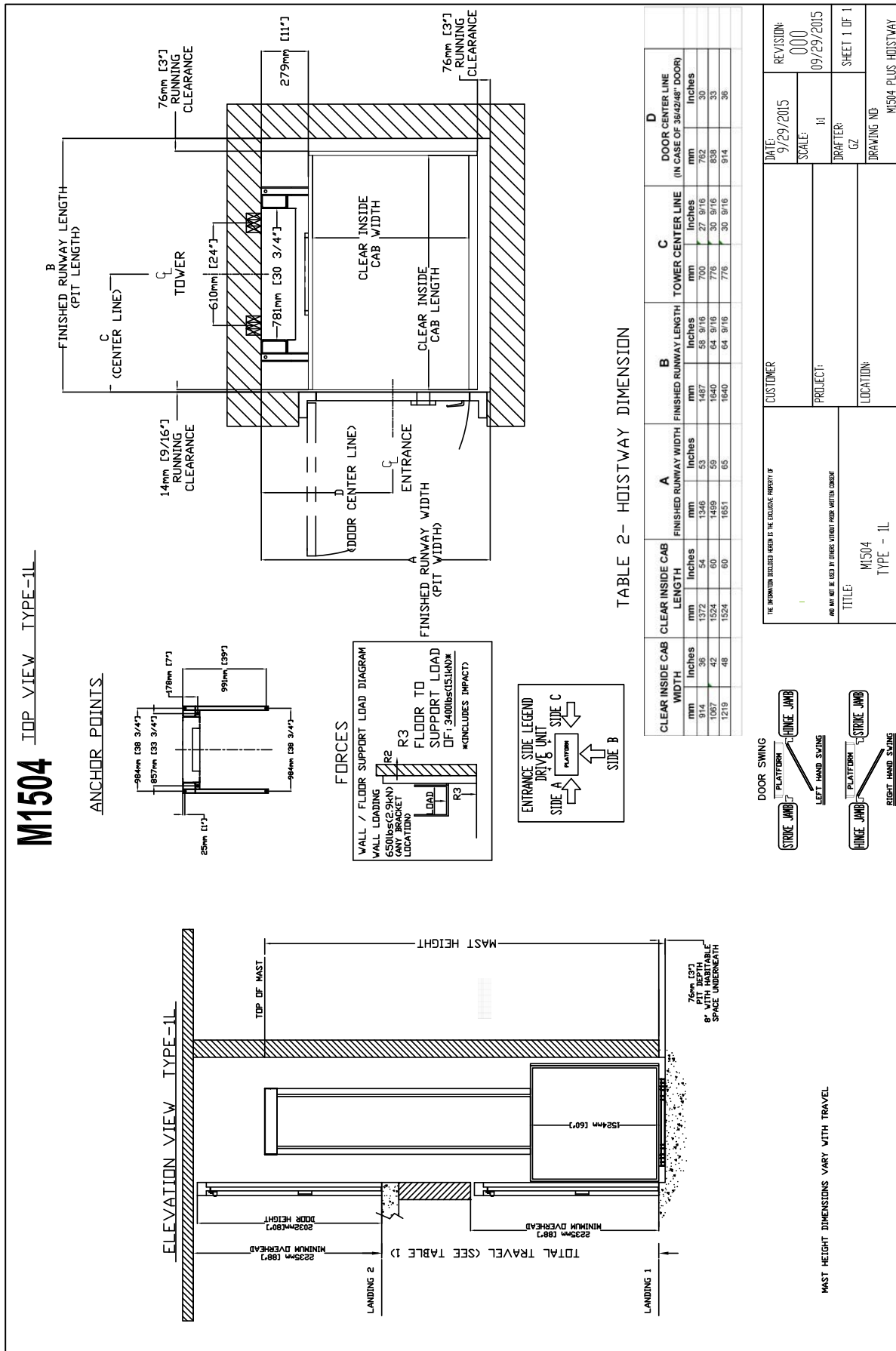

Figure 9: Elevation and plan view (Type 2)

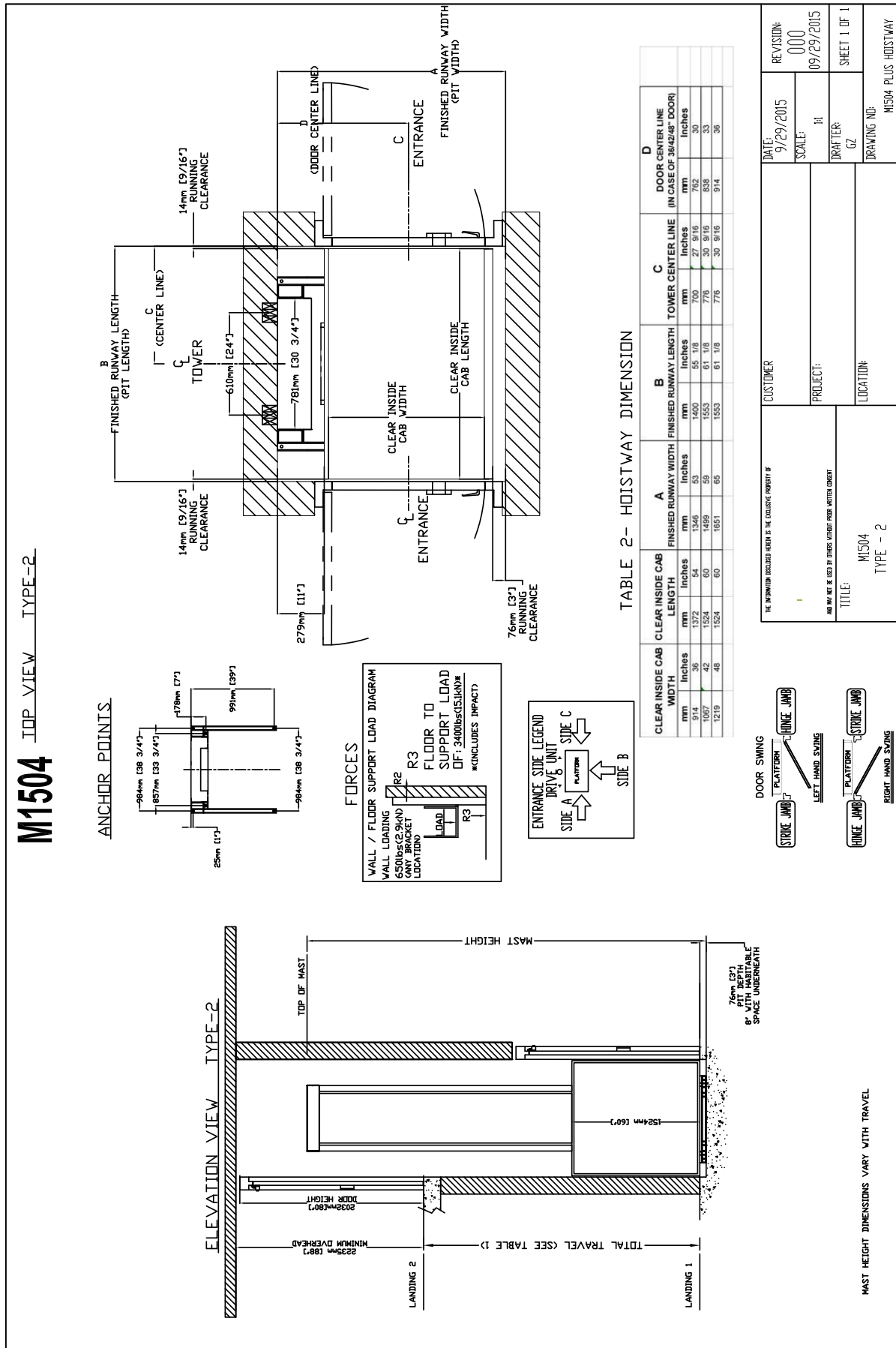

Figure 10: Auto door, left-hand

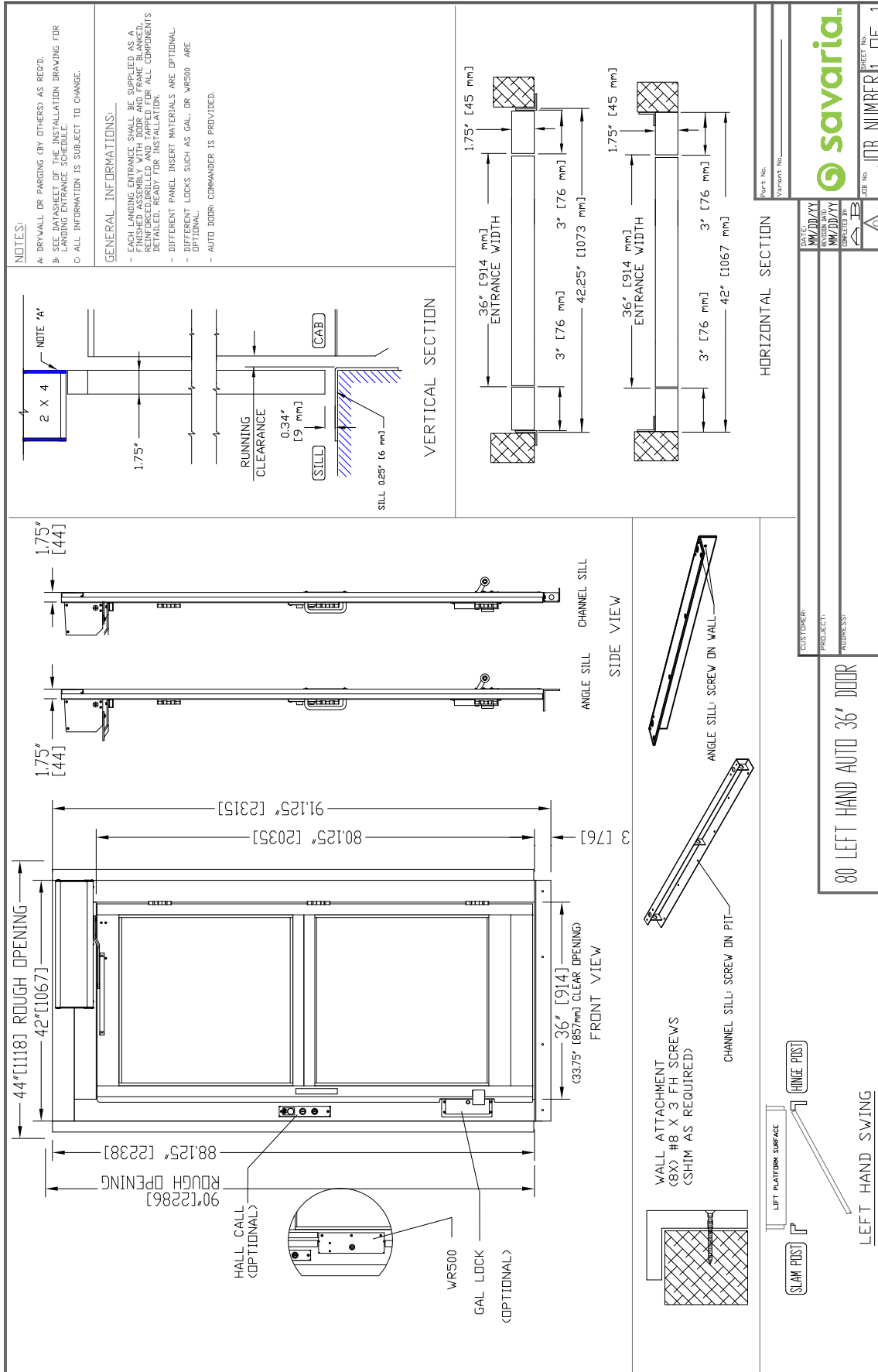

Figure 11: Auto door, right-hand

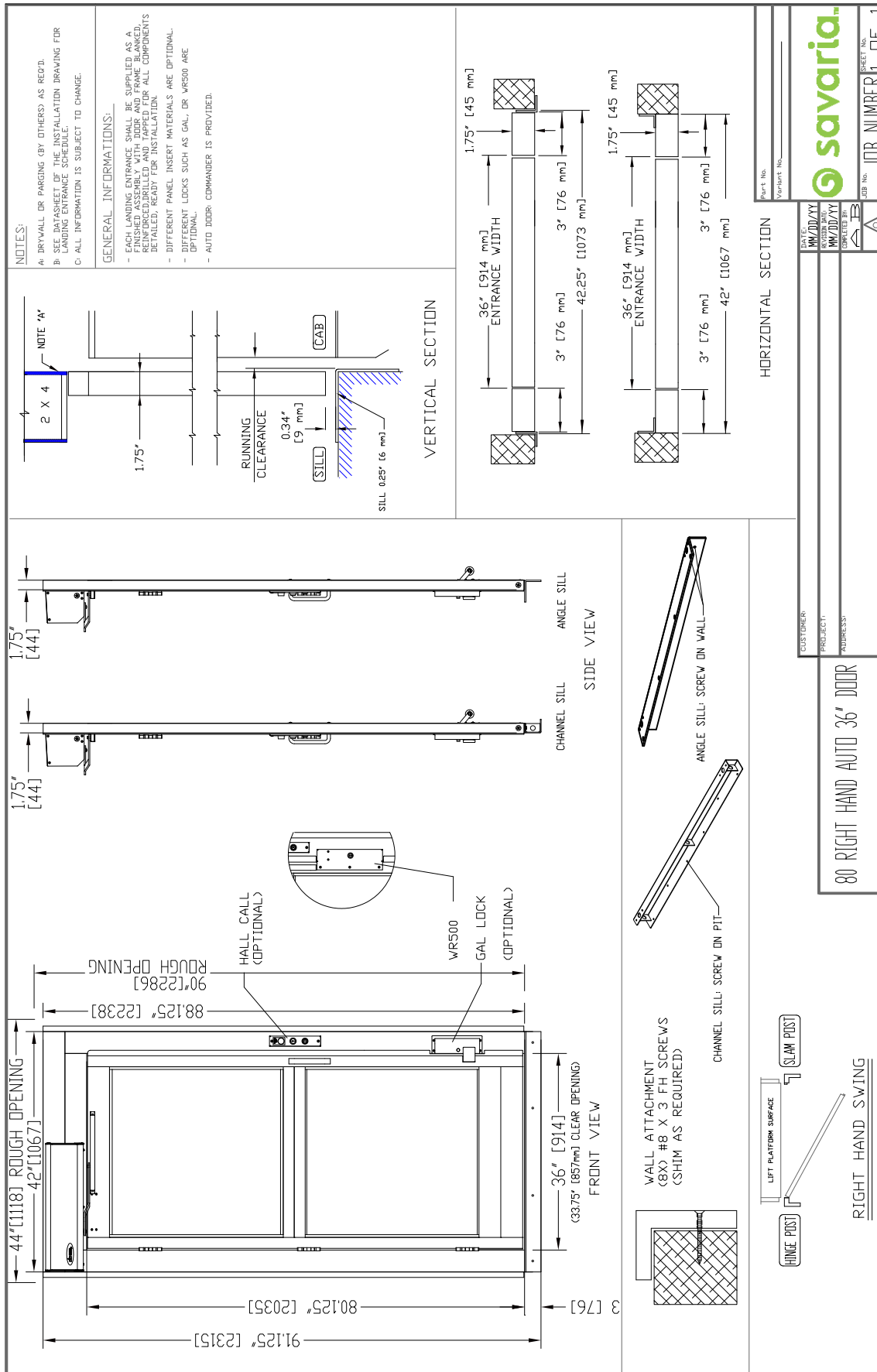

Figure 12: Manual door, left-hand

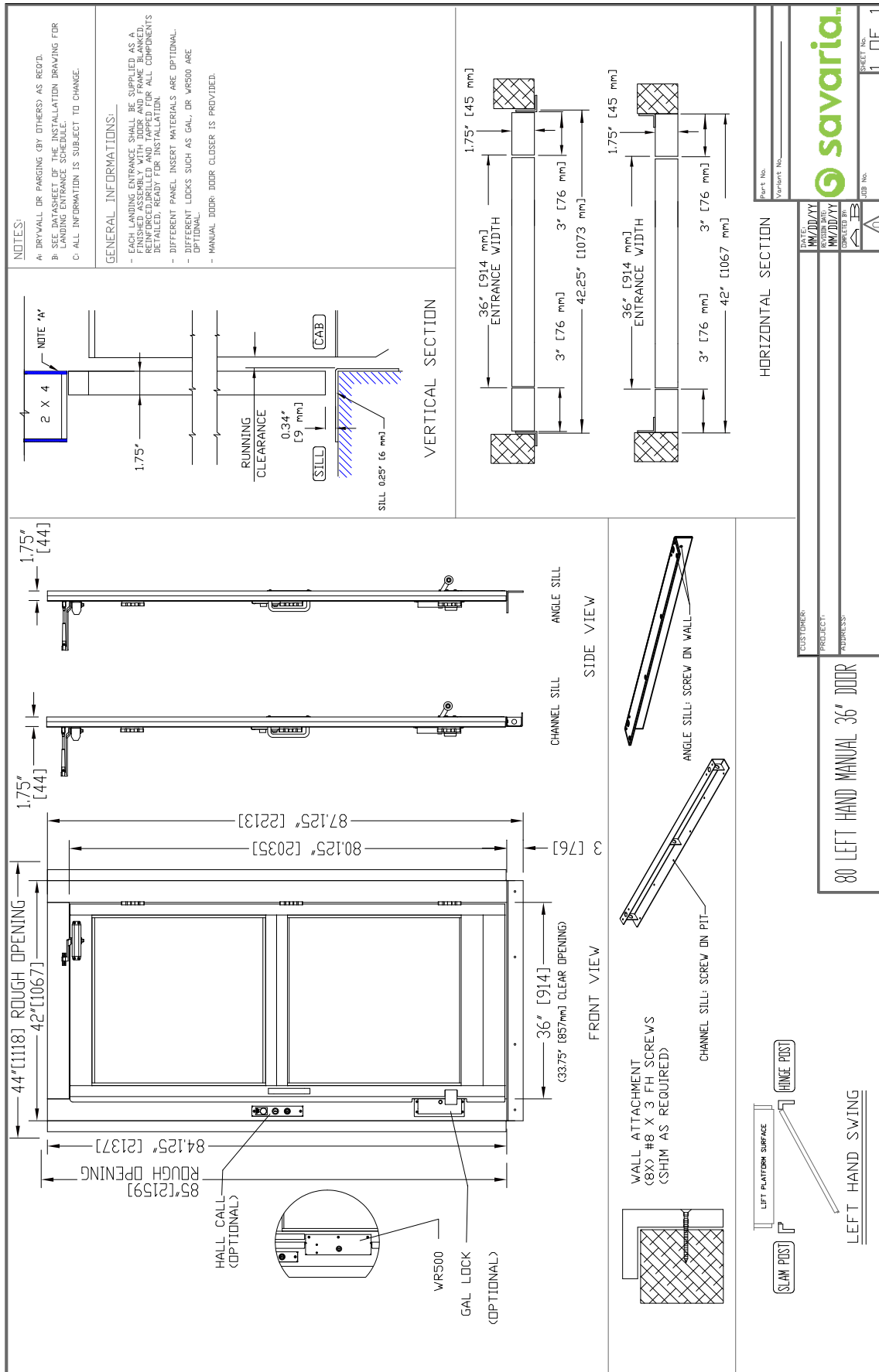

Figure 13: Manual door, right-hand

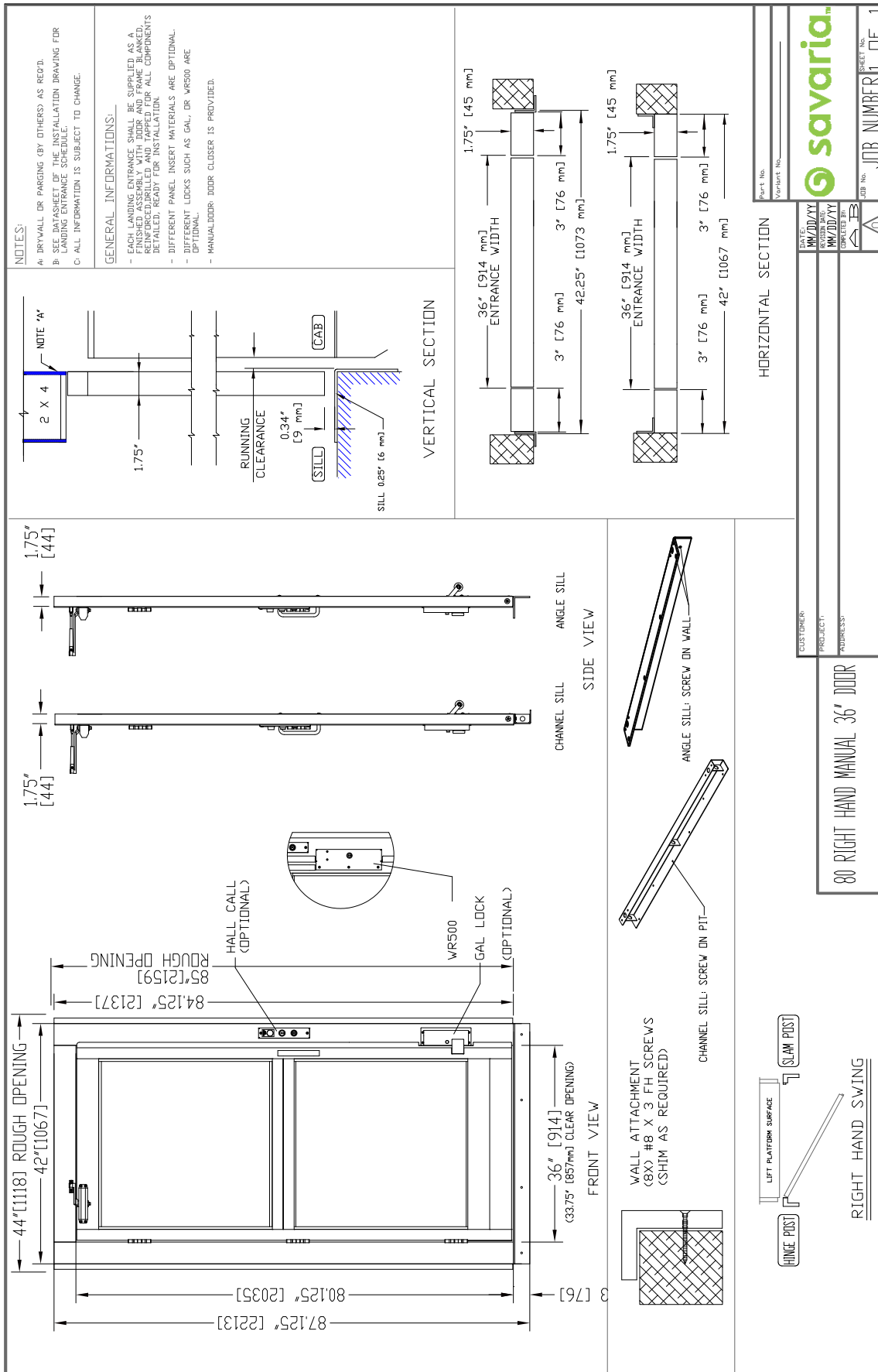

Figure 14: Prodoor auto, left-hand

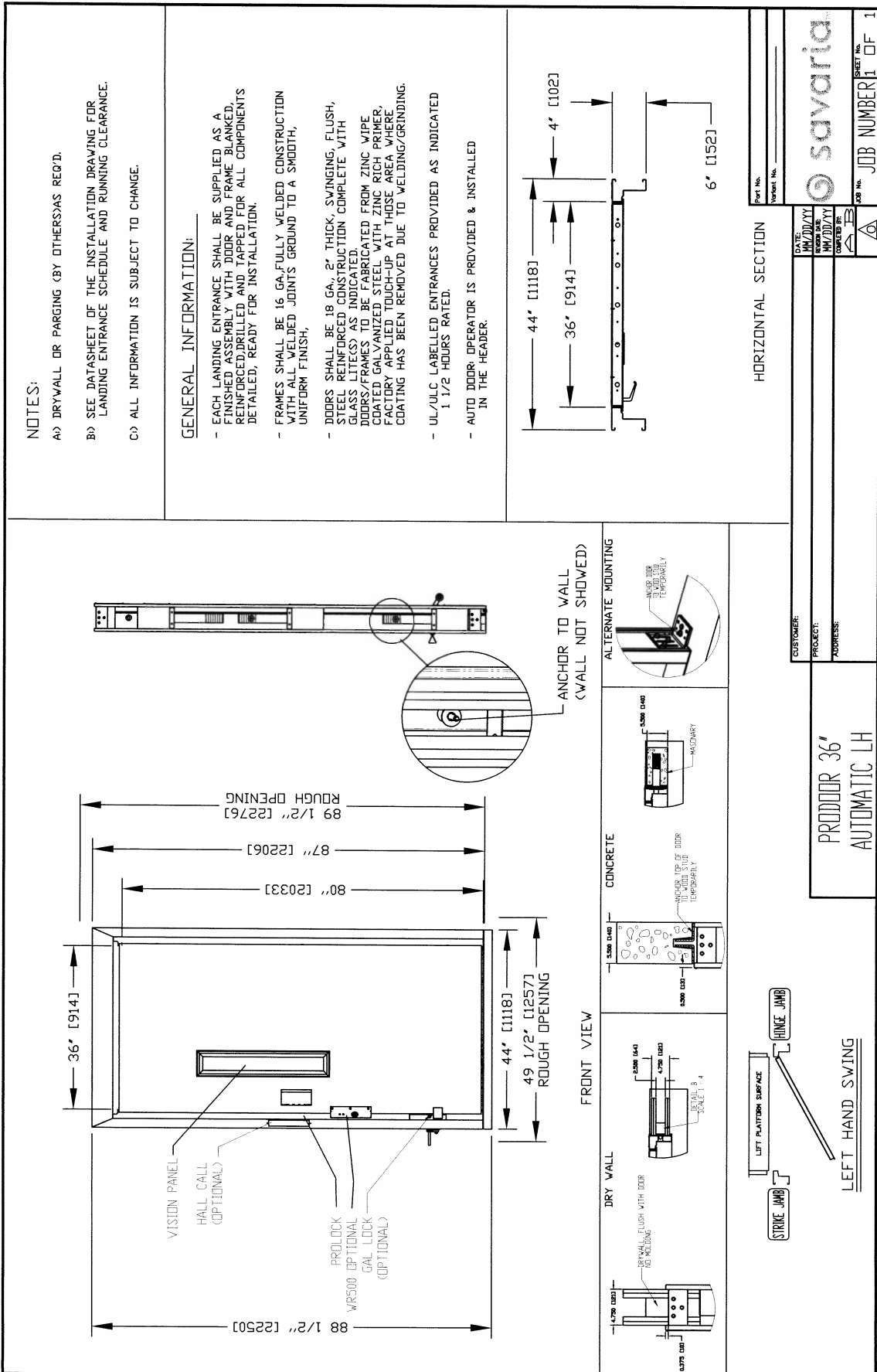

Figure 15: Prodoor auto, right-hand

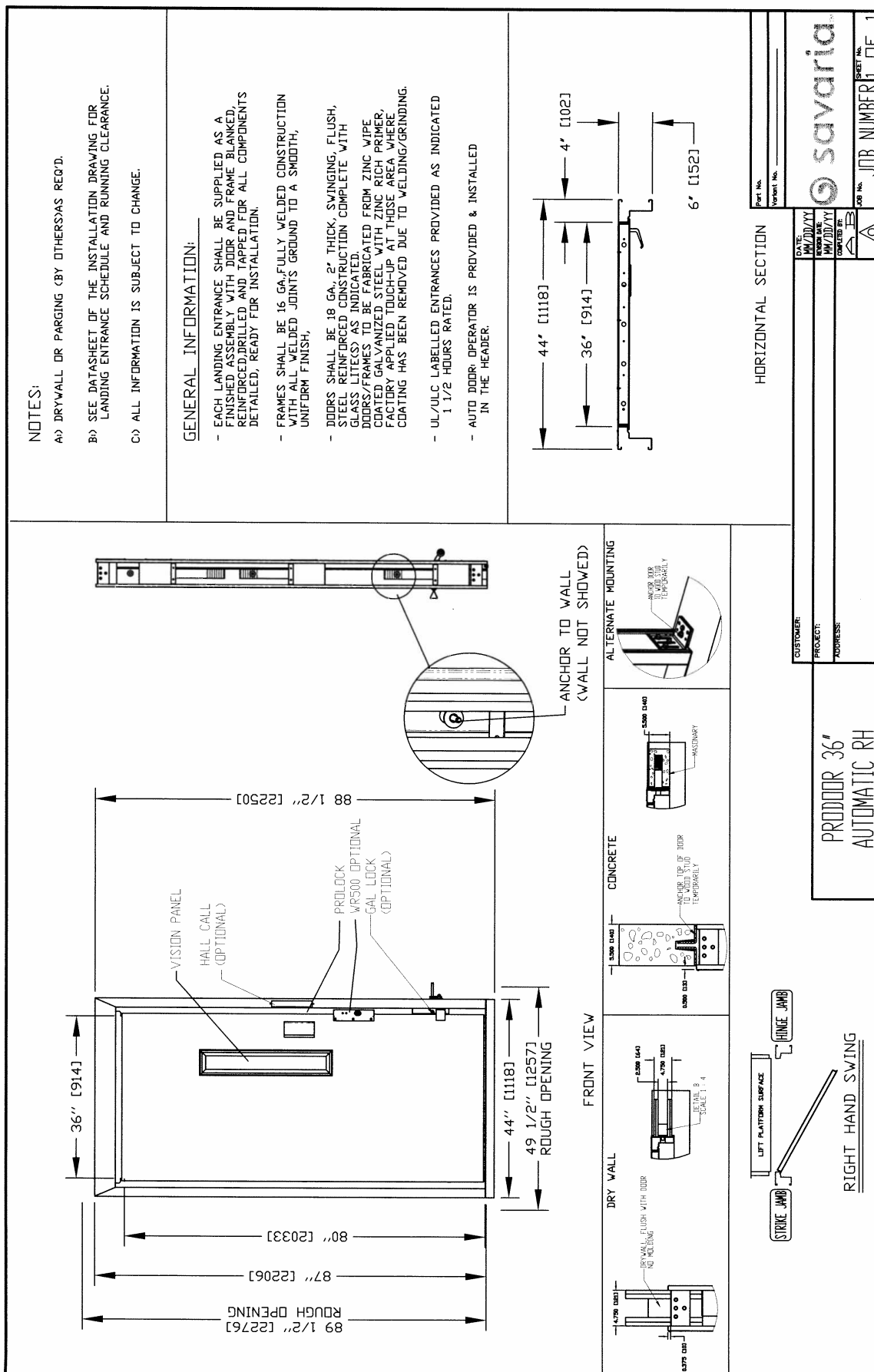

Figure 16: Prodoor manual, left-hand

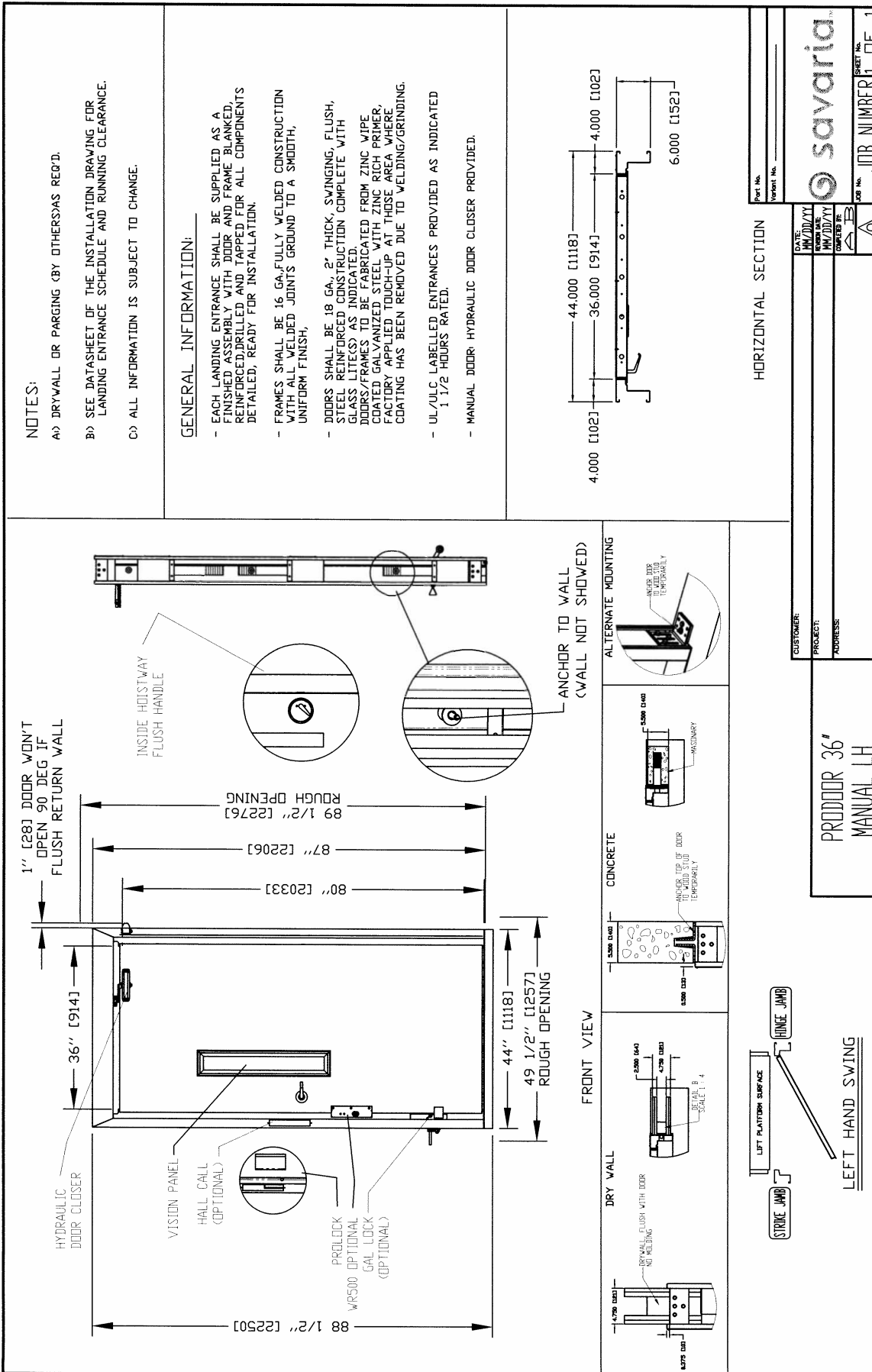

Figure 17: Prodoor manual, right-hand

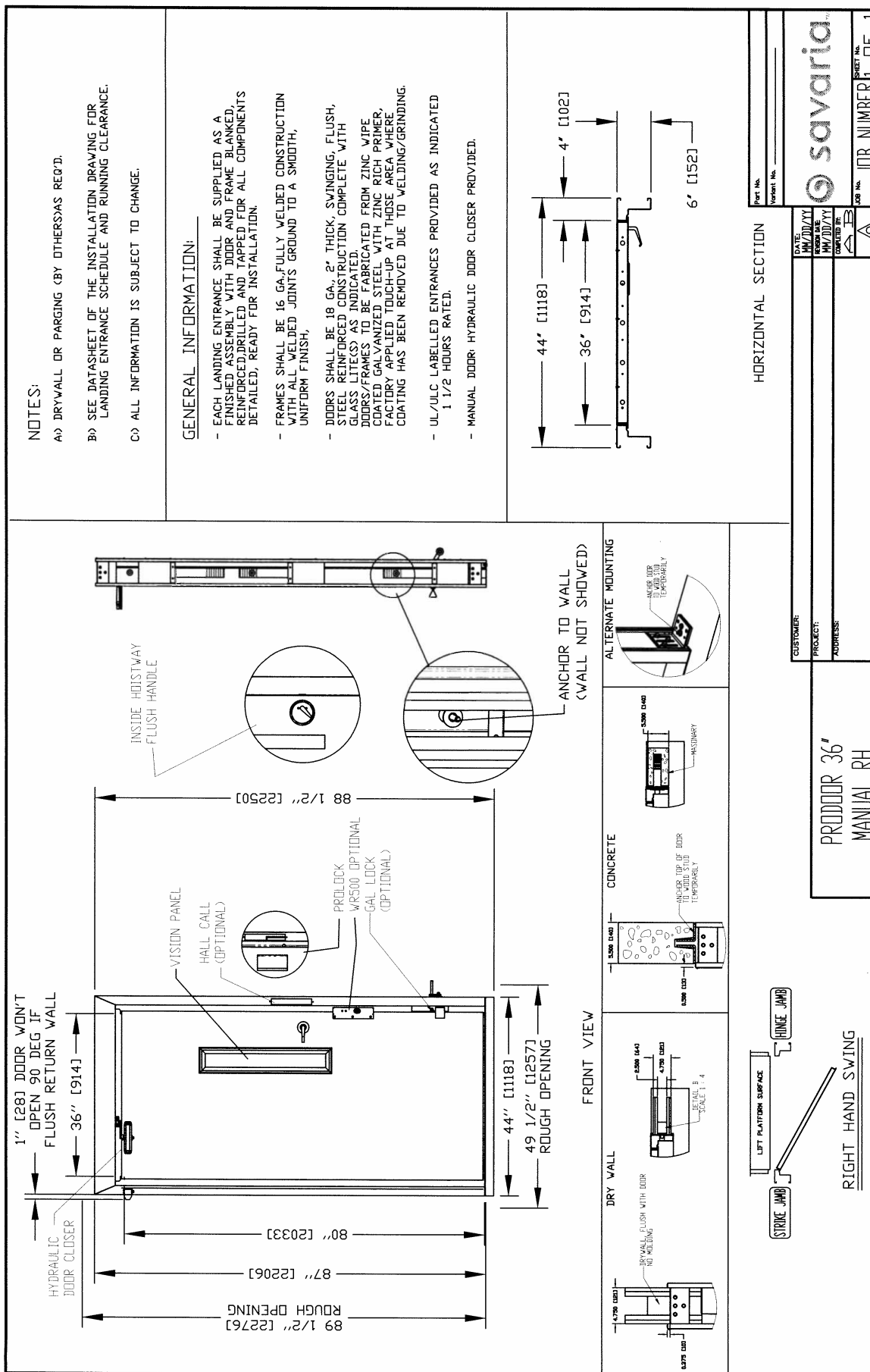
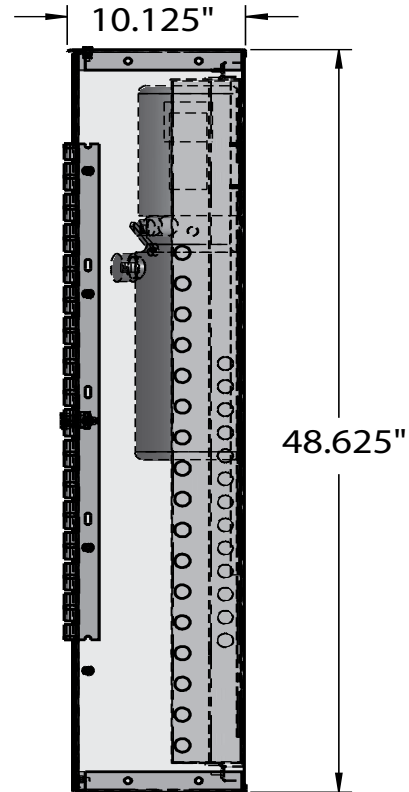
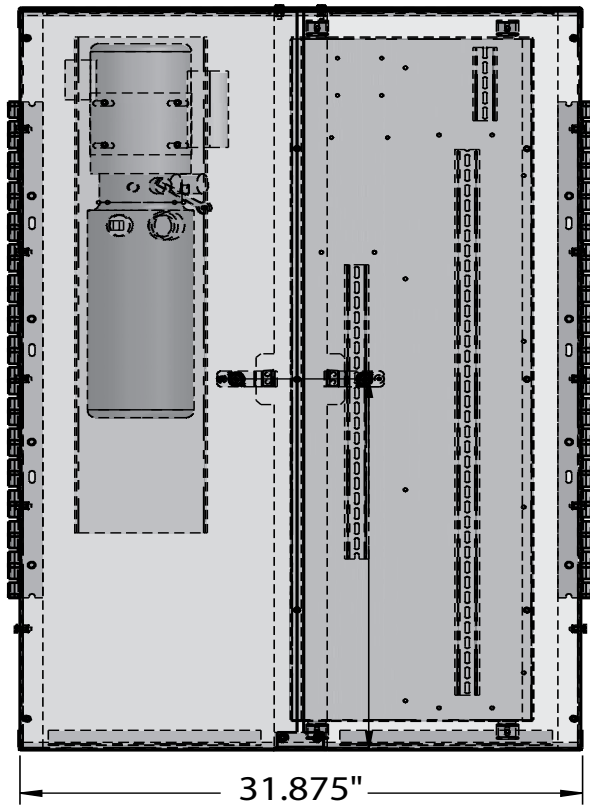
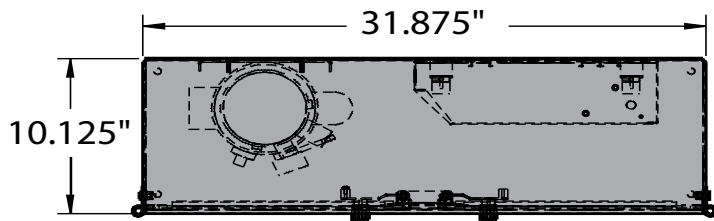

Figure 18: Remote controller/pump box dimensions



PROVISIONS BY OTHERS

GENERAL REQUIREMENTS

Hoistway

The hoistway must be designed and built in accordance with the “safety standard for platform lifts and stairway chairlifts” or the “safety code for elevators and escalators” and all state and local codes.

Plumb Runway

Due to close running clearances, the owner/agent must ensure that the hoistway and the pit (where provided) are level, plumb and square and are in accordance with the dimensions on the installation drawings.

Minimum Overhead Clearance

The owner/agent must ensure the minimum overhead clearance is in compliance with codes.

Construction Site

The owner/agent is required to provide all masonry, carpentry and drywall work as required and shall patch and make good (including finish painting) all areas where walls/floors may need to be cut, drilled or altered in any way to permit the proper installation of the lift.

Dimensions

The contractor/customer is required to verify all dimensions and report any discrepancies to our office immediately.

STRUCTURAL REQUIREMENTS

Floor/Support Wall Loads

The structural engineer is to ensure that the building and shaft will safely support all loads imposed by the lift equipment. Refer to the installation drawings for the loads imposed by the equipment.

Mast to be Securely Fastened

Where required, the mast must be securely fastened to the structural support wall. Refer to the installation drawings for the loads imposed by the equipment.

Where Doors are Required

Suitable lintels must be provided by the owner/agent. Door frames are not designed to support overhead wall loads.

ELECTRICAL REQUIREMENTS

General

Electrical equipment and wiring must comply with Section 38 of CSA C22.1 (Canada) or Section 620 of NEC ANSI NFPA 70 (USA).

Power Supply

A 120 VAC, 30A, 60 Hz, single-phase circuit through a fused disconnect with an auxiliary contact on the main power supply is required.

Lighting

Lighting of 100 lux minimum is required at platforms and landings. Lighting with a switch and electrical GFCI outlet is required in the hoistway pit.

ENTRANCE REQUIREMENTS

Upper Landing Gates

Where required, smooth solid barriers are to be supplied and installed on both sides of the entrance at the upper level and must be a minimum of 80” (2032 mm) high. The entrance assembly must be in place prior to this provision.

Fascia Panel Below Upper Level Entrance

Where required, fascia panel must be fastened to a solid wall and be perpendicular to the floor and walls. Hoistway fascia is not self-supporting for long, continuous runs void of entrances. Adequate support for the fascia must be provided.

Entrance Assemblies

Entrance assemblies must be adjusted to align with the platform and interlock equipment. Others must allow an adequate opening.

Return Walls

Return walls at the entrances must be built-in by others after the entrance assemblies are in place. The entrance assembly must be securely fastened to the walls by the contractor.

SAVARIA LINK OPTION

If you have the Savaria Link Ethernet remote monitoring option, ensure that you have an Ethernet connection with Internet capability in the vicinity of the unit’s controller.

If you have the Savaria Link Wireless remote monitoring option, ensure that you have a wireless signal with Internet capability in the vicinity of the unit’s controller.

Find more design resources at:

[savaria.com](https://www.savaria.com)

[CAD drawings](#)

[Owner's manual](#)

Savaria Concord Lifts, Inc.
2 Walker Drive Brampton ON L6T 5E1 Canada

 **savaria.**
savaria.com

©2022 Savaria Corporation