



Zenith  
Residential  
Elevator

Planning  
Guide

© savaria.

**Applicable Codes:**

ASME A17.1/CSA-B44

Safety Code for Elevators and Escalators

Section 5.3 – Private Residential Elevators

## IMPORTANT NOTICE

This Planning Guide provides nominal dimensions and specifications useful for the initial planning of a project. Before beginning actual construction, make sure you have the installation (shop) drawings customized with specifications and dimensions for your specific project.

NOTE: The cab dimensions provided in this manual are based on a PLAM cab.

Lift configurations and dimensions are in accordance with our interpretation of the standards set forth by the codes listed on the front cover of this Planning Guide. Please consult Savaria or the authorized Savaria dealer in your area for more specific information pertaining to your project, including any discrepancy between referenced standards and those of any local codes or laws.

The dimensions and specifications in this Planning Guide are subject to change (without notice) due to product enhancements and continually evolving codes and product applications.

Visit our website [www.savaria.com](http://www.savaria.com) for the most current drawings and dimensions.

## Purpose of This Guide

This Planning Guide is designed to assist architects, contractors, and elevator professionals in planning for the Zenith Residential Elevator to meet the requirements of the following codes and standards:

- ASME A17.1/CSA B44 2000, Section 5.3
- ASME A17.1/CSA B44 2004, Section 5.3
- ASME A17.1 2004, Addendum 2005, Section 5.3
- ASME A17.1/CSA B44 2007, Section 5.3
- ASME A17.1/CSA B44, Addendum 2008, Section 5.3
- ASME A17.1/CSA B44 2010, Section 5.3
- ASME A17.1/CSA B44 2013, Section 5.3
- ASME A17.1/CSA B44 2016, Section 5.3
- ASME A17.1/CSA B44 2019, Section 5.3
- ASME A17.1 1996, Part 5

We recommend that you contact your local authority having jurisdiction to ensure that you adhere to all local rules and regulations pertaining to residential elevators.

## How to Use This Guide

- 1 Determine your client's intended use of the elevator.
- 2 Determine the local code requirements.
- 3 Determine the site installation parameters.
- 4 Determine the cab type and hoistway size requirements.
- 5 Plan for electrical requirements.

## Revision History of This Guide

- September 9, 2019 – Initial release
- September 16, 2019 – Revised controller box dimensions on page 71
- September 18, 2019 – Revised daily cycle to 200 in specs table on page 6
- September 26, 2019 – Revised all drawings to latest version
- October 9, 2019 – Revised specifications table on page 7
- October 11, 2019 – Added rail support wall structure drawing on page 127
- December 3, 2019 – Revised drawing on page 126
- December 6, 2019 – Added optional load capacity and rated speed on page 7
- January 9, 2020 – Added note to temperature spec on page 7
- January 16, 2020 – Revised power spec on page 6, Added outdoor hall call as option on page 8; Revised power info on page 129
- March 2, 2020 – Reduced size of planning guide by showing two plan views per page; Revised to indicate powered battery lowering in specs table on page 8; Revised drawings on page 61 to 65; Removed NOTE that references a PLAM cab from all drawings
- March 3, 2020 – Revised noise level spec on page 7; Added 2 new drawings on page 37 (36 x 48 Type 5)
- March 11, 2020 – Revised noise level spec on page 7
- March 18, 2020 – Revised optional speed spec on page 7
- March 23, 2020 – Revised drawings on pages 9, 21 and 30
- May 1, 2020 – Added Note to Minimum Overhead spec on page 7 re: counterweight safety option; Added counterweight safeties to Options on page 8
- May 5, 2020 – Revised Distance Between Floors spec on page 7
- May 12, 2020 – Added new spec “floor by others (in cab)” to specs table on page 7
- June 24, 2020 – Added code for 2019 to code list above; Added manual lowering winch info to Electrical section of Provisions by others on page 75
- October 20, 2020 - Added flush wood door instructions on pages 76 through 79
- October 22, 2020 - Added heavy and excessive cycle values on page 7
- August 26, 2021 - Updated figure on page 74
- September 2, 2021 - Updated plan views
- August 02, 2022 - Updated cover
- August 11, 2023 - Revised graphic on pages 9-29

## Table of Contents

Specifications .....	7
<b>PANEL-FOLD DOORS .....</b>	<b>9</b>
Sample Elevation View, Panel-fold Doors .....	9
36" x 49.5" Type 3 Cab, Panel-fold Doors .....	10
36" x 49.5" Type 4 Cab, Panel-fold Doors .....	10
36" x 48" Type 5 Cab, Panel-fold Doors .....	11
36" x 48" Type 5-7 Cab, Panel-fold Doors .....	11
36" x 48" Type 5-8 Cab, Panel-fold Doors .....	12
36" x 54" Type 1L Cab, Panel-fold Doors .....	12
36" x 54" Type 1R Cab, Panel-fold Doors .....	13
36" x 54" Type 2 Cab, Panel-fold Doors .....	13
36" x 54" Type 3 Cab, Panel-fold Doors .....	14
36" x 54" Type 4 Cab, Panel-fold Doors .....	14
36" x 60" Type 1L Cab, Panel-fold Doors .....	15
36" x 60" Type 1R Cab, Panel-fold Doors .....	15
36" x 60" Type 2 Cab, Panel-fold Doors .....	16
36" x 60" Type 3 Cab, Panel-fold Doors .....	16
36" x 60" Type 4 Cab, Panel-fold Doors .....	17
36" x 60" Type 5-3 Cab, Panel-fold Doors .....	17
36" x 60" Type 5-4 Cab, Panel-fold Doors .....	18
40" x 54" Type 1L Cab, Panel-fold Doors .....	18
40" x 54" Type 1R Cab, Panel-fold Doors .....	19
40" x 54" Type 2 Cab, Panel-fold Doors .....	19
40" x 54" Type 3 Cab, Panel-fold Doors .....	20
40" x 54" Type 4 Cab, Panel-fold Doors .....	20
<b>BI-FOLD DOORS .....</b>	<b>21</b>
Sample Elevation View, Bi-fold Doors .....	21
36" x 48" Type 1L Cab, Bi-fold Doors .....	22
36" x 48" Type 1R Cab, Bi-fold Doors .....	22
36" x 48" Type 2 Cab, Bi-fold Doors .....	23
36" x 54" Type 1L Cab, Bi-fold Doors .....	23
36" x 54" Type 1R Cab, Bi-fold Doors .....	24
36" x 54" Type 2 Cab, Bi-fold Doors .....	24
36" x 60" Type 1L Cab, Bi-fold Doors .....	25
36" x 60" Type 1R Cab, Bi-fold Doors .....	25
36" x 60" Type 2 Cab, Bi-fold Doors .....	26
40" x 48" Type 1L Cab, Bi-fold Doors .....	26
40" x 48" Type 1R Cab, Bi-fold Doors .....	27
40" x 48" Type 2 Cab, Bi-fold Doors .....	27
40" x 54" Type 1L Cab, Bi-fold Doors .....	28
40" x 54" Type 1R Cab, Bi-fold Doors .....	28
40" x 54" Type 2 Cab, Bi-fold Doors .....	29

<b>AUTO SLIM DOORS .....</b>	<b>30</b>
Sample Elevation View, Auto Slim Doors .....	30
36" x 48" Type 1L Cab, Auto Slim (35.5") Doors .....	31
36" x 48" Type 1L Cab, Auto Slim (35.5") Doors + Swing .....	31
36" x 48" Type 1L Cab, Auto Slim (29.5") Doors .....	32
36" x 48" Type 1L Cab, Auto Slim (29.5") Doors + Swing .....	32
36" x 48" Type 1R Cab, Auto Slim (35.5") Doors .....	33
36" x 48" Type 1R Cab, Auto Slim (35.5") Doors + Swing .....	33
36" x 48" Type 1R Cab, Auto Slim (29.5") Doors .....	34
36" x 48" Type 1R Cab, Auto Slim (29.5") Doors + Swing .....	34
36" x 48" Type 2 Cab, Auto Slim (35.5") Doors .....	35
36" x 48" Type 2 Cab, Auto Slim (35.5") Doors + Swing .....	35
36" x 48" Type 2 Cab, Auto Slim (29.5") Doors .....	36
36" x 48" Type 2 Cab, Auto Slim (29.5") Doors + Swing .....	36
36" x 48" Type 5 Cab, Auto Slim (29.5") Doors .....	37
36" x 48" Type 5 Cab, Auto Slim (29.5") Doors + Swing .....	37
36" x 54" Type 1L Cab, Auto Slim (35.5") Doors .....	38
36" x 54" Type 1L Cab, Auto Slim (35.5") Doors + Swing .....	38
36" x 54" Type 1L Cab, Auto Slim (29.5") Doors .....	39
36" x 54" Type 1L Cab, Auto Slim (29.5") Doors + Swing .....	39
36" x 54" Type 1R Cab, Auto Slim (35.5") Doors .....	40
36" x 54" Type 1R Cab, Auto Slim (35.5") Doors + Swing .....	40
36" x 54" Type 1R Cab, Auto Slim (29.5") Doors .....	41
36" x 54" Type 1R Cab, Auto Slim (29.5") Doors + Swing .....	41
36" x 54" Type 2 Cab, Auto Slim (35.5") Doors .....	42
36" x 54" Type 2 Cab, Auto Slim (35.5") Doors + Swing .....	42
36" x 54" Type 2 Cab, Auto Slim (29.5") Doors .....	43
36" x 54" Type 2 Cab, Auto Slim (29.5") Doors + Swing .....	43
36" x 54" Type 3 Cab, Auto Slim (35.5") Doors .....	44
36" x 54" Type 3 Cab, Auto Slim (35.5") Doors + Swing .....	44
36" x 54" Type 3 Cab, Auto Slim (29.5") Doors .....	45
36" x 54" Type 3 Cab, Auto Slim (29.5") Doors + Swing .....	45
36" x 54" Type 4 Cab, Auto Slim (35.5") Doors .....	46
36" x 54" Type 4 Cab, Auto Slim (35.5") Doors + Swing .....	46
36" x 54" Type 4 Cab, Auto Slim (29.5") Doors .....	47
36" x 54" Type 4 Cab, Auto Slim (29.5") Doors + Swing .....	47
36" x 54" Type 5 Cab, Auto Slim (35.5") Doors .....	48
36" x 54" Type 5 Cab, Auto Slim (35.5") Doors + Swing .....	48
36" x 54" Type 5 Cab, Auto Slim (29.5") Doors .....	49
36" x 54" Type 5 Cab, Auto Slim (29.5") Doors + Swing .....	49
36" x 60" Type 1L Cab, Auto Slim (35.5") Doors .....	50
36" x 60" Type 1L Cab, Auto Slim (35.5") Doors + Swing .....	50
36" x 60" Type 1L Cab, Auto Slim (29.5") Doors .....	51
36" x 60" Type 1L Cab, Auto Slim (29.5") Doors + Swing .....	51
36" x 60" Type 1R Cab, Auto Slim (35.5") Doors .....	52
36" x 60" Type 1R Cab, Auto Slim (35.5") Doors + Swing .....	52

36" x 60" Type 1R Cab, Auto Slim (29.5") Doors .....	53
36" x 60" Type 1R Cab, Auto Slim (29.5") Doors + Swing .....	53
36" x 60" Type 2 Cab, Auto Slim (35.5") Doors .....	54
36" x 60" Type 2 Cab, Auto Slim (35.5") Doors + Swing .....	54
36" x 60" Type 2 Cab, Auto Slim (29.5") Doors .....	55
36" x 60" Type 2 Cab, Auto Slim (29.5") Doors + Swing .....	55
36" x 60" Type 3 Cab, Auto Slim (35.5") Doors .....	56
36" x 60" Type 3 Cab, Auto Slim (35.5") Doors + Swing .....	56
36" x 60" Type 3 Cab, Auto Slim (29.5") Doors .....	57
36" x 60" Type 3 Cab, Auto Slim (29.5") Doors + Swing .....	57
36" x 60" Type 4 Cab, Auto Slim (35.5") Doors .....	58
36" x 60" Type 4 Cab, Auto Slim (35.5") Doors + Swing .....	58
36" x 60" Type 4 Cab, Auto Slim (29.5") Doors .....	59
36" x 60" Type 4 Cab, Auto Slim (29.5") Doors + Swing .....	59
36" x 60" Type 5 Cab, Auto Slim (35.5") Doors .....	60
36" x 60" Type 5 Cab, Auto Slim (35.5") Doors + Swing .....	60
36" x 60" Type 5 Cab, Auto Slim (29.5") Doors .....	61
36" x 60" Type 5 Cab, Auto Slim (29.5") Doors + Swing .....	61
40" x 48" Type 1L Cab, Auto Slim (35.5") Doors .....	62
40" x 48" Type 1R Cab, Auto Slim (35.5") Doors .....	62
40" x 48" Type 2 Cab, Auto Slim (35.5") Doors .....	63
40" x 54" Type 1L Cab, Auto Slim (35.5") Doors .....	63
40" x 54" Type 1L Cab, Auto Slim (35.5") Doors + Swing .....	64
40" x 54" Type 1R Cab, Auto Slim (35.5") Doors .....	64
40" x 54" Type 1R Cab, Auto Slim (35.5") Doors + Swing .....	65
40" x 54" Type 2 Cab, Auto Slim (35.5") Doors .....	65
40" x 54" Type 2 Cab, Auto Slim (35.5") Doors + Swing .....	66
40" x 54" Type 3 Cab, Auto Slim (35.5") Doors .....	66
40" x 54" Type 3 Cab, Auto Slim (35.5") Doors + Swing .....	67
40" x 54" Type 4 Cab, Auto Slim (35.5") Doors .....	67
40" x 54" Type 4 Cab, Auto Slim (35.5") Doors + Swing .....	68
40" x 54" Type 5 Cab, Auto Slim (35.5") Doors .....	68
40" x 54" Type 5 Cab, Auto Slim (35.5") Doors + Swing .....	69
Auto slim doors entrance assembly, CO = 2100 .....	70
Hoistway and Pit Notes .....	71
Loads on Building and Pit Loading .....	72
Rail Support Wall Structure .....	73
Controller Box Dimensions .....	74
Provisions By Others .....	74

## Specifications

Specification type	Specification data
Load capacity	1400 lb (635 kg) if 40 ft/min (standard) 1000 lb (454 Kg) if 60 ft/min (optional)
Rated speed	40 ft/min (0.20 m/sec) - standard 50 ft/min (0.25 m/sec) - optional
Power supply (circuit by others)	240 Volt, single-phase, 40 Amps, 60 Hz
Lighting supply (circuit by others)	120 Volt, 15 Amps, 60 Hz
Drive system	Counterweight traction with slack cable safety device Geared motor 1:1 sheave Three 3/8" diameter steel cables (ropes) Rope wedge sockets
Cab size	<ul style="list-style-type: none"> <li>• 36" x 48" (914 mm x 1219 mm)</li> <li>• 36" x 54" (914 mm x 1372 mm)</li> <li>• 36" x 60" (914 mm x 1524 mm)</li> <li>• 40" x 54" (1016 mm x 1372 mm)</li> </ul>
Floor by others (in cab)	3/4" (19 mm) maximum
Cab panel finish	Solid melamine or MDF panels (standard), unfinished oak veneer panels (optional), finished recessed veneer panels (optional), solid hardwood raised panels (optional)
Maximum travel	50 feet (12.24 m) - 60 feet (18.29 m) available where code permits
Control system	Micro-6 controller
Temperature operating range (environment)	- 10°C to + 40°C / 14°F to 104°F <b>NOTE:</b> For optimal running conditions, each landing of the unit should be in a climate-controlled environment.
Heat generated by motor	~ 2550 BTU/hr
Distance between floors	7" (178 mm) minimum (floors 1 to 2, 3 to 4, 5 to 6) 11" (279 mm) minimum (floors 2 to 3, 4 to 5)
Noise level (typical installation)	56 dBA (up and down directions) Measured 1m in front of the motor (no hoistway) with 600 lb (272 kg) in the cab
Daily cycle	Normal: 200 Heavy: 300 Excessive: 450 Maximum starts in 1 hour on standard installation: 45 <b>NOTE:</b> Consult your Sales Representative if there's a chance you may exceed these amounts.
Levels serviced	Up to 6 stops
Pit depth required	10" (254 mm) minimum
Minimum overhead clearance	108" (2743 mm) minimum <b>NOTE:</b> If there is habitable space below the hoistway, code requires you to install the Counterweight Safety Option. With the Counterweight Safety Option installed, the minimum overhead becomes 112.5" (2858 mm) or an additional 4.5" (114 mm) of pit depth is required.
Hall station and control panel finish	Clear or bronze anodized aluminum (standard), or stainless steel (optional), or brass (optional), or architect white (optional) Rectangular (standard) or oval (optional) hall stations, keyless (standard) or keyed (optional)

## Specifications

Specification type	Specification data
Standard features	Double 8 lb/ft T-rail modular system Anti-creep device Oxford white melamine ceiling Automatic cab ON/OFF lighting Car top stop switch Data plates, capacity tags and rope tags Digital floor and directional indicator Stop key switch and alarm buttons Emergency battery back-up for lighting, alarm and emergency lowering Powered emergency lowering Illuminated cab operating buttons Magnetic floor selection, stopping and re-leveling Slack rope safety switch (manual reset) Car top safety rail (for maintenance) Pit switch (emergency stop) 4 standard pot lights Recessed plywood floor Upper and lower terminal limits Overspeed governor Panel-fold doors
Options	Custom cab size 96" (2438 mm) high cab; 84" (2133 mm) high cab Rated speed - (50 fpm (0.250 mps) available where code permits) Accordion car gate (choice of style) Automatic gate operator Bi-fold doors Automatic slim doors Automatic swing landing door operator Buffer springs (11" pit depth minimum) Interlocks for doors by others and Savaria landing doors (fire rated door or wood door) Keyed on/off control panel and hall stations Optional cab finishes: raised hardwood, unfinished veneer Optional fixture finishes: brass #4 finish or blackened stainless steel (handrail, cab operating panel, hall call stations); hall call stations available in rectangular or oval Telephone cabinet to match trim Digital position indicator (PI) in hall calls Surface mount hall call for outdoor use Counterweight safeties



# Sample Elevation View, Panel-fold Doors

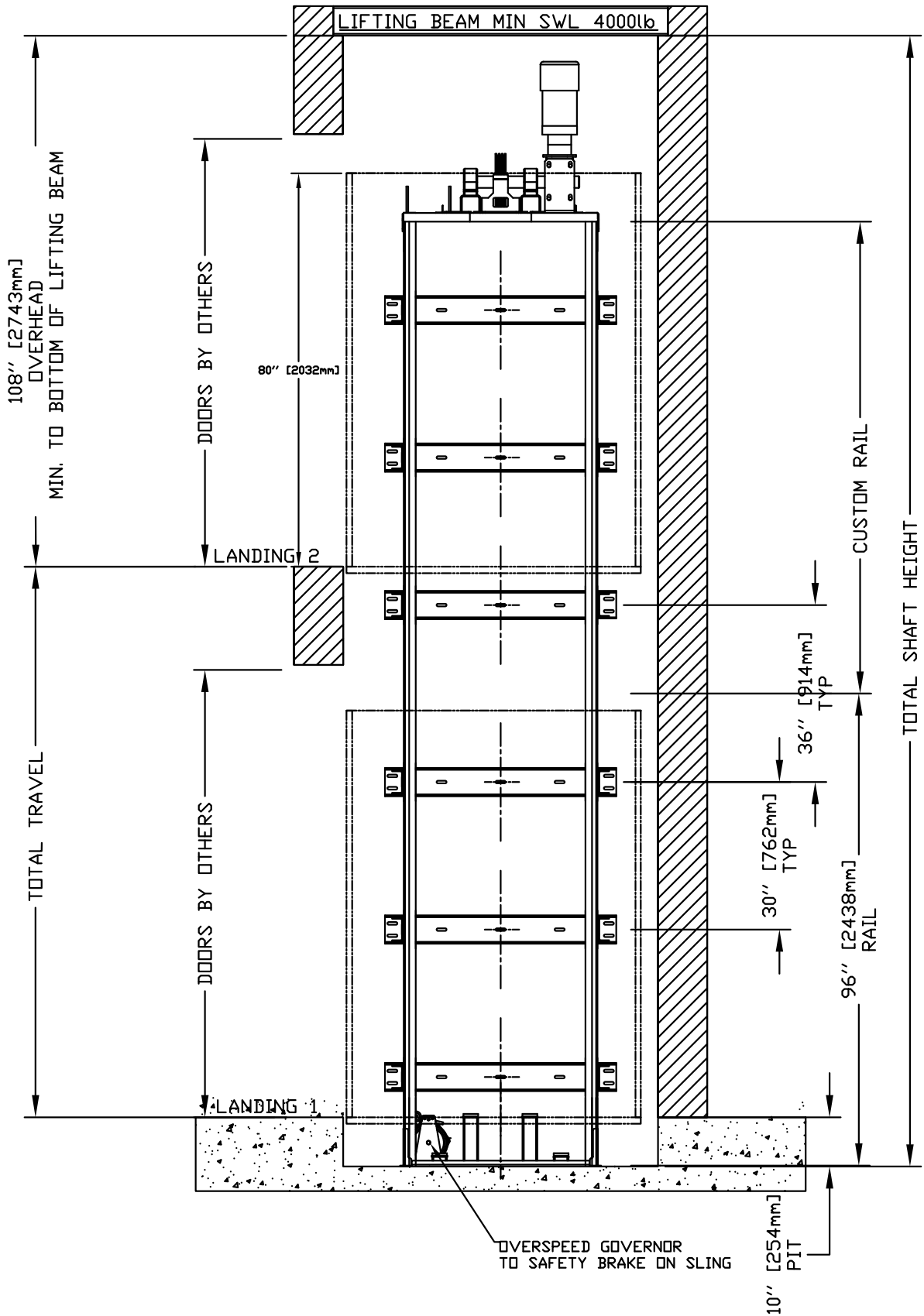

### 36" x 49.5" Type 3 Cab, Panel-fold Doors

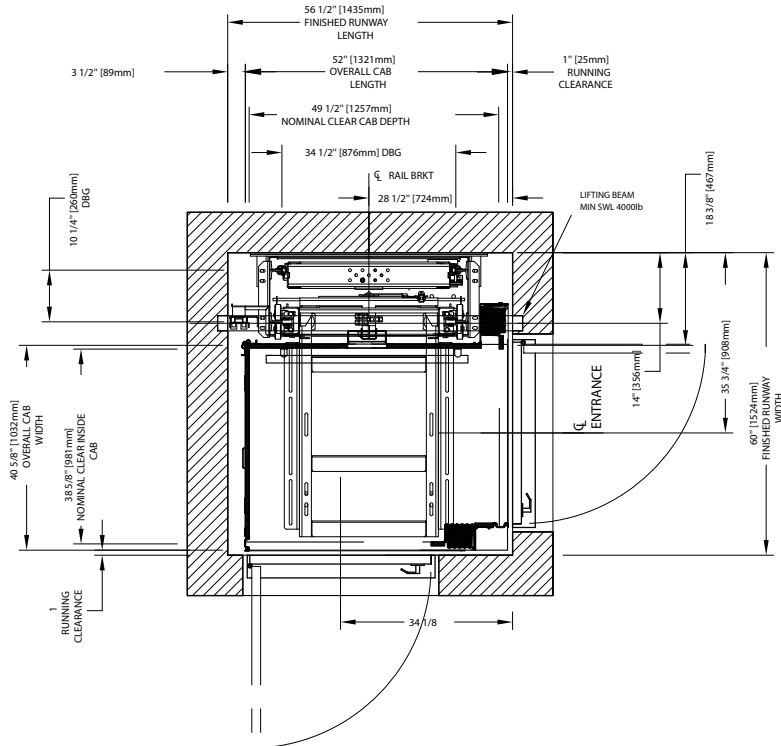

### 36" x 49.5" Type 4 Cab, Panel-fold Doors

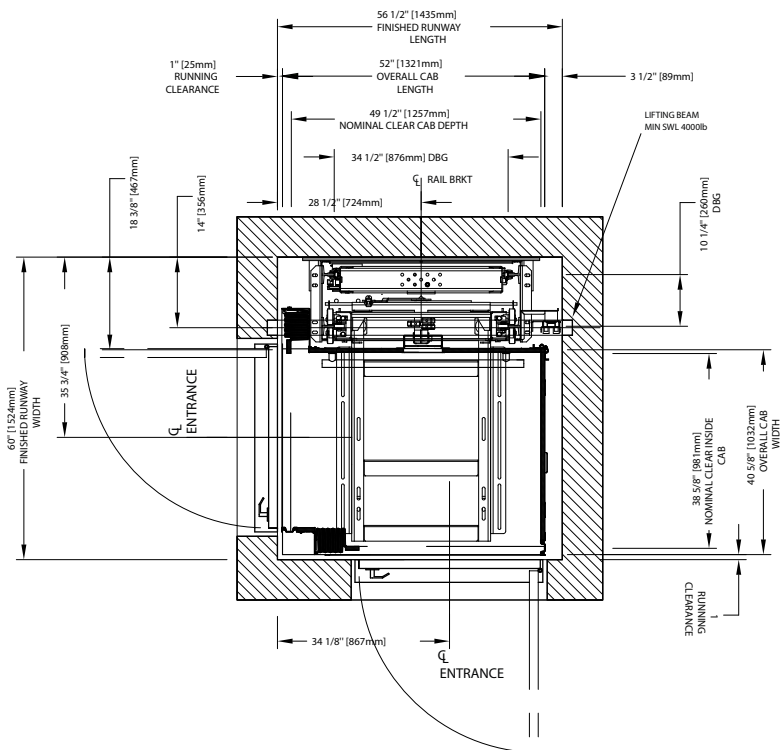

**IMPORTANT**

Finished hoistway dimensions must include the drywall. Determine the fire rating of the hoistway and the type and layers of sheet rock. Build only from the final shop drawings specific to your installation.

### 36" x 48" Type 5 Cab, Panel-fold Doors

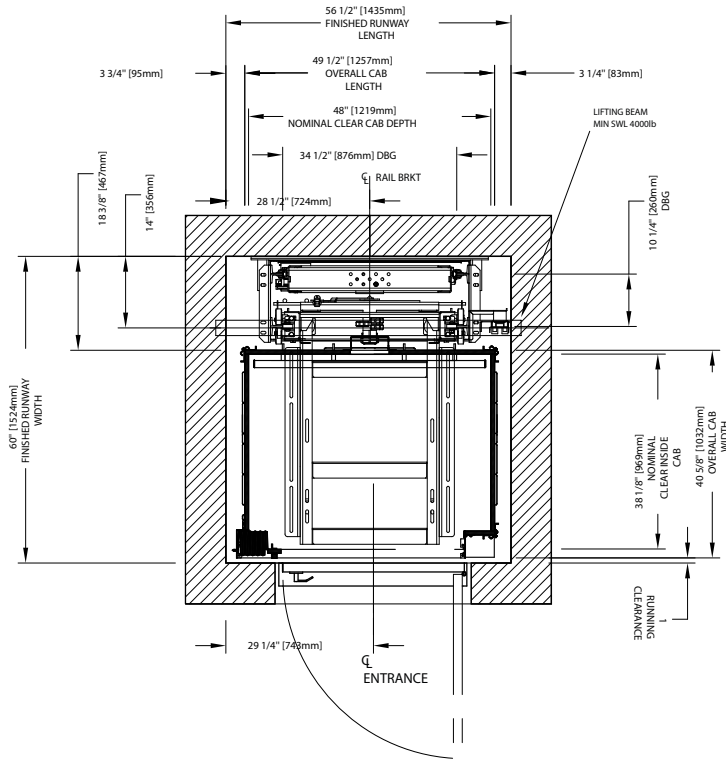

### 36" x 48" Type 5-7 Cab, Panel-fold Doors

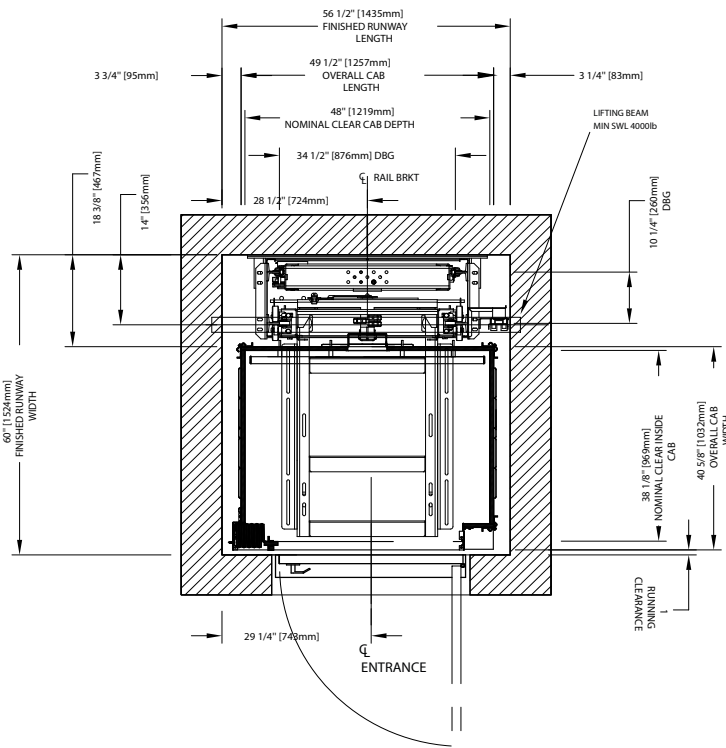

**IMPORTANT**

Finished hoistway dimensions must include the drywall. Determine the fire rating of the hoistway and the type and layers of sheet rock. Build only from the final shop drawings specific to your installation.

### 36" x 48" Type 5-8 Cab, Panel-fold Doors

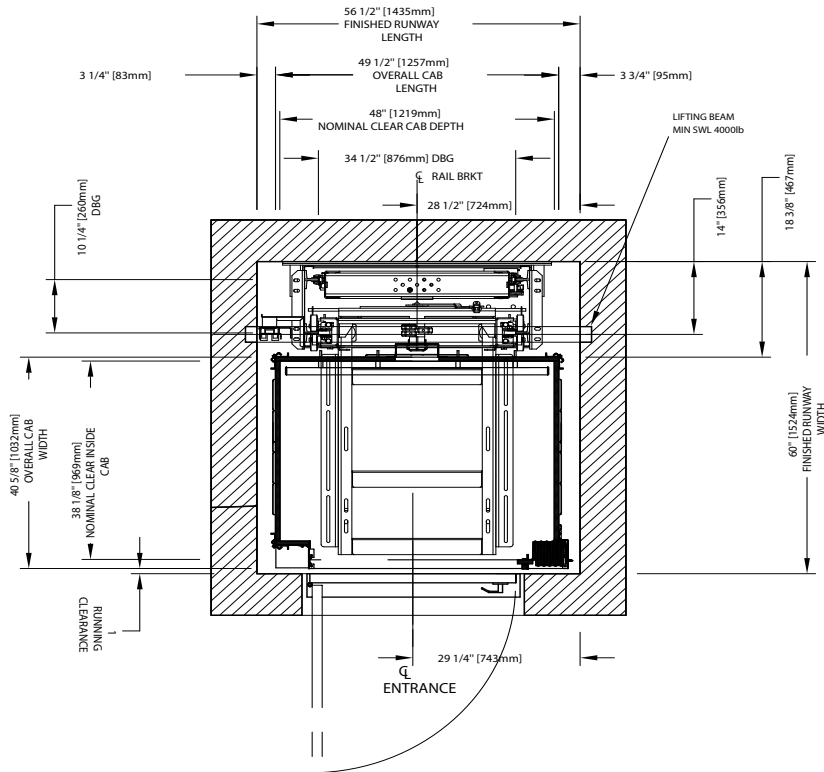

### 36" x 54" Type 1L Cab, Panel-fold Doors

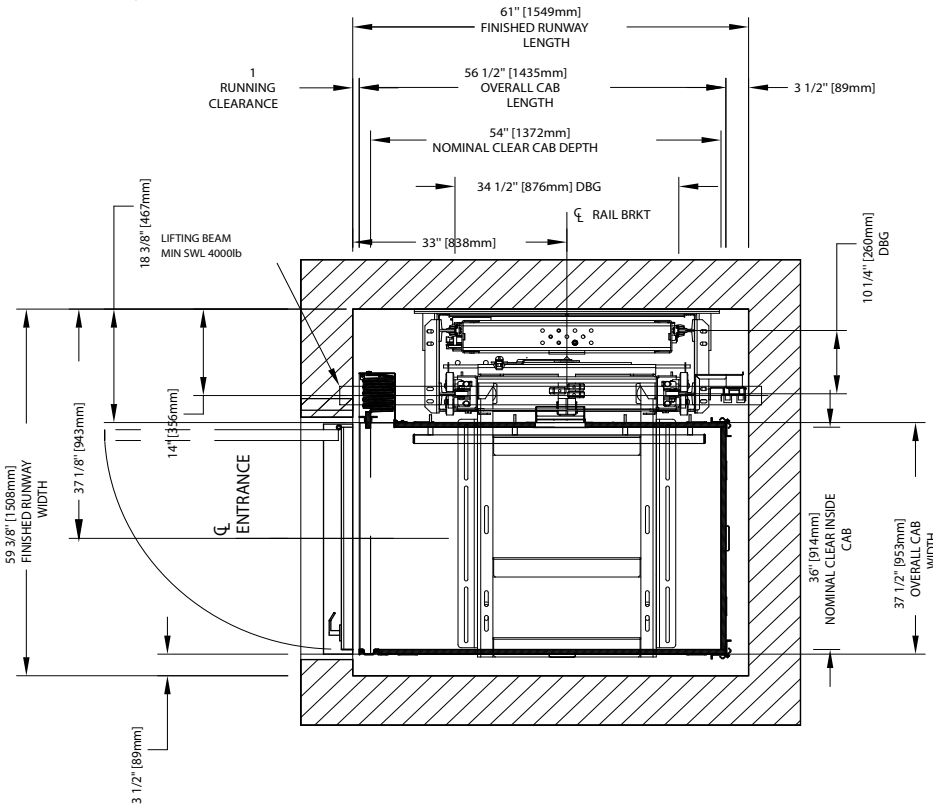

**IMPORTANT**

Finished hoistway dimensions must include the drywall. Determine the fire rating of the hoistway and the type and layers of sheet rock. Build only from the final shop drawings specific to your installation.

### 36" x 54" Type 1R Cab, Panel-fold Doors

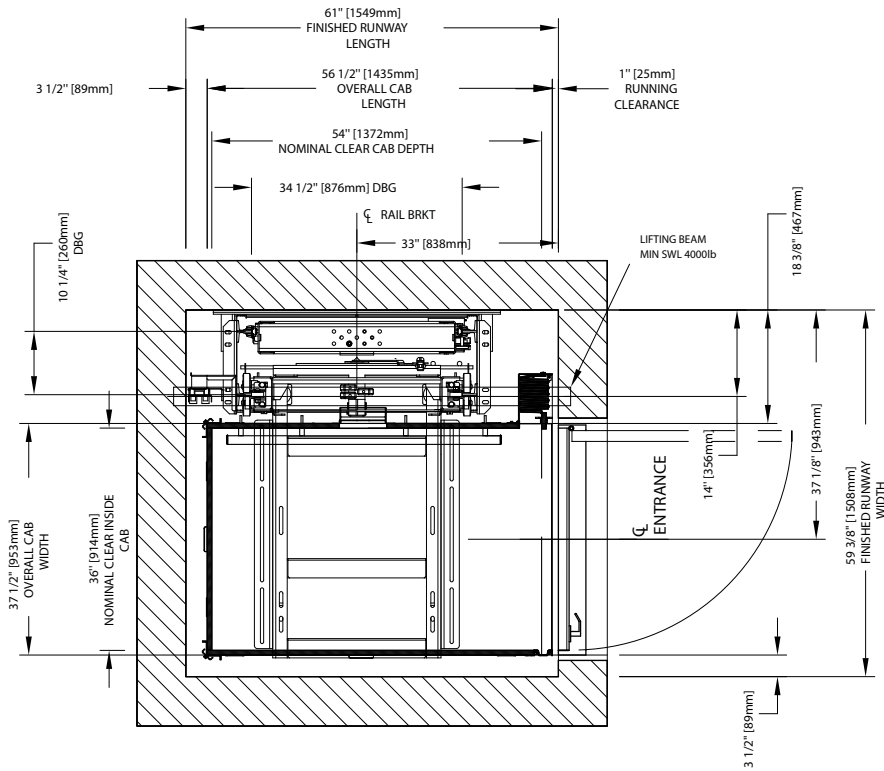

### 36" x 54" Type 2 Cab, Panel-fold Doors

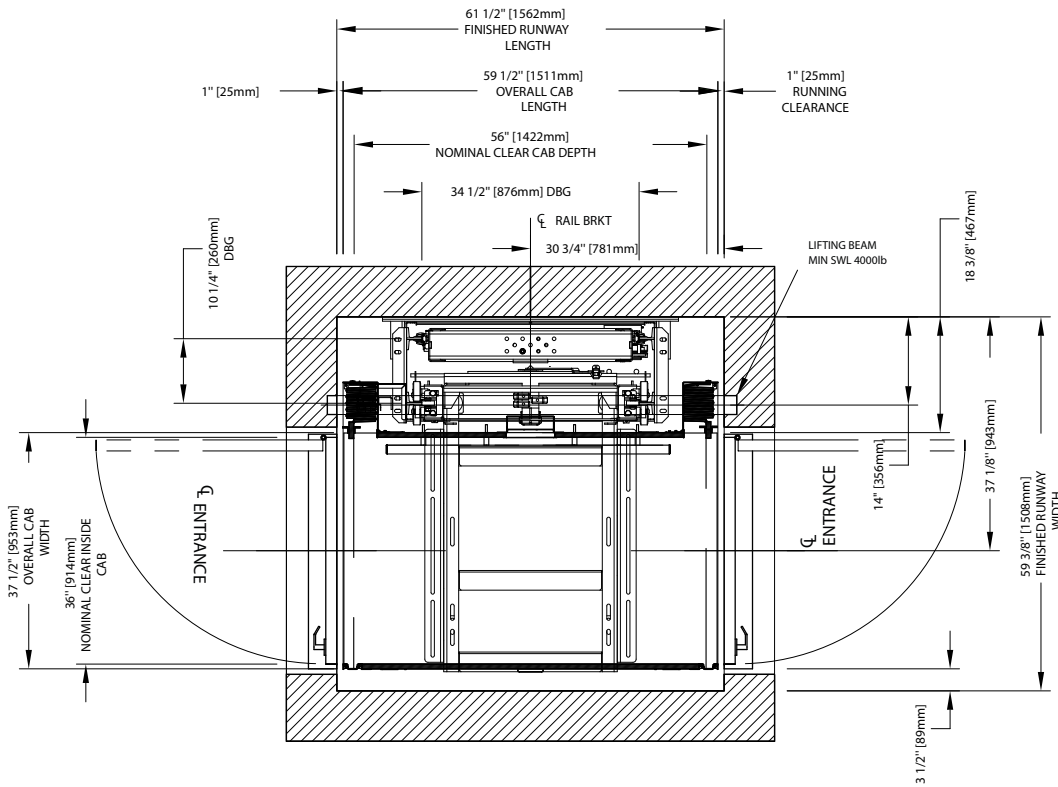

**IMPORTANT**

Finished hoistway dimensions must include the drywall. Determine the fire rating of the hoistway and the type and layers of sheet rock. Build only from the final shop drawings specific to your installation.

### 36" x 54" Type 3 Cab, Panel-fold Doors

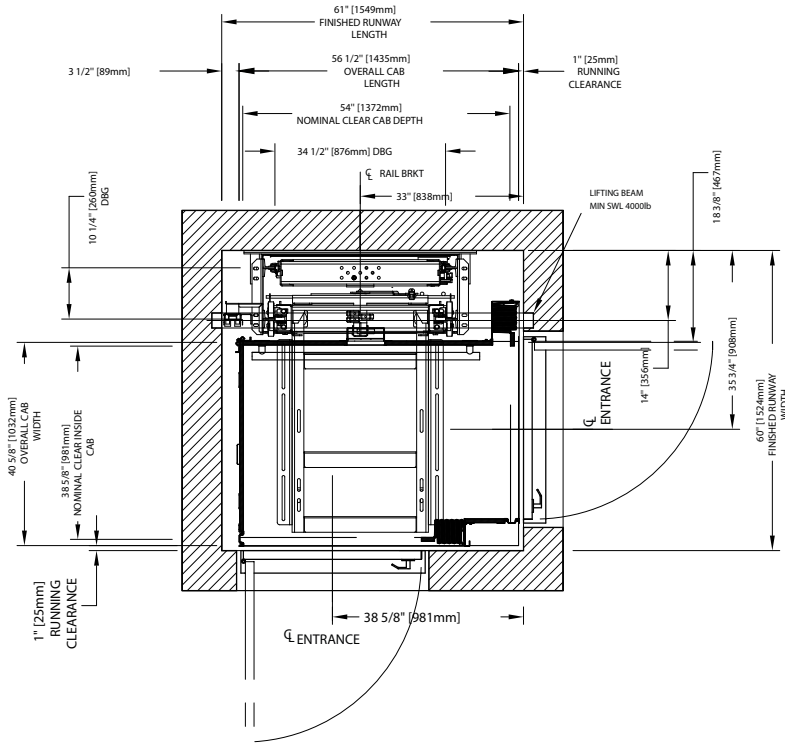

### 36" x 54" Type 4 Cab, Panel-fold Doors

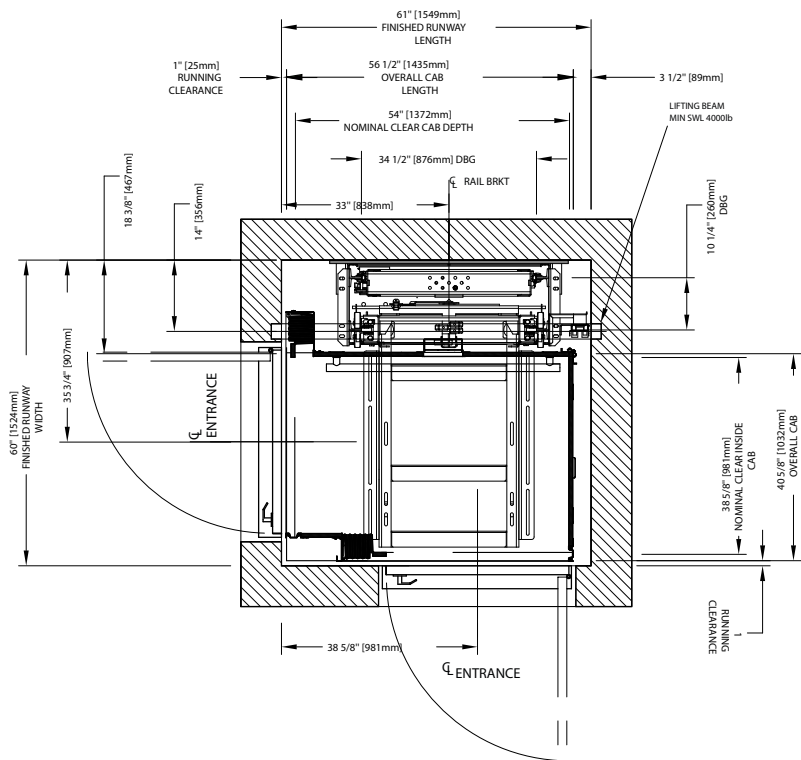

**IMPORTANT**

Finished hoistway dimensions must include the drywall. Determine the fire rating of the hoistway and the type and layers of sheet rock. Build only from the final shop drawings specific to your installation.

### 36" x 60" Type 1L Cab, Panel-fold Doors

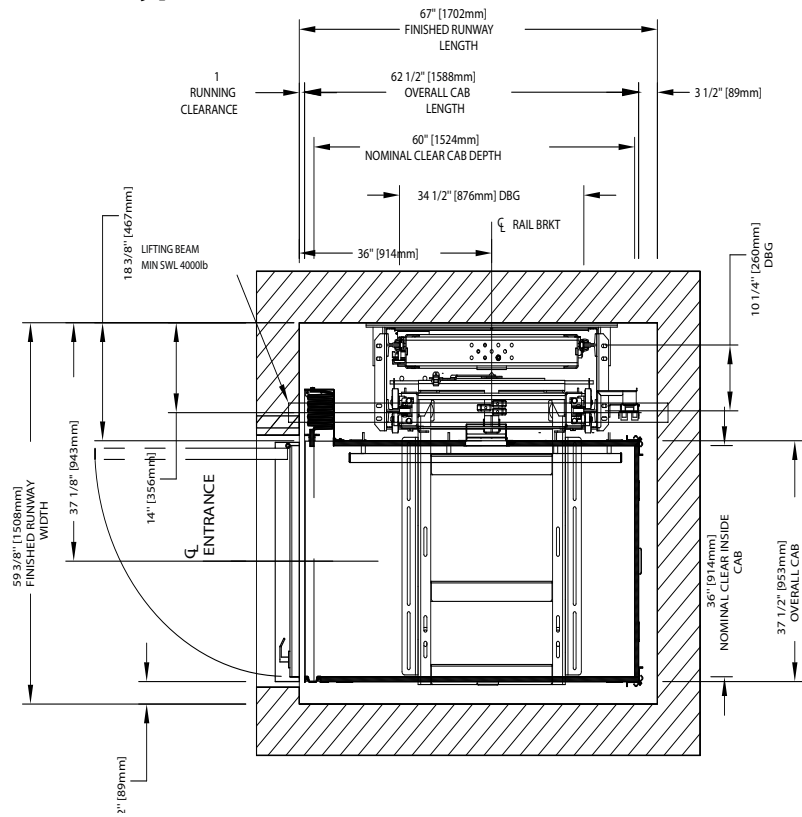

### 36" x 60" Type 1R Cab, Panel-fold Doors

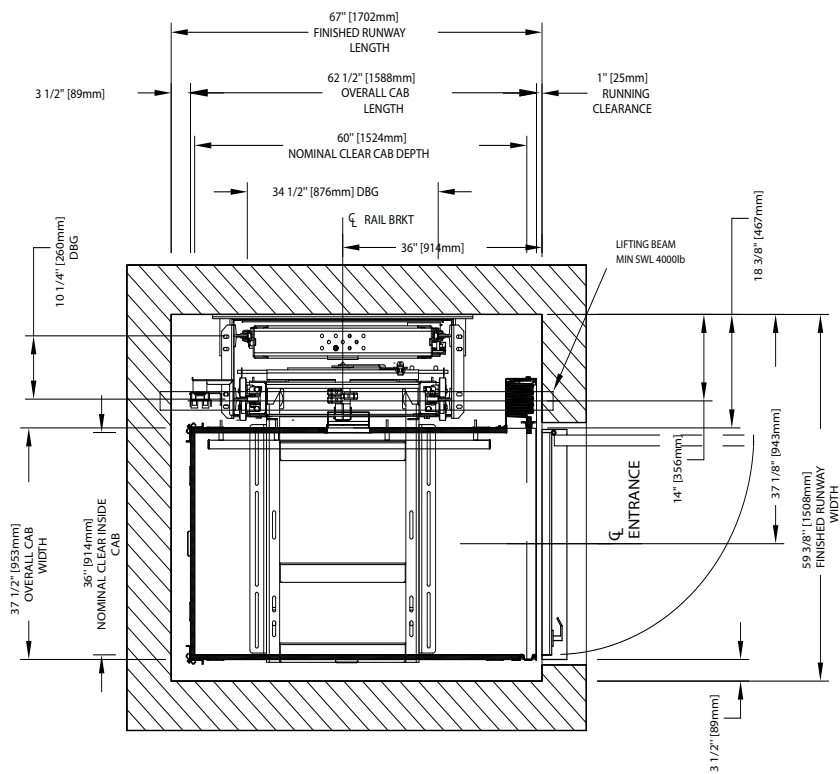

**IMPORTANT**

Finished hoistway dimensions must include the drywall. Determine the fire rating of the hoistway and the type and layers of sheet rock. Build only from the final shop drawings specific to your installation.

### 36" x 60" Type 2 Cab, Panel-fold Doors

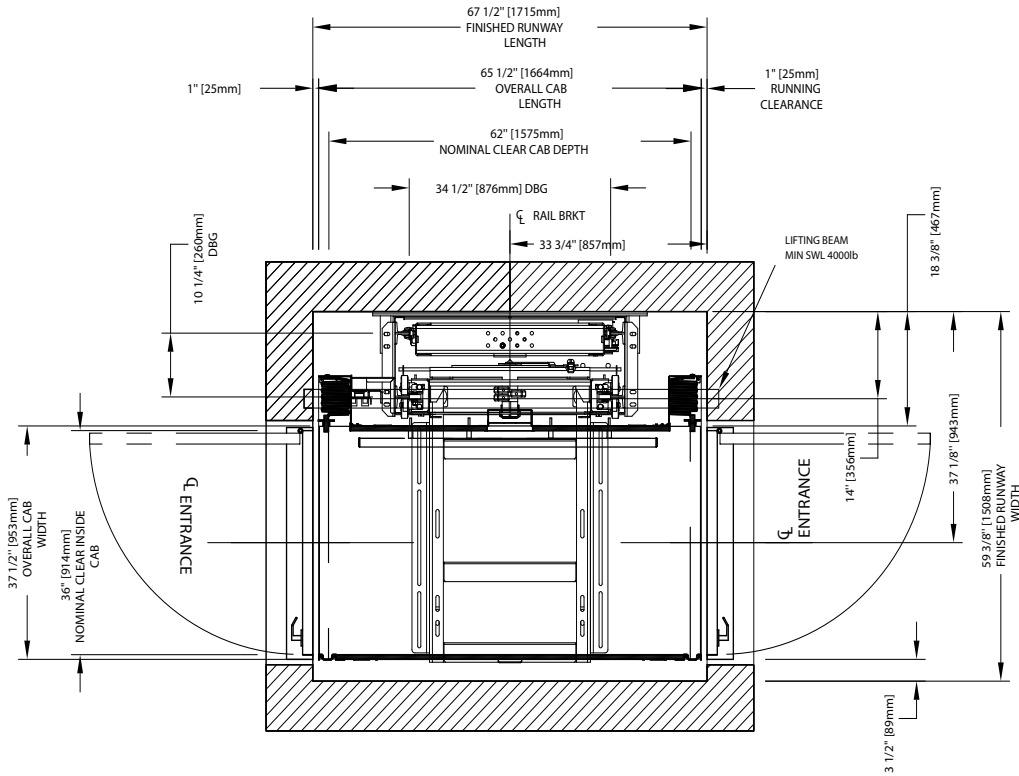

### 36" x 60" Type 3 Cab, Panel-fold Doors

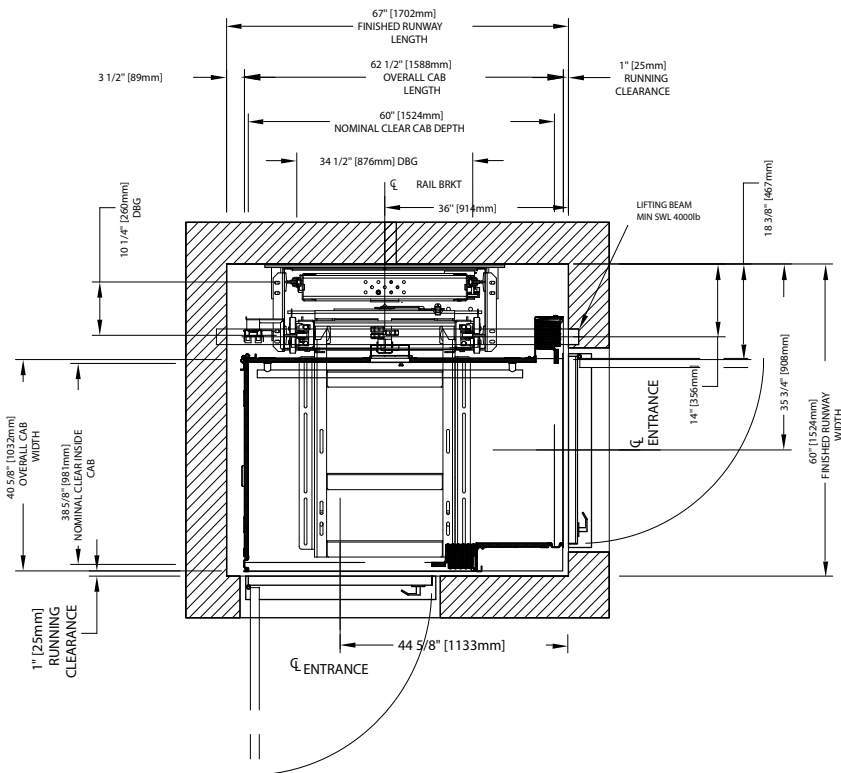

**IMPORTANT**

Finished hoistway dimensions must include the drywall. Determine the fire rating of the hoistway and the type and layers of sheet rock. Build only from the final shop drawings specific to your installation.



### 36" x 60" Type 4 Cab, Panel-fold Doors

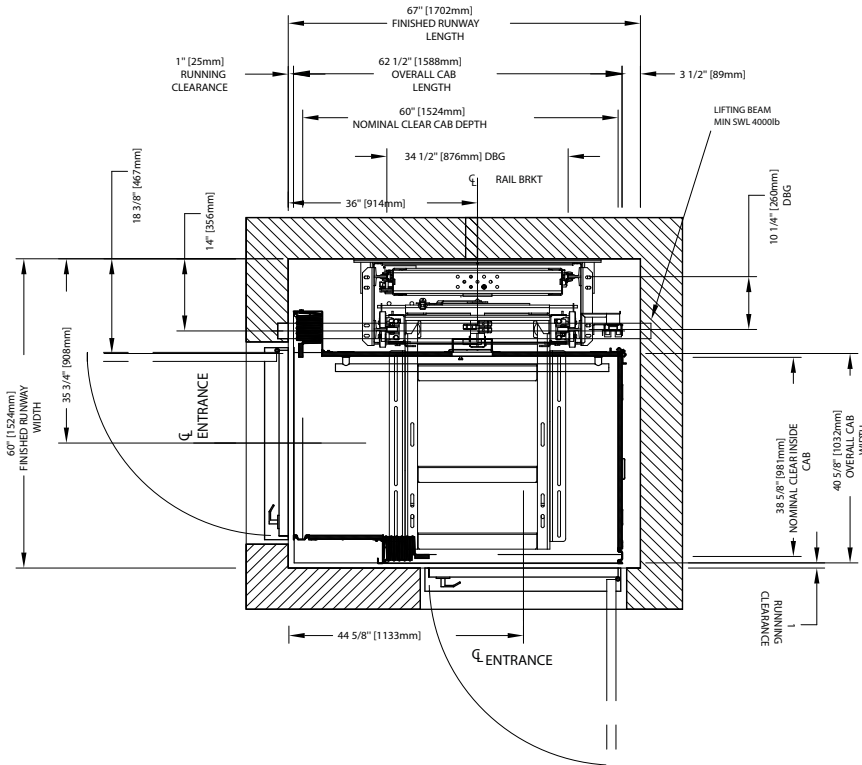

### 36" x 60" Type 5-3 Cab, Panel-fold Doors

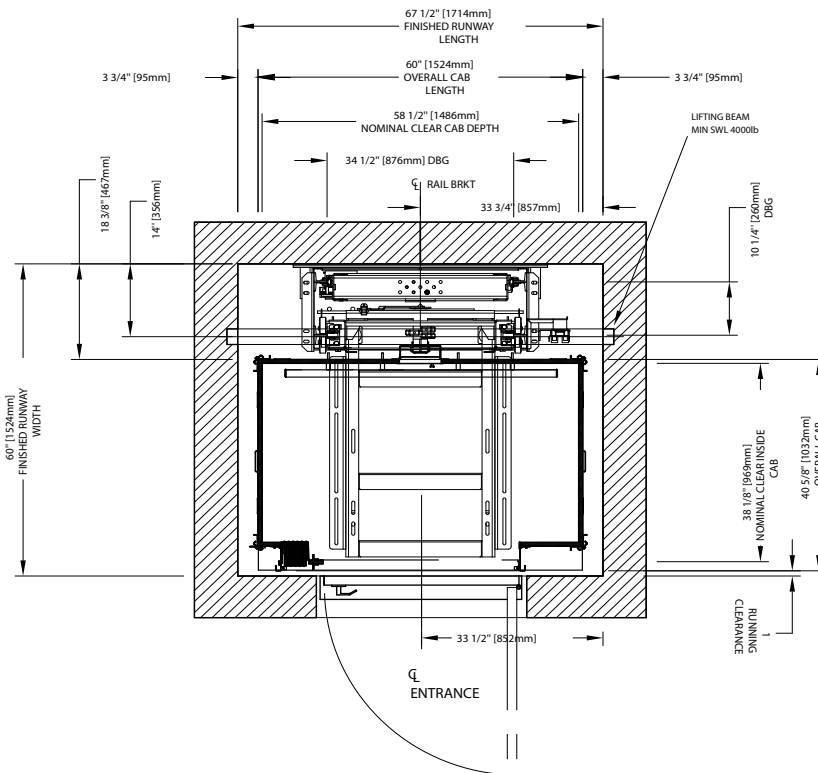

**IMPORTANT**

Finished hoistway dimensions must include the drywall. Determine the fire rating of the hoistway and the type and layers of sheet rock. Build only from the final shop drawings specific to your installation.

### 36" x 60" Type 5-4 Cab, Panel-fold Doors

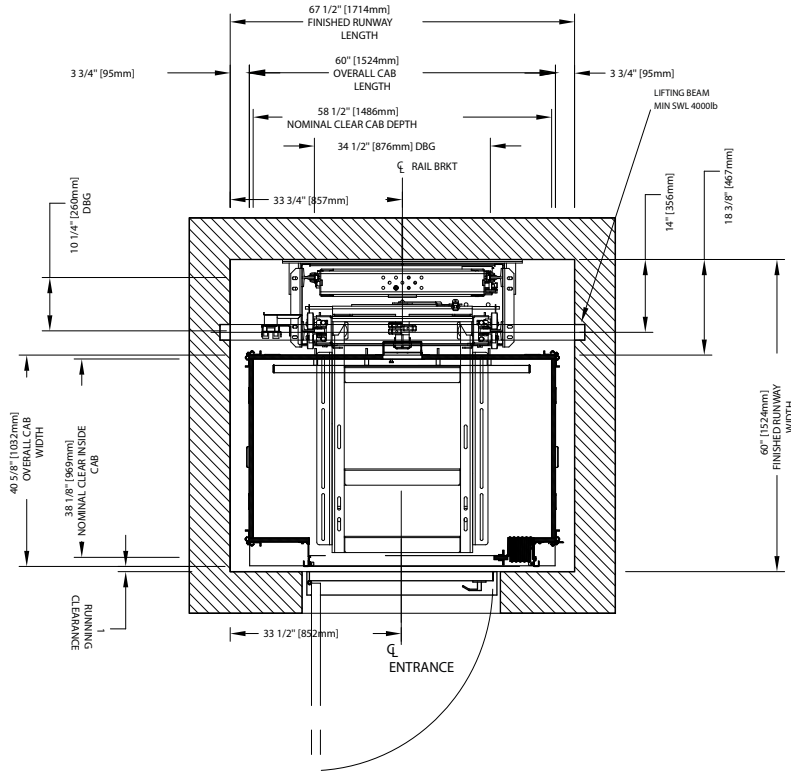

### 40" x 54" Type 1L Cab, Panel-fold Doors

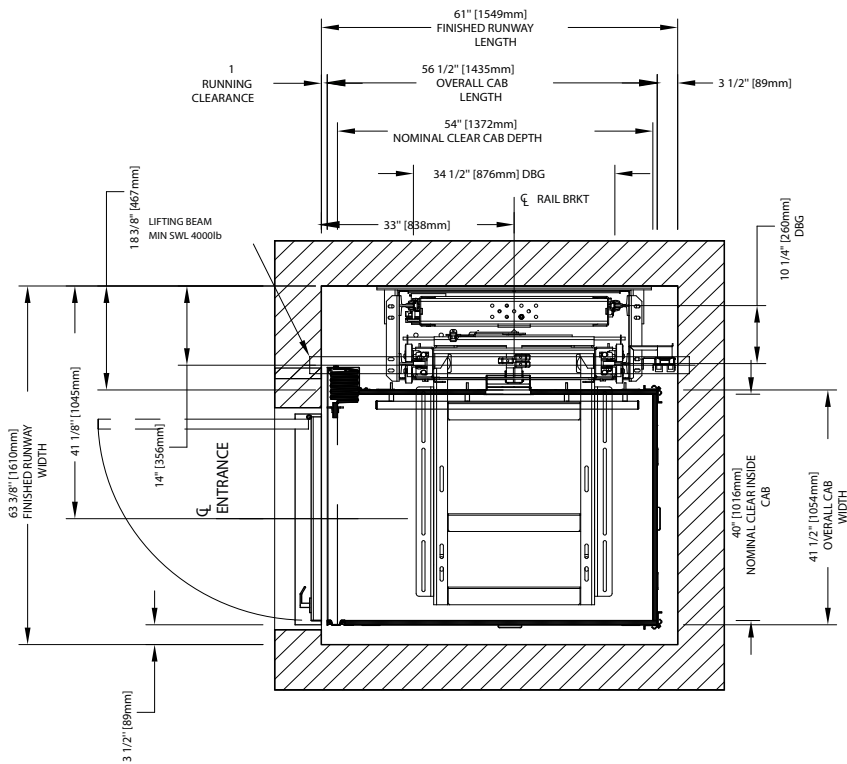

**IMPORTANT**

Finished hoistway dimensions must include the drywall. Determine the fire rating of the hoistway and the type and layers of sheet rock. Build only from the final shop drawings specific to your installation.

### 40" x 54" Type 1R Cab, Panel-fold Doors

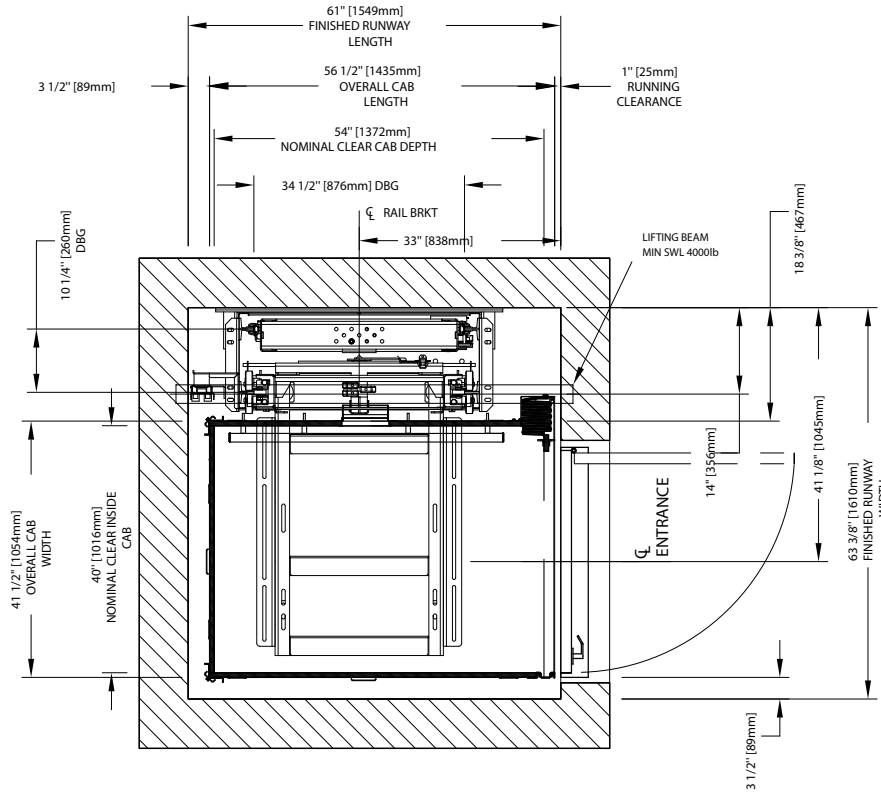

### 40" x 54" Type 2 Cab, Panel-fold Doors

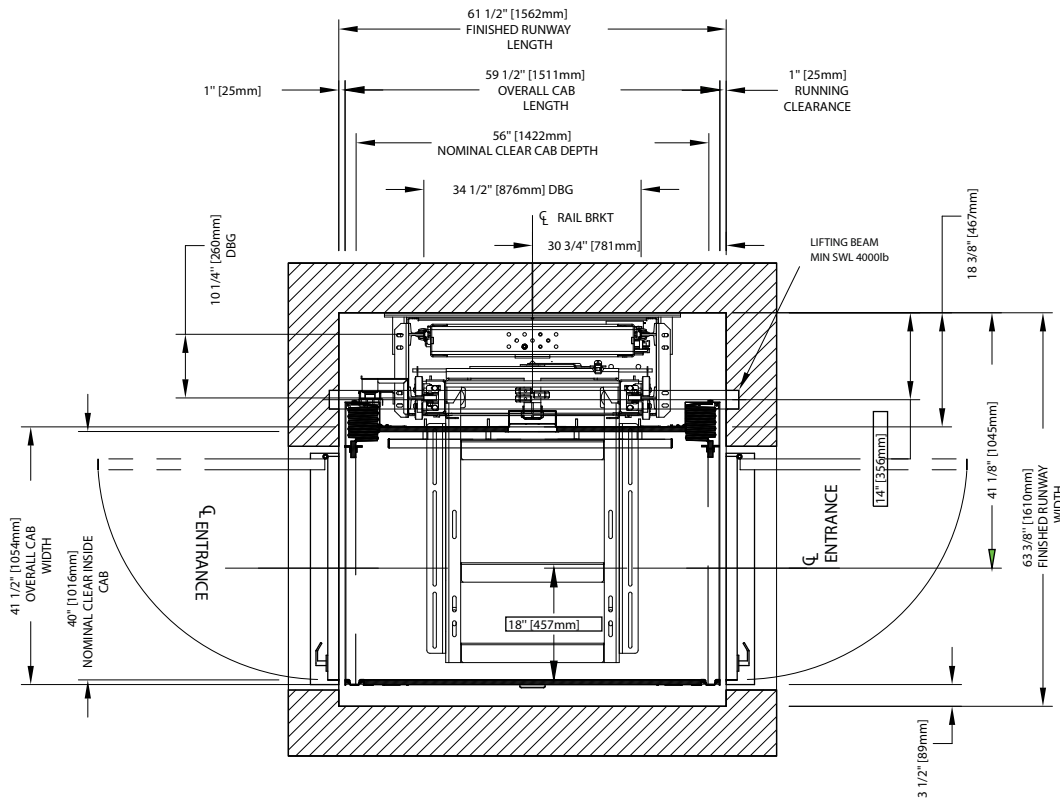

**IMPORTANT**

Finished hoistway dimensions must include the drywall. Determine the fire rating of the hoistway and the type and layers of sheet rock. Build only from the final shop drawings specific to your installation.

## 40" x 54" Type 3 Cab, Panel-fold Doors

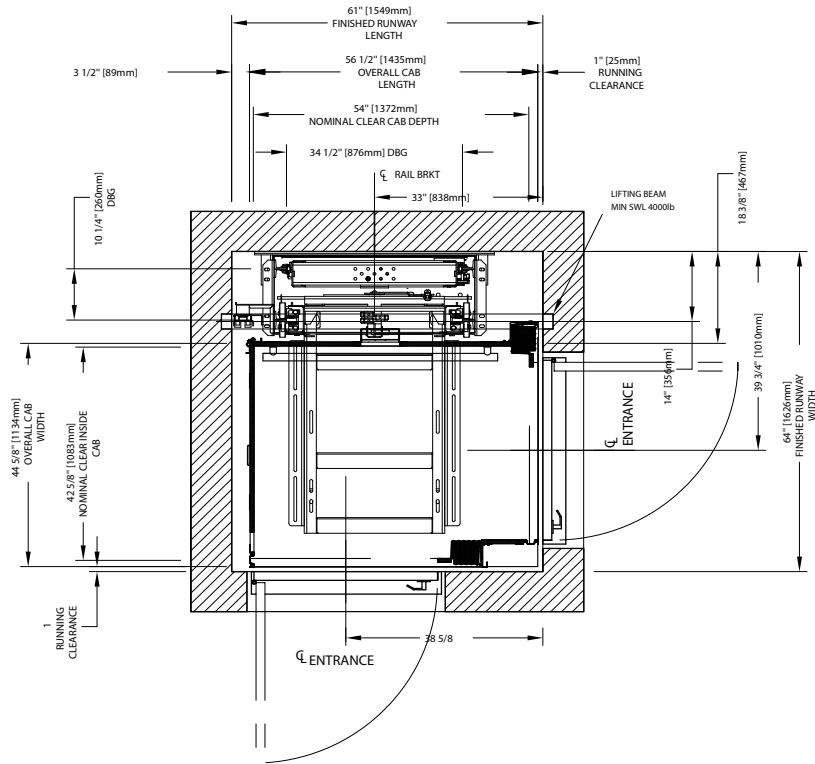

## 40" x 54" Type 4 Cab, Panel-fold Doors

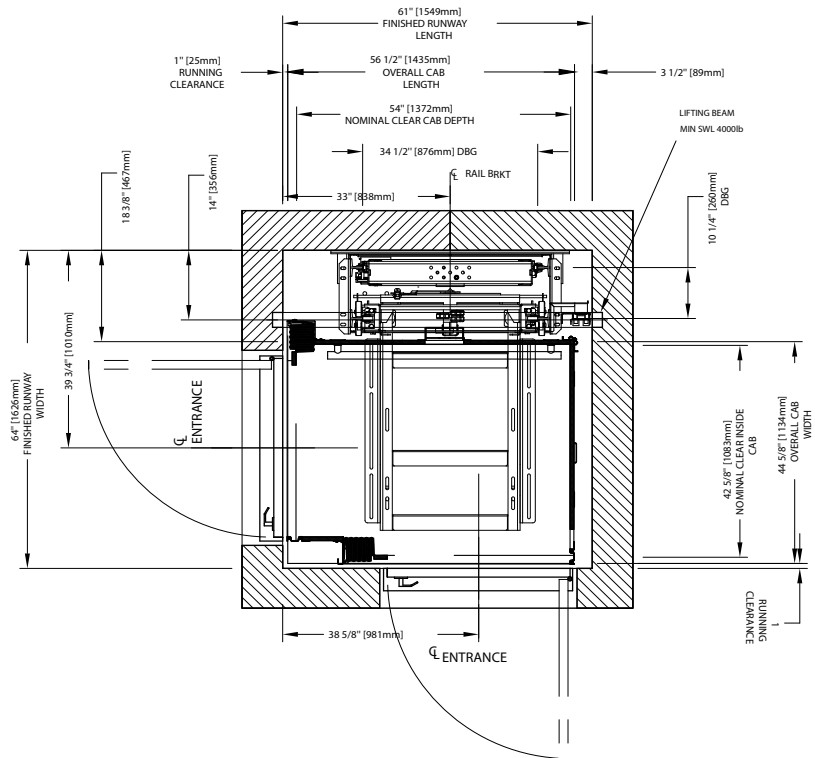

### IMPORTANT

Finished hoistway dimensions must include the drywall. Determine the fire rating of the hoistway and the type and layers of sheet rock. Build only from the final shop drawings specific to your installation.

### Sample Elevation View, Bi-fold Doors

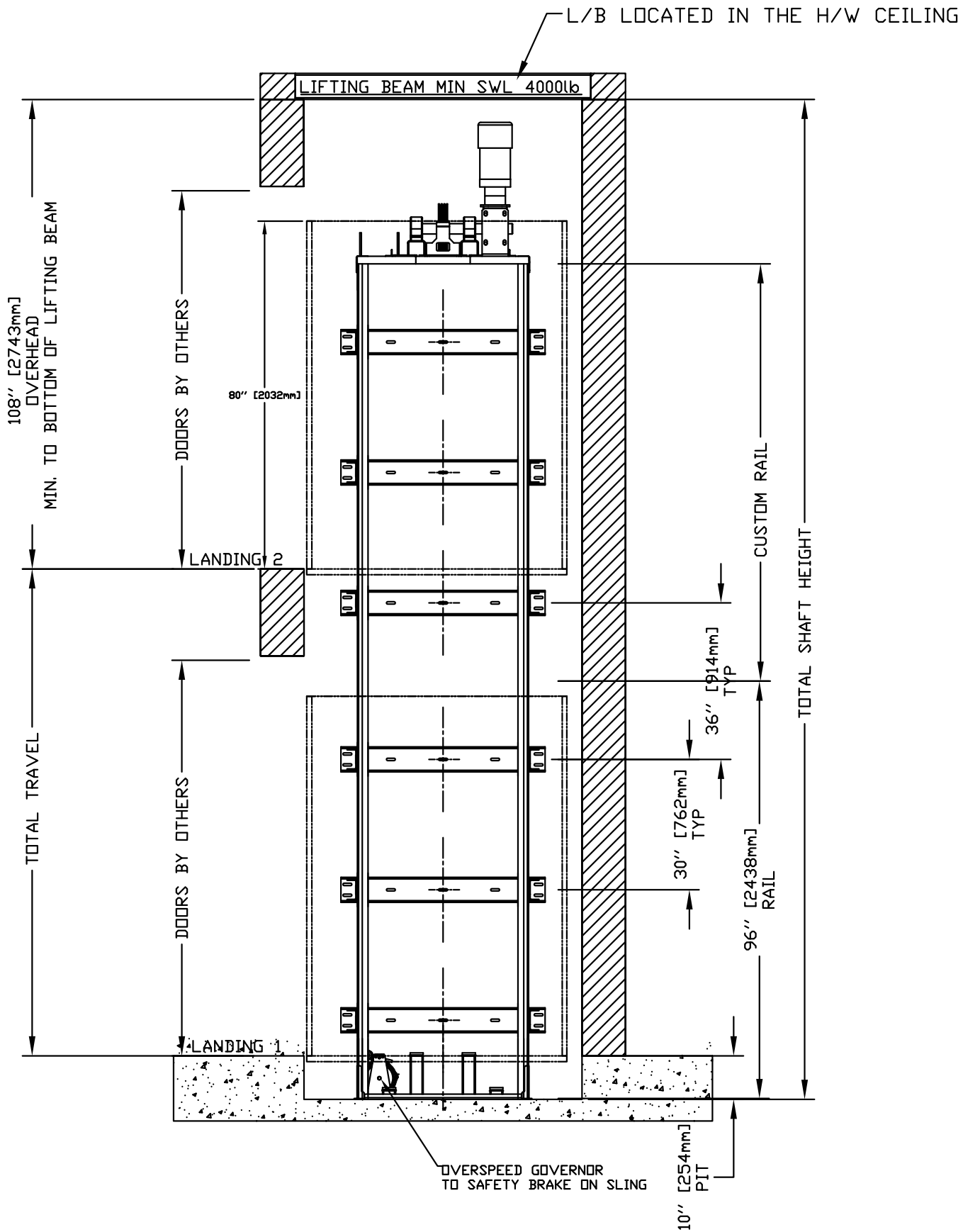

### 36" x 48" Type 1L Cab, Bi-fold Doors

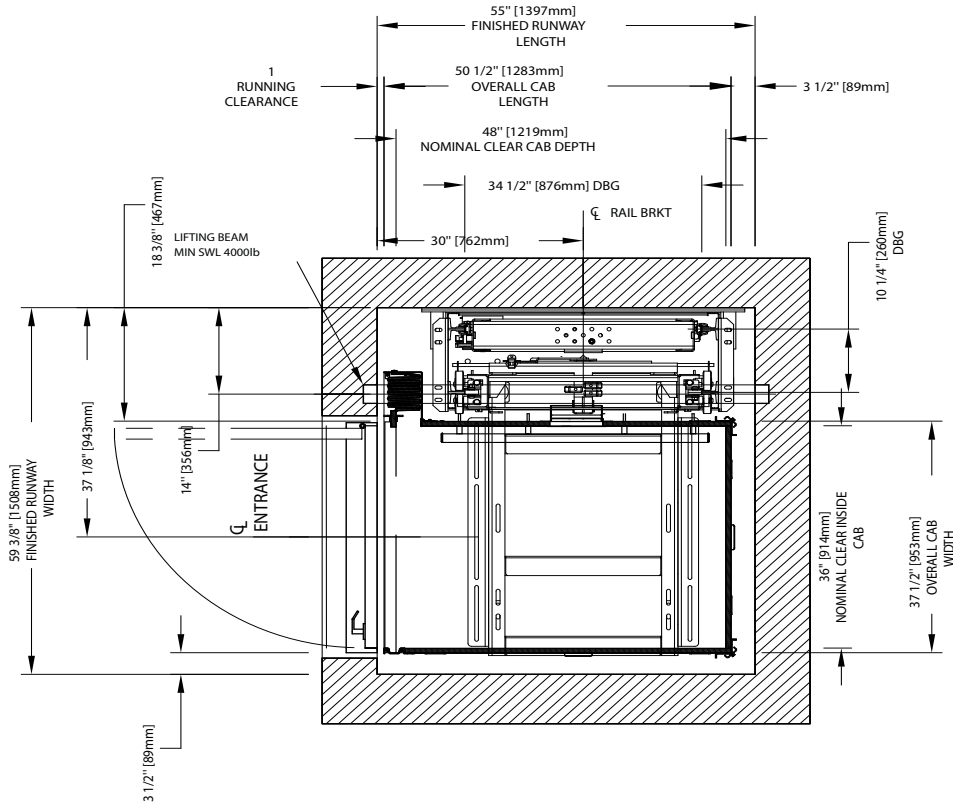

### 36" x 48" Type 1R Cab, Bi-fold Doors

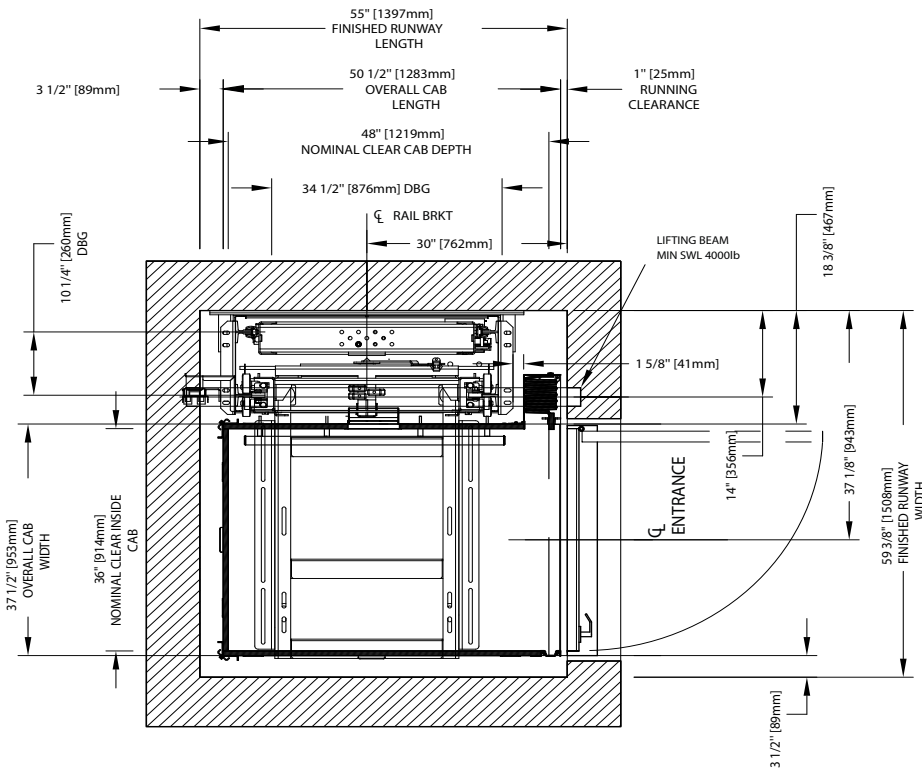

**IMPORTANT**

Finished hoistway dimensions must include the drywall. Determine the fire rating of the hoistway and the type and layers of sheet rock. Build only from the final shop drawings specific to your installation.

### 36" x 48" Type 2 Cab, Bi-fold Doors

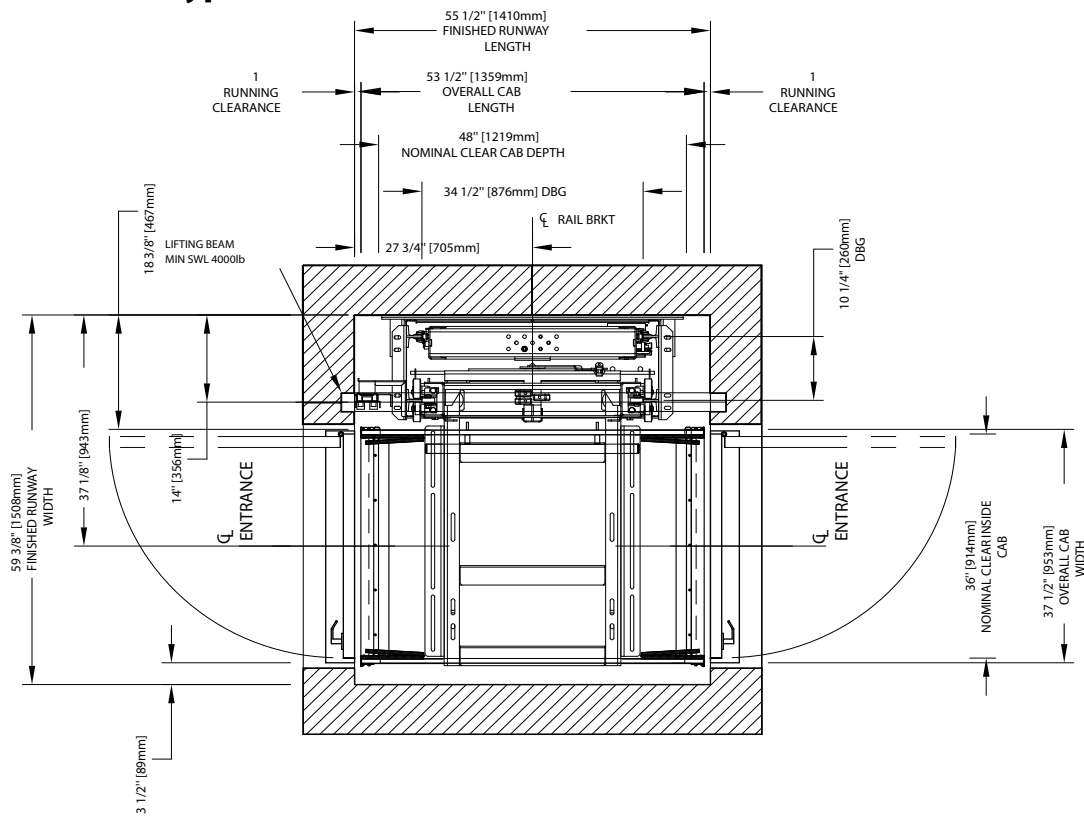

### 36" x 54" Type 1L Cab, Bi-fold Doors

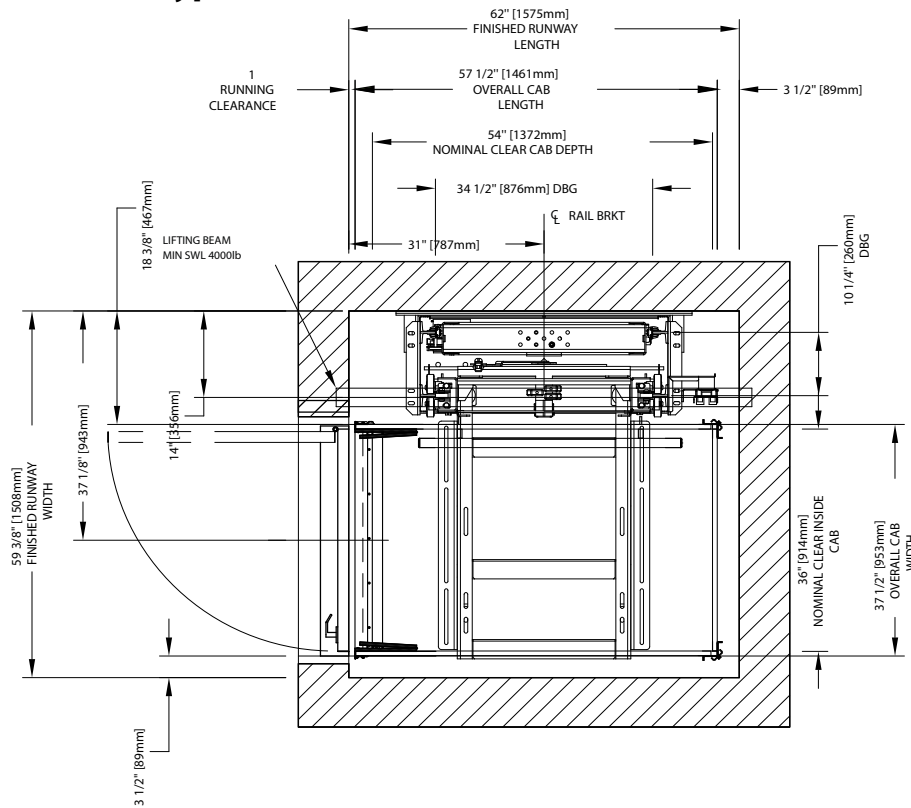

**IMPORTANT**

Finished hoistway dimensions must include the drywall. Determine the fire rating of the hoistway and the type and layers of sheet rock. Build only from the final shop drawings specific to your installation.

### 36" x 54" Type 1R Cab, Bi-fold Doors

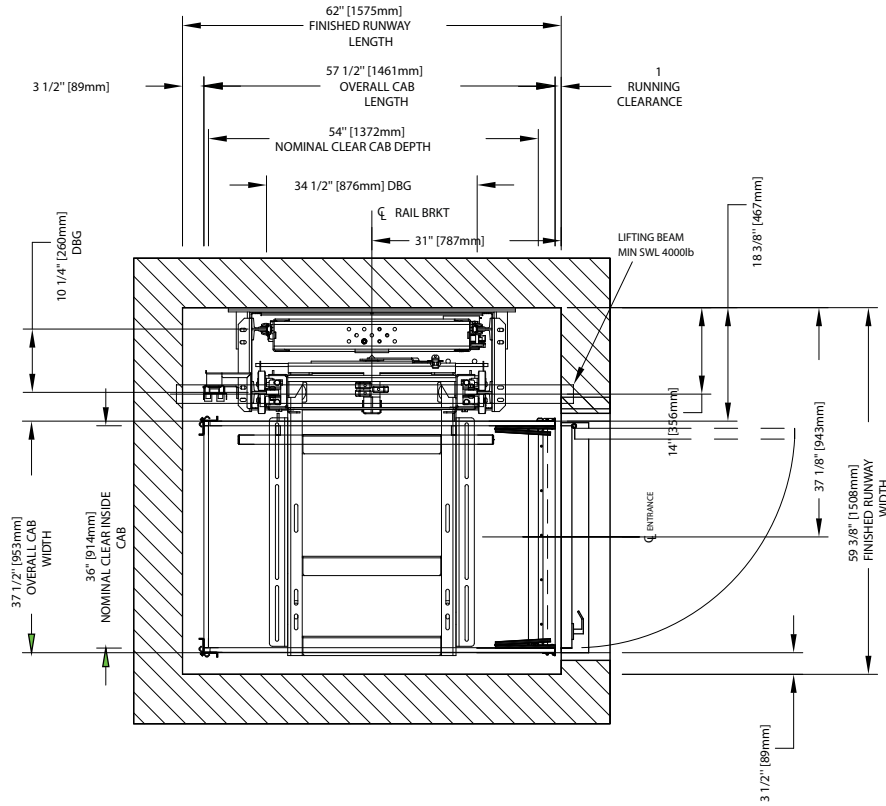

### 36" x 54" Type 2 Cab, Bi-fold Doors

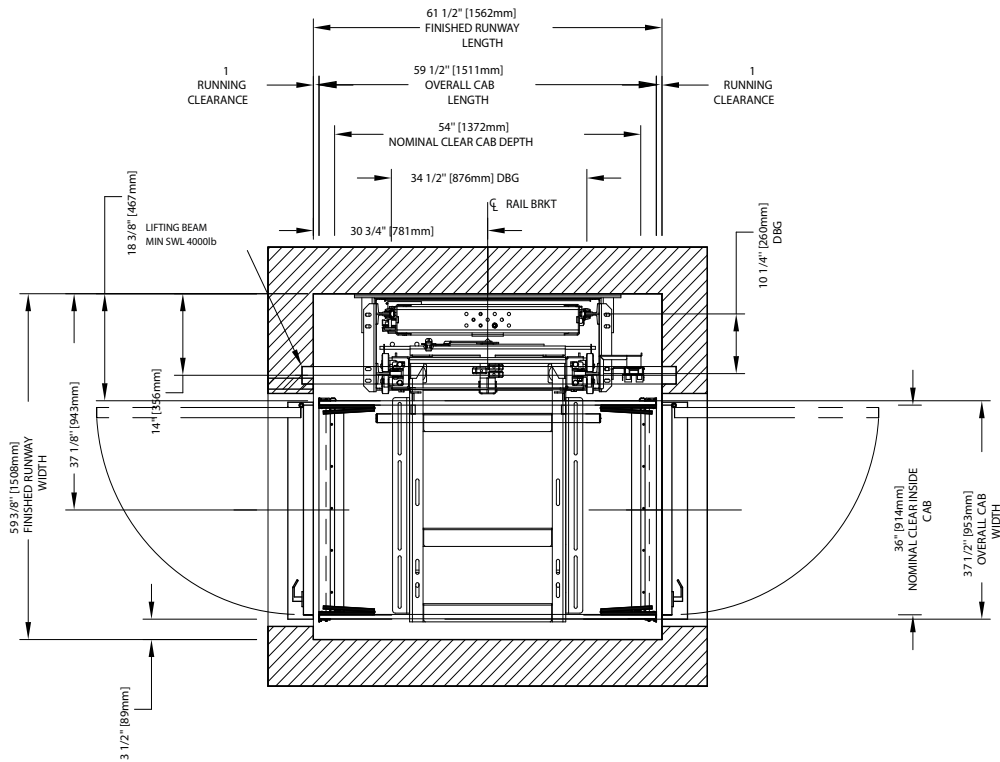

**IMPORTANT**

Finished hoistway dimensions must include the drywall. Determine the fire rating of the hoistway and the type and layers of sheet rock. Build only from the final shop drawings specific to your installation.



### 36" x 60" Type 1L Cab, Bi-fold Doors

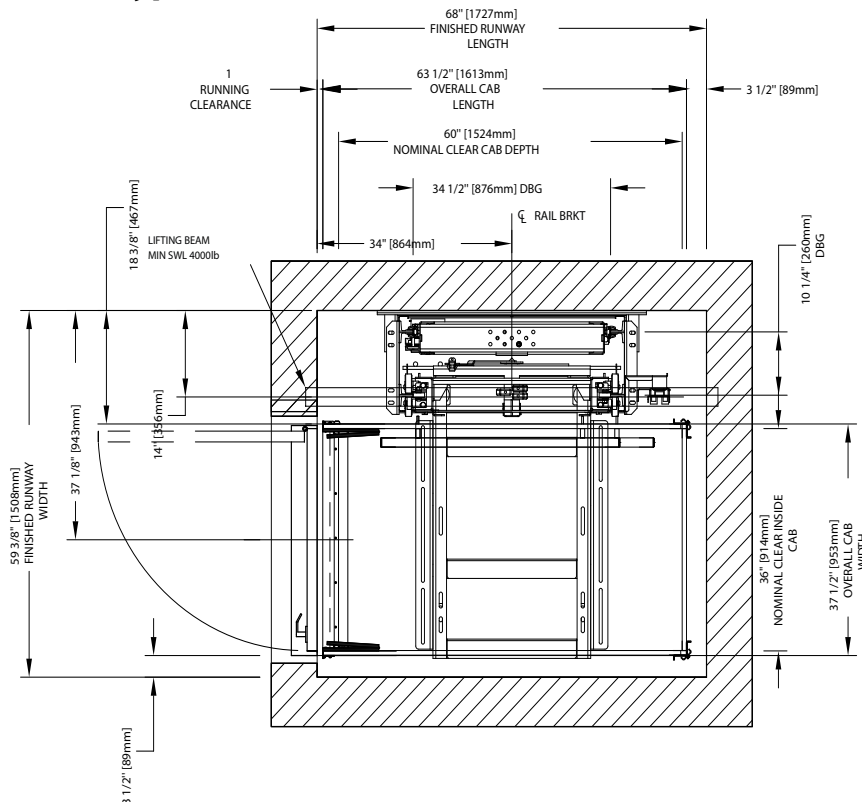

### 36" x 60" Type 1R Cab, Bi-fold Doors

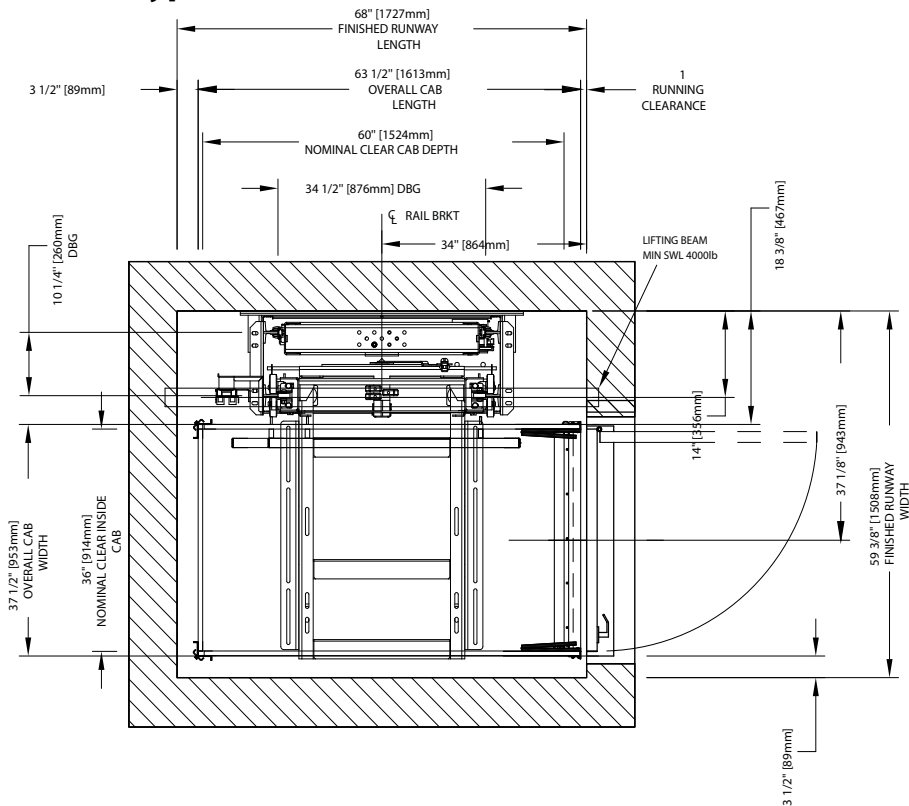

**IMPORTANT**

Finished hoistway dimensions must include the drywall. Determine the fire rating of the hoistway and the type and layers of sheet rock. Build only from the final shop drawings specific to your installation.

### 36" x 60" Type 2 Cab, Bi-fold Doors

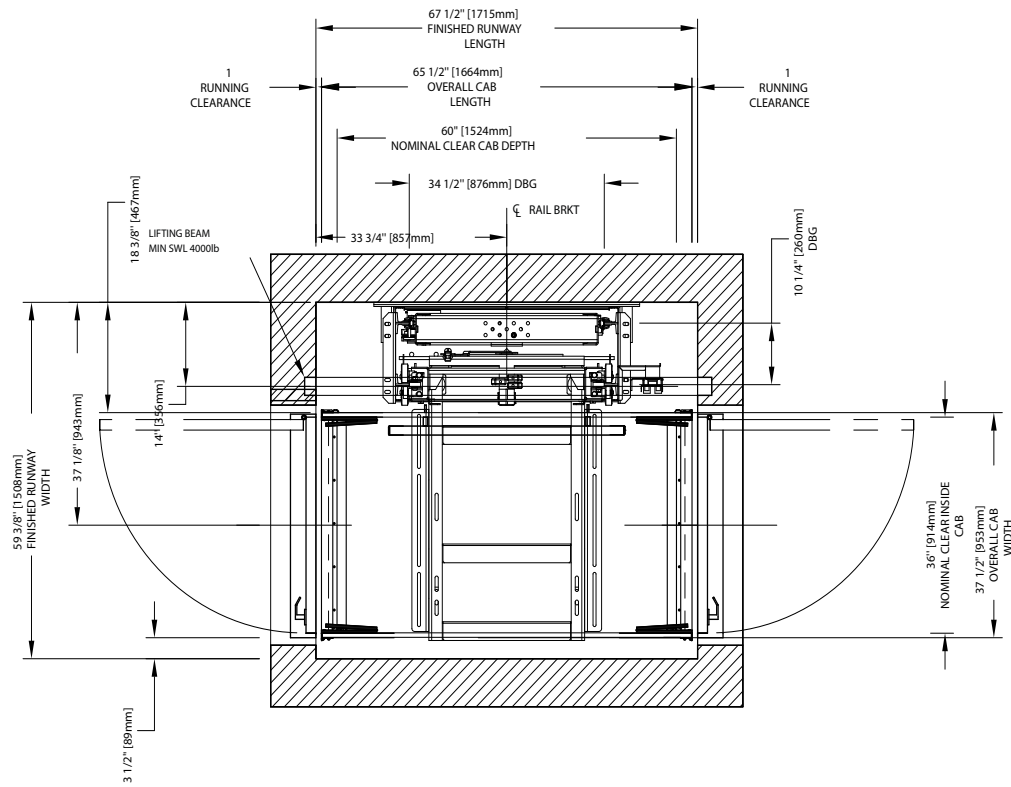

### 40" x 48" Type 1L Cab, Bi-fold Doors

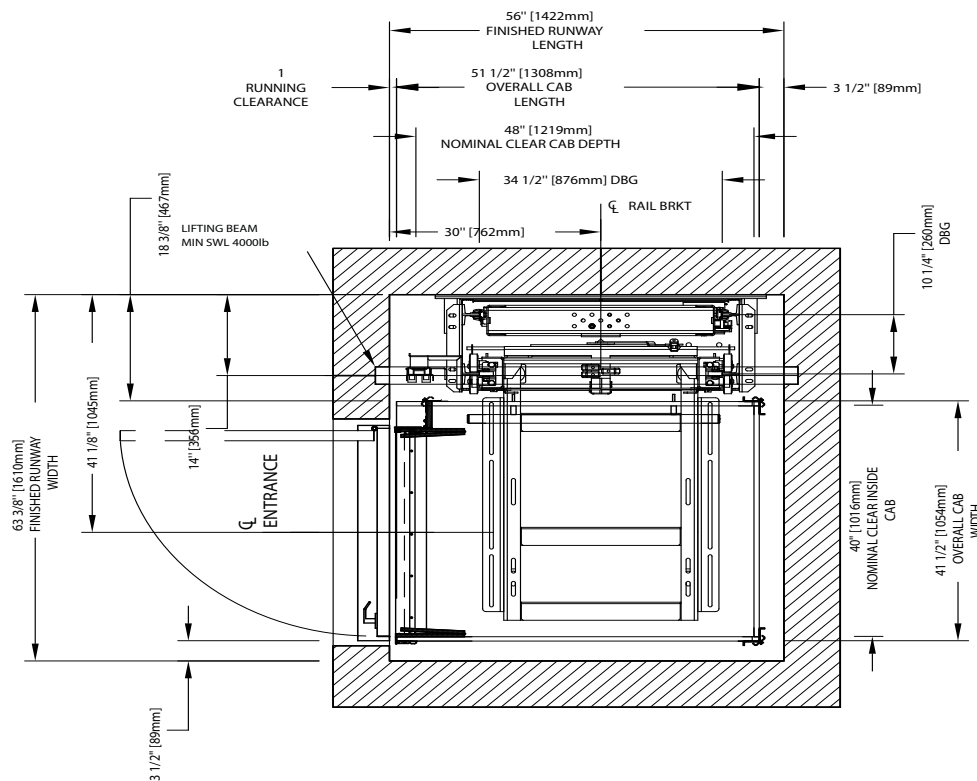

**IMPORTANT**

Finished hoistway dimensions must include the drywall. Determine the fire rating of the hoistway and the type and layers of sheet rock. Build only from the final shop drawings specific to your installation.

### 40" x 48" Type 1R Cab, Bi-fold Doors

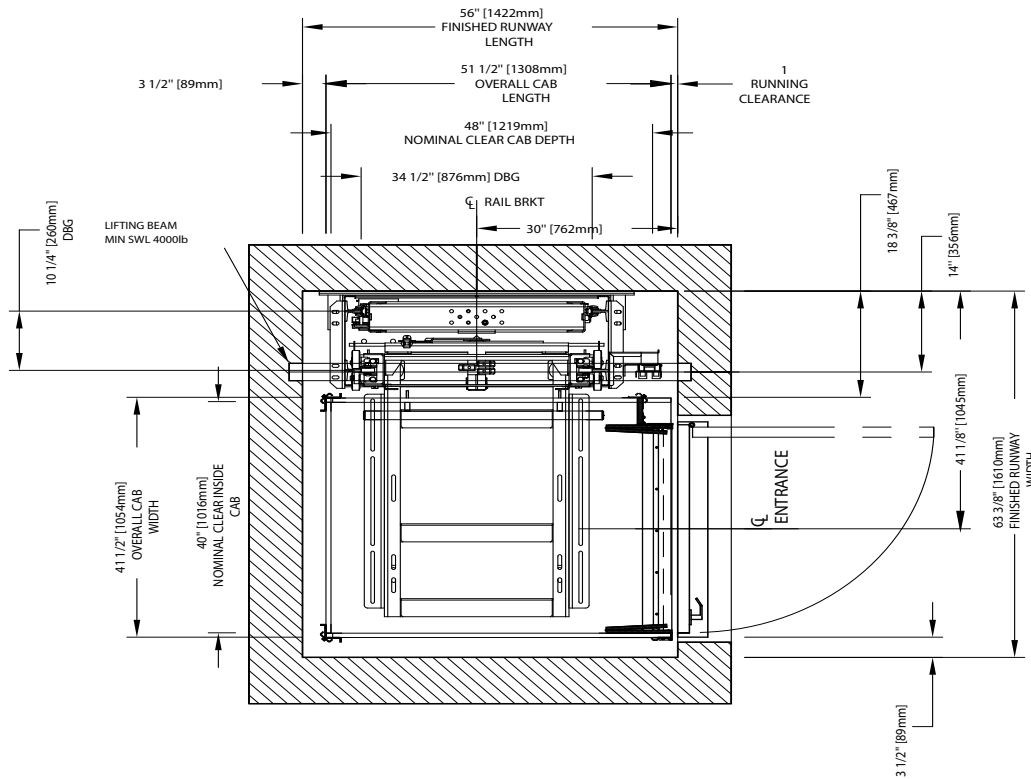

### 40" x 48" Type 2 Cab, Bi-fold Doors

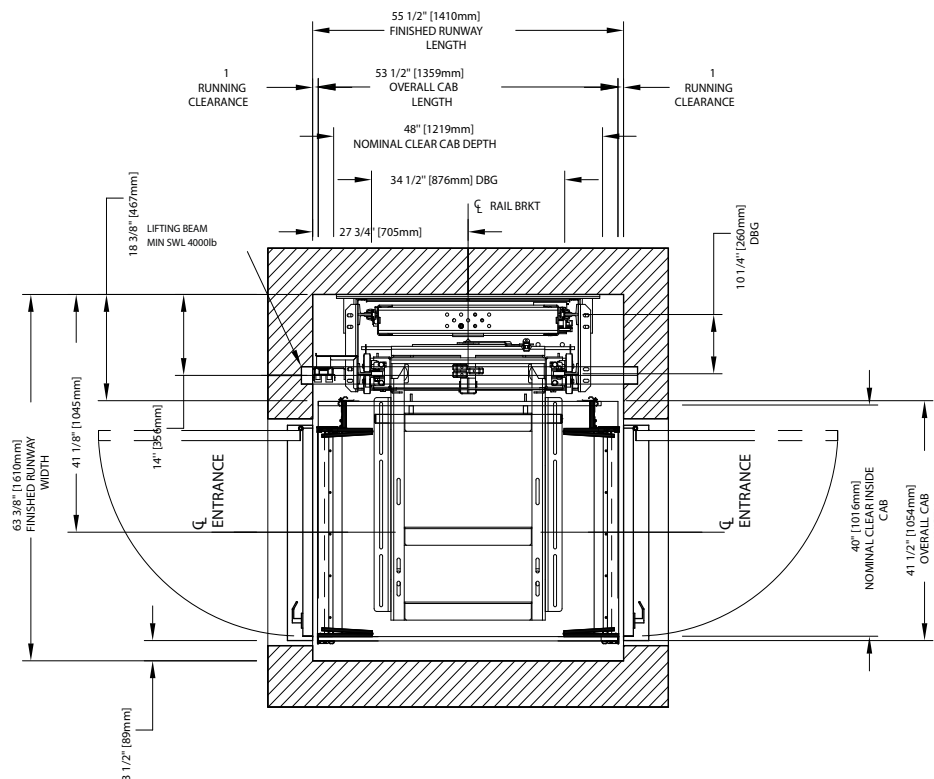

**IMPORTANT**

Finished hoistway dimensions must include the drywall. Determine the fire rating of the hoistway and the type and layers of sheet rock. Build only from the final shop drawings specific to your installation.

## 40" x 54" Type 1L Cab, Bi-fold Doors

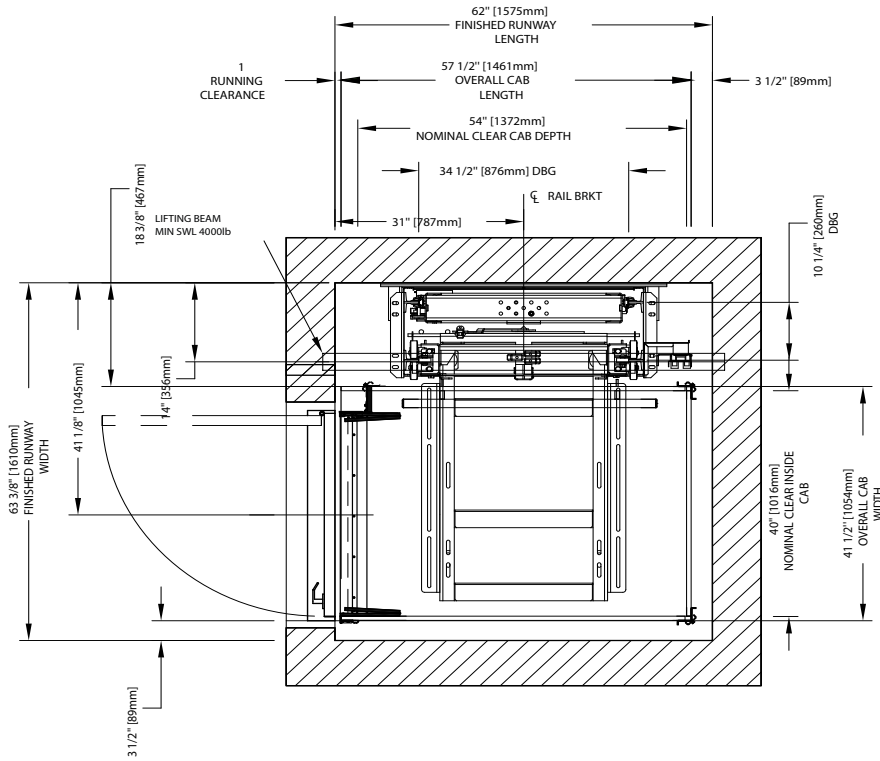

## 40" x 54" Type 1R Cab, Bi-fold Doors

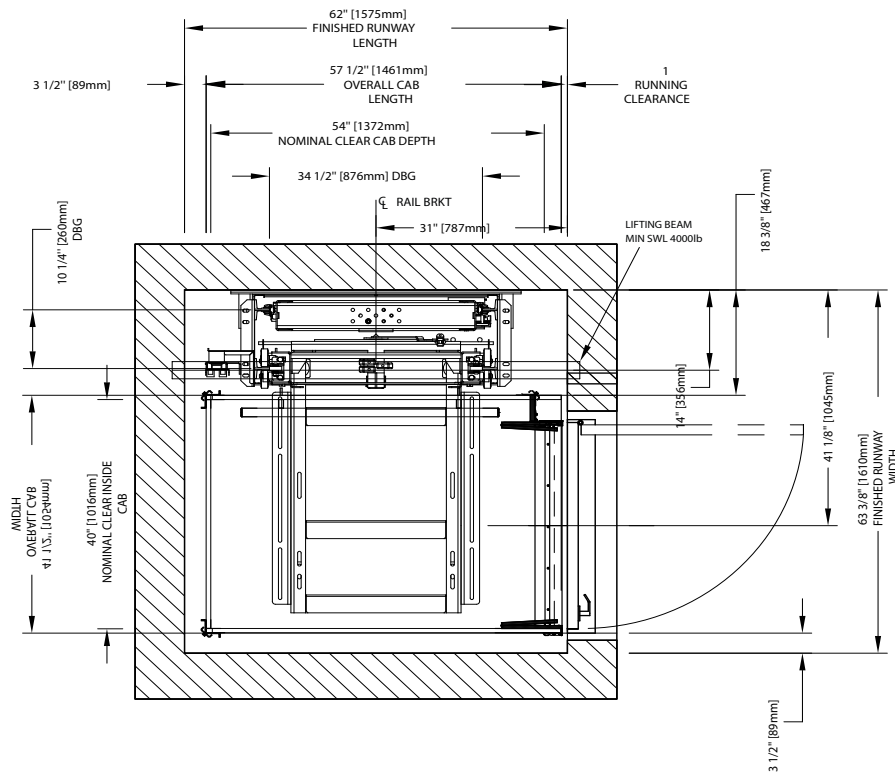

### IMPORTANT

Finished hoistway dimensions must include the drywall. Determine the fire rating of the hoistway and the type and layers of sheet rock. Build only from the final shop drawings specific to your installation.

# 40" x 54" Type 2 Cab, Bi-fold Doors

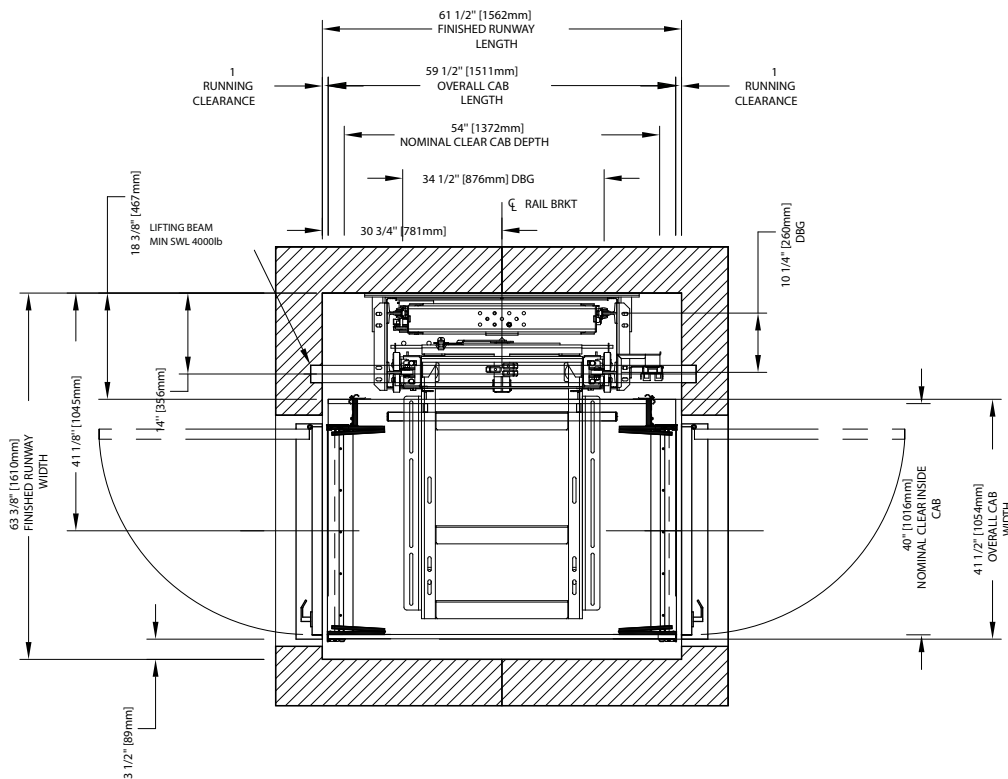

**IMPORTANT**

Finished hoistway dimensions must include the drywall. Determine the fire rating of the hoistway and the type and layers of sheet rock. Build only from the final shop drawings specific to your installation.

# Sample Elevation View, Auto Slim Doors

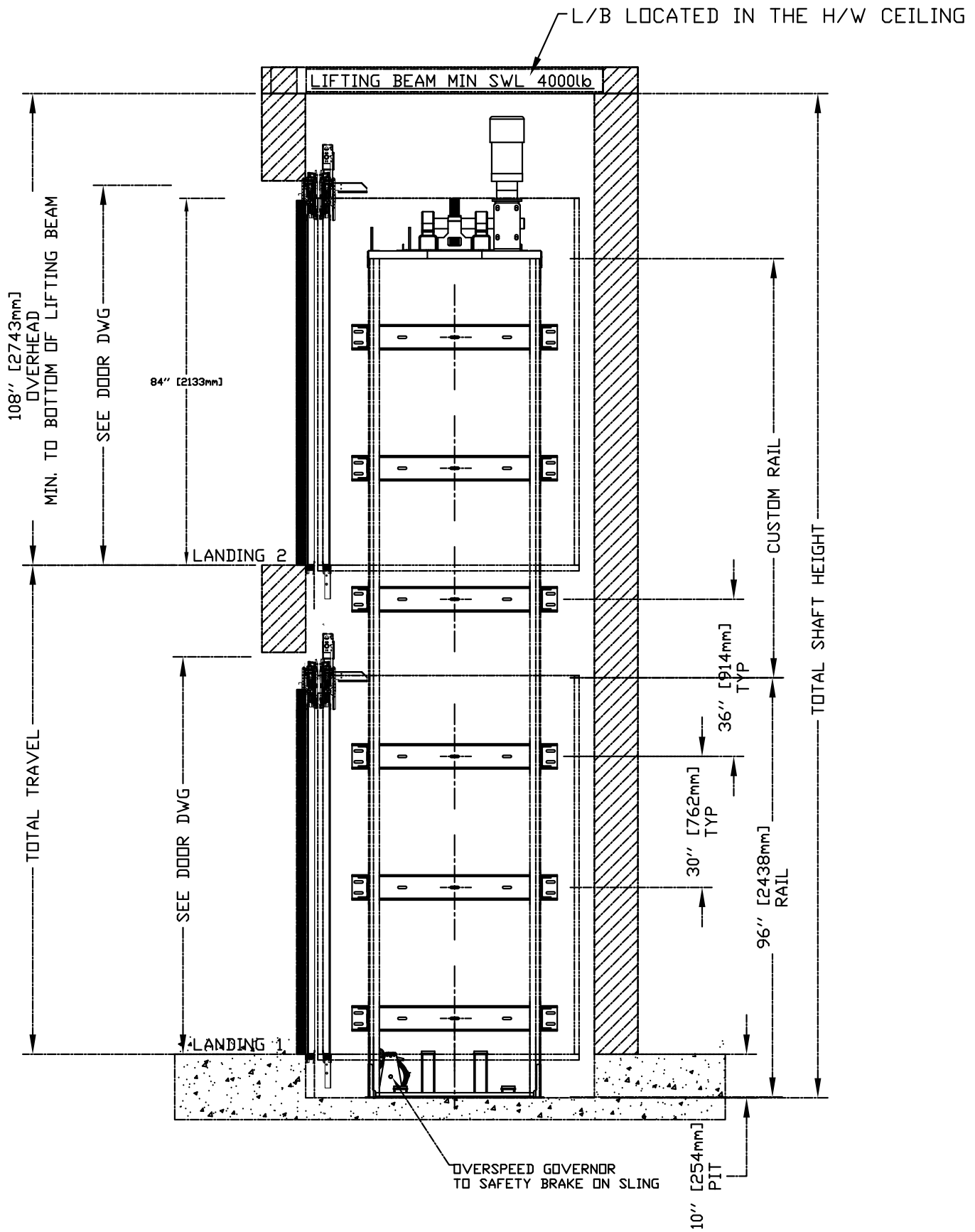

### 36" x 48" Type 1L Cab, Auto Slim (35.5") Doors

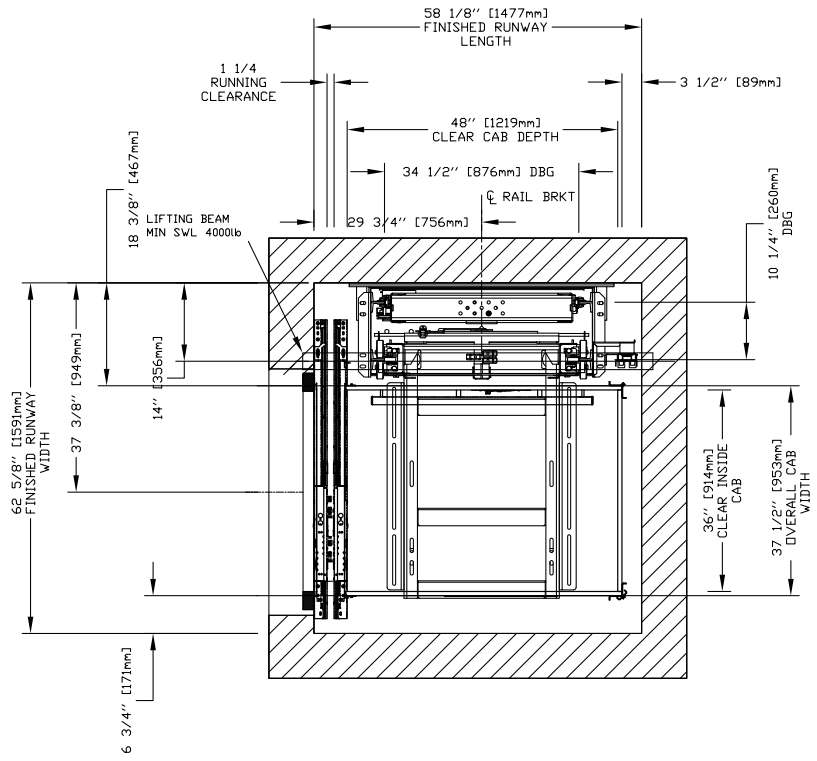

### 36" x 48" Type 1L Cab, Auto Slim (35.5") Doors + Swing

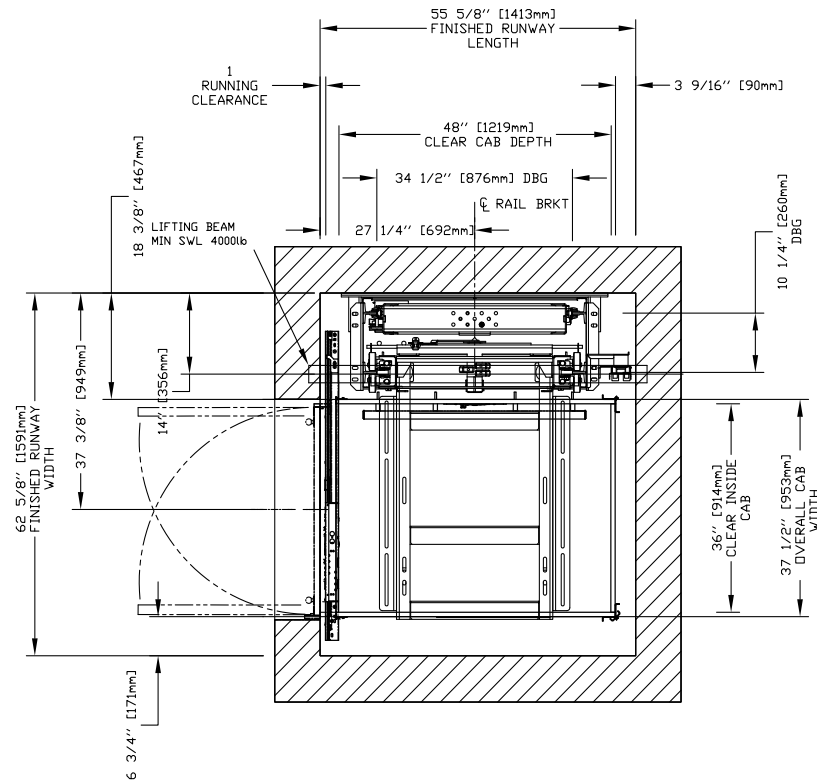

**IMPORTANT**

Finished hoistway dimensions must include the drywall. Determine the fire rating of the hoistway and the type and layers of sheet rock. Build only from the final shop drawings specific to your installation.

### 36" x 48" Type 1L Cab, Auto Slim (29.5") Doors

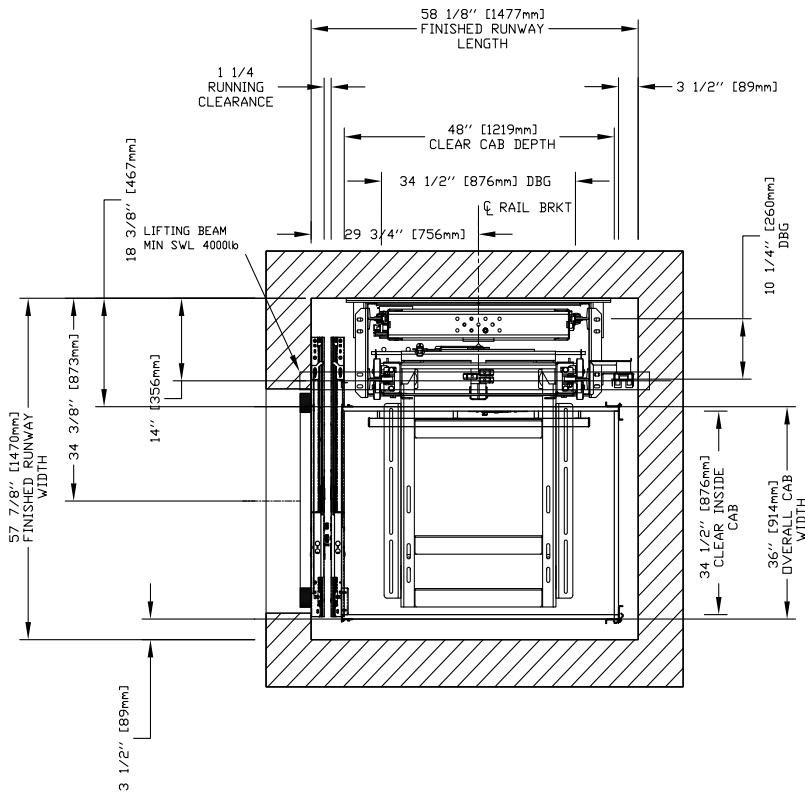

### 36" x 48" Type 1L Cab, Auto Slim (29.5") Doors + Swing

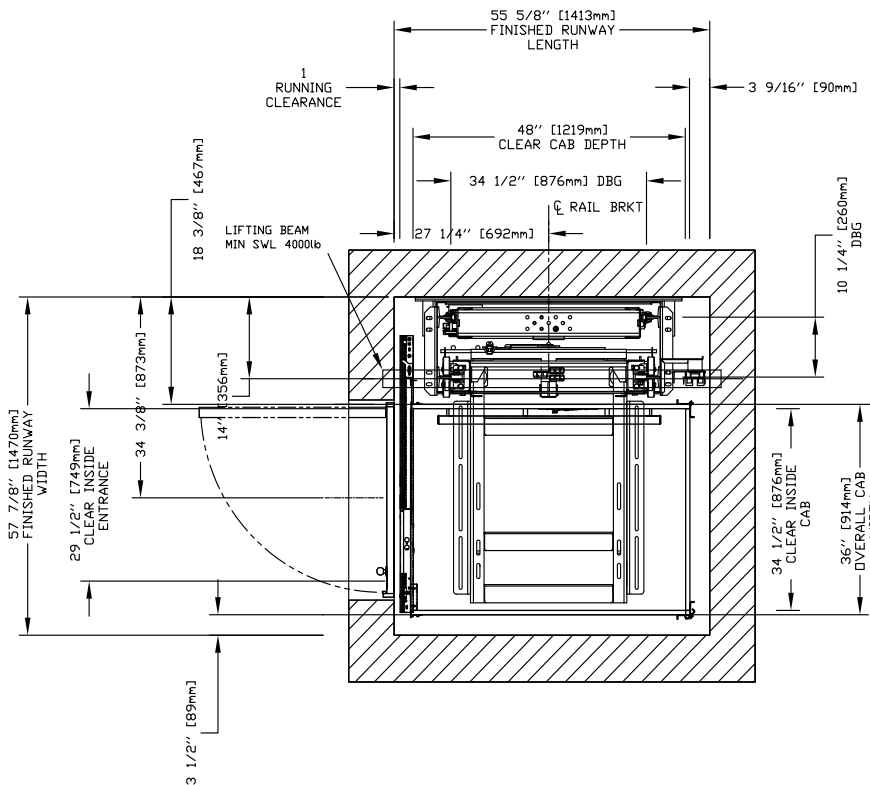

**IMPORTANT**

Finished hoistway dimensions must include the drywall. Determine the fire rating of the hoistway and the type and layers of sheet rock. Build only from the final shop drawings specific to your installation.



### 36" x 48" Type 1R Cab, Auto Slim (35.5") Doors

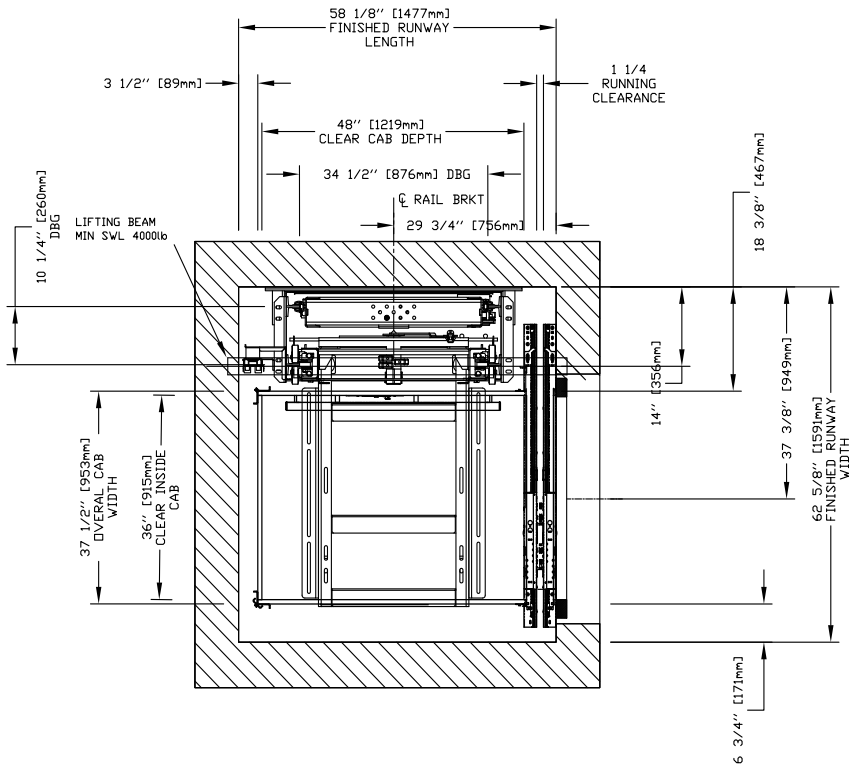

### 36" x 48" Type 1R Cab, Auto Slim (35.5") Doors + Swing

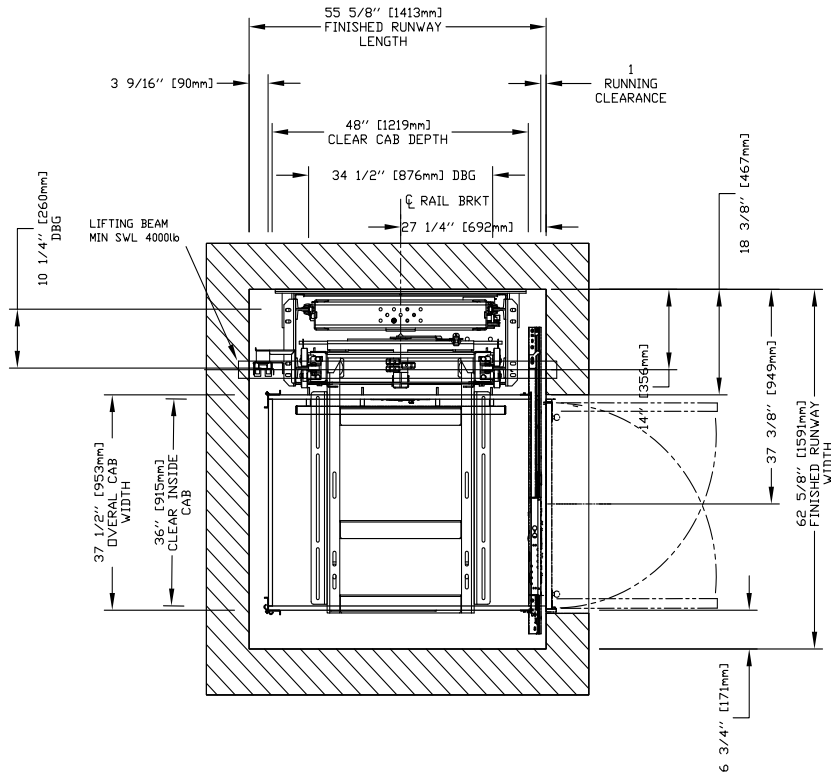

**IMPORTANT**

Finished hoistway dimensions must include the drywall. Determine the fire rating of the hoistway and the type and layers of sheet rock. Build only from the final shop drawings specific to your installation.

### 36" x 48" Type 1R Cab, Auto Slim (29.5") Doors

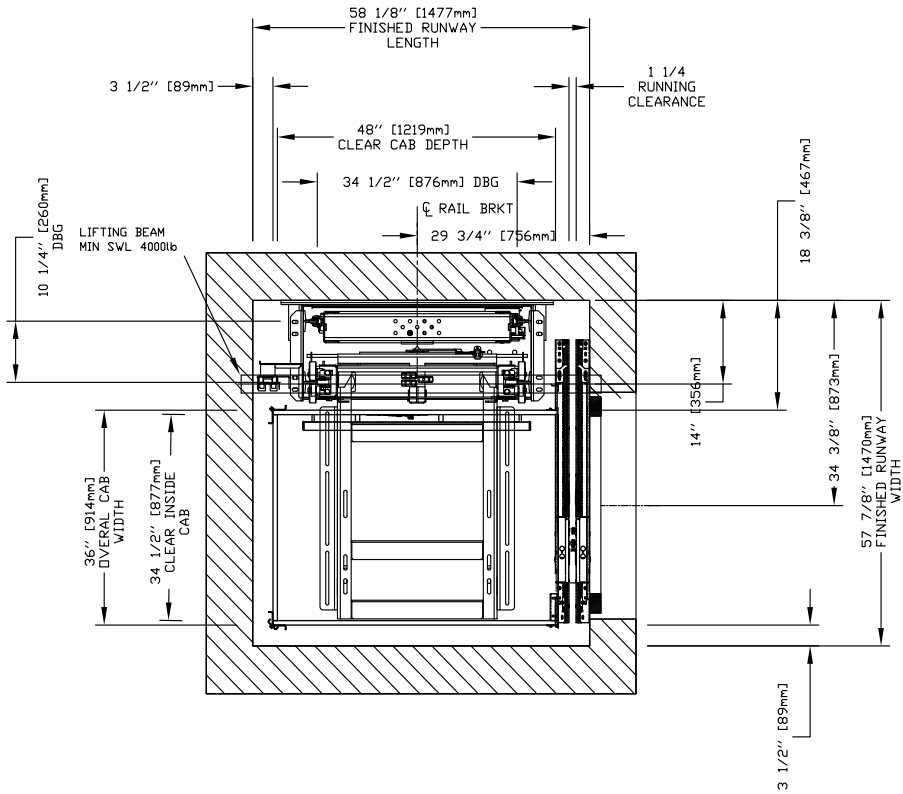

### 36" x 48" Type 1R Cab, Auto Slim (29.5") Doors + Swing

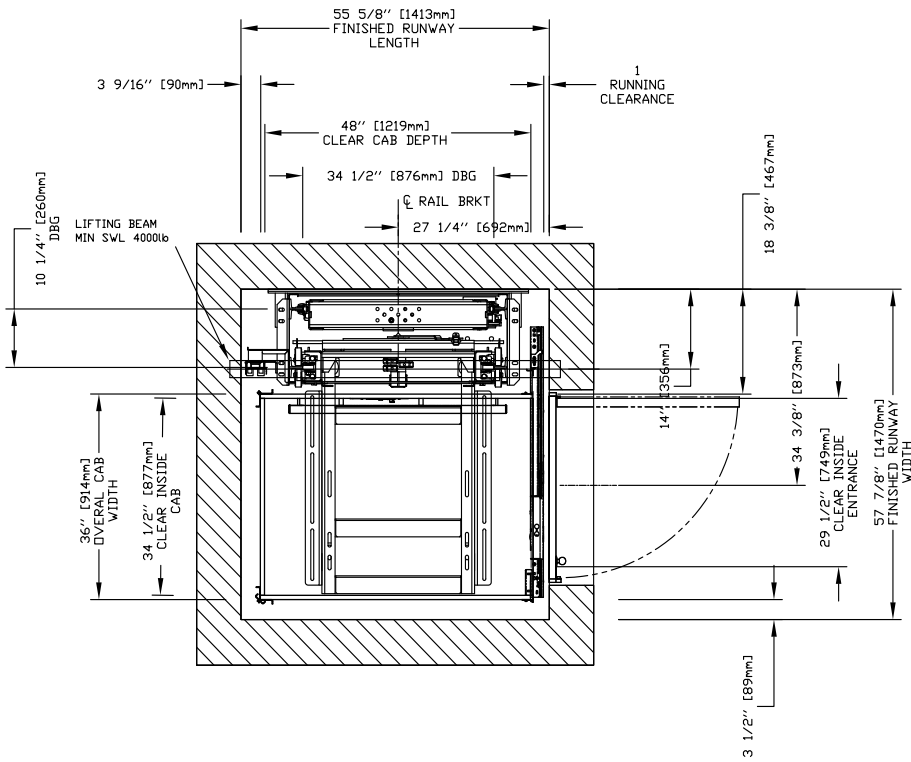

**IMPORTANT**

Finished hoistway dimensions must include the drywall. Determine the fire rating of the hoistway and the type and layers of sheet rock. Build only from the final shop drawings specific to your installation.

## 36" x 48" Type 2 Cab, Auto Slim (35.5") Doors

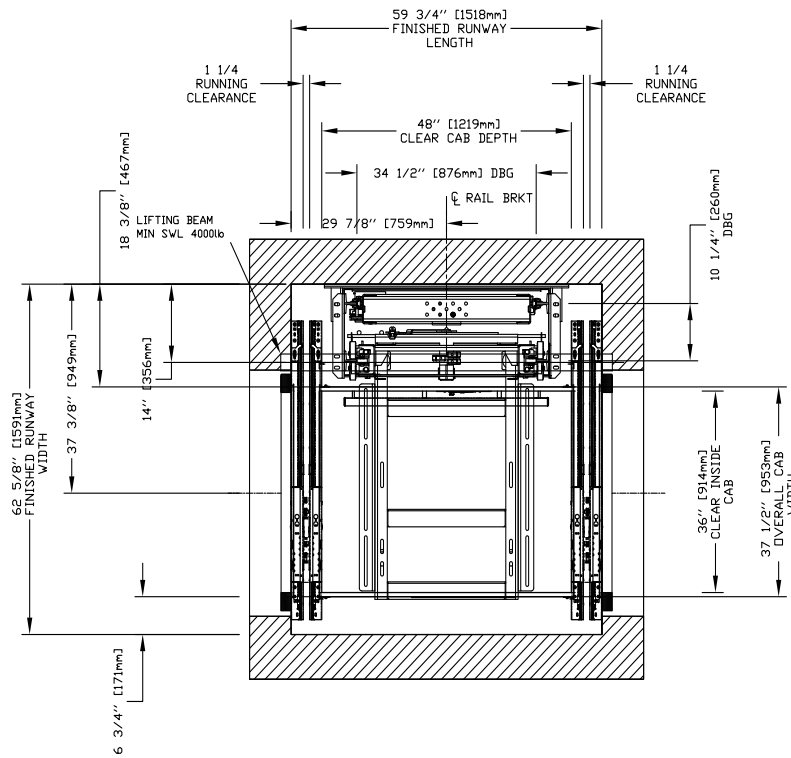

## 36" x 48" Type 2 Cab, Auto Slim (35.5") Doors + Swing

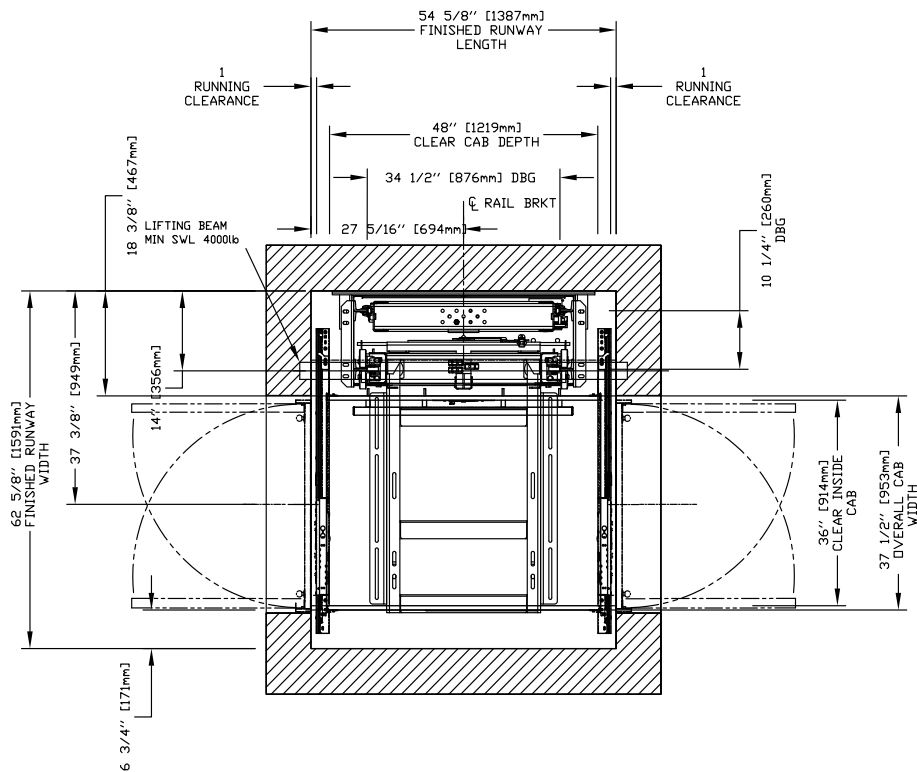

### IMPORTANT

Finished hoistway dimensions must include the drywall. Determine the fire rating of the hoistway and the type and layers of sheet rock. Build only from the final shop drawings specific to your installation.

### 36" x 48" Type 2 Cab, Auto Slim (29.5") Doors

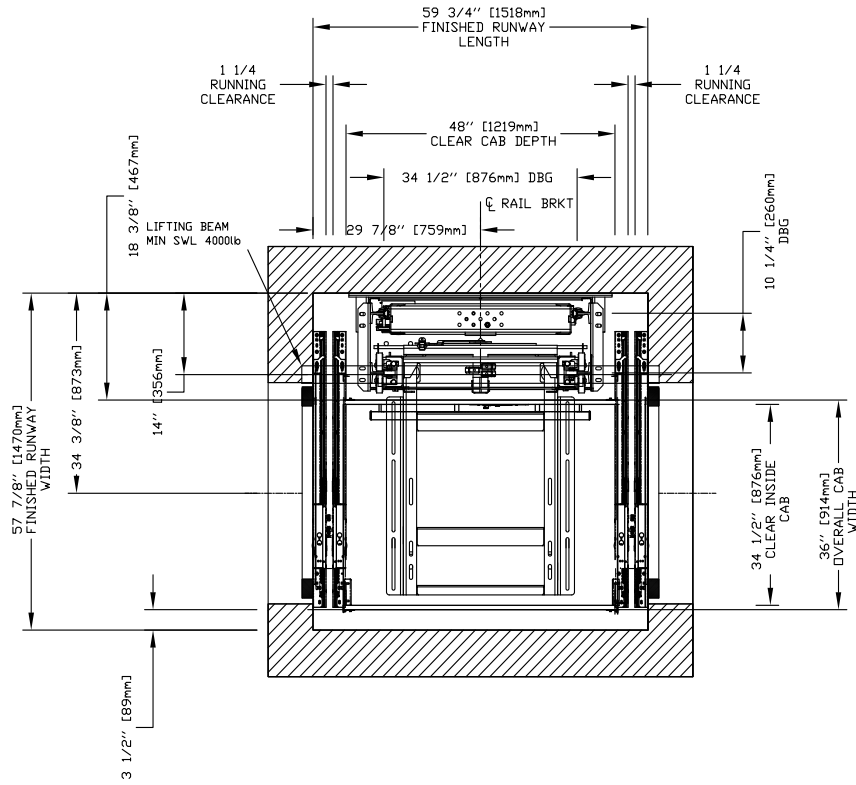

### 36" x 48" Type 2 Cab, Auto Slim (29.5") Doors + Swing

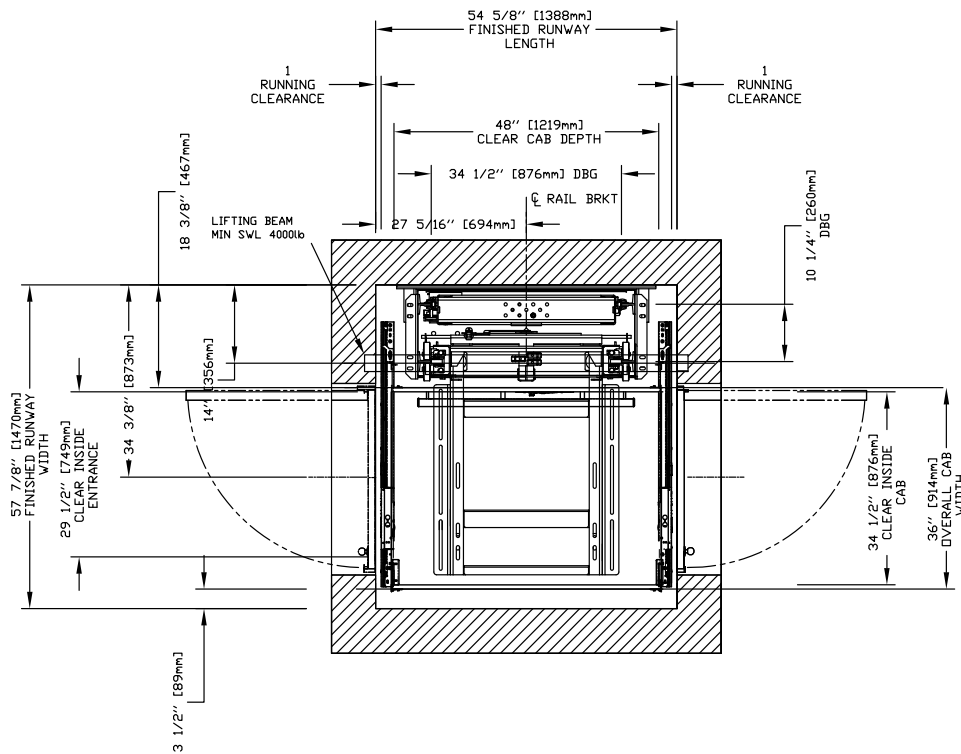

**IMPORTANT**

Finished hoistway dimensions must include the drywall. Determine the fire rating of the hoistway and the type and layers of sheet rock. Build only from the final shop drawings specific to your installation.

### 36" x 48" Type 5 Cab, Auto Slim (29.5") Doors

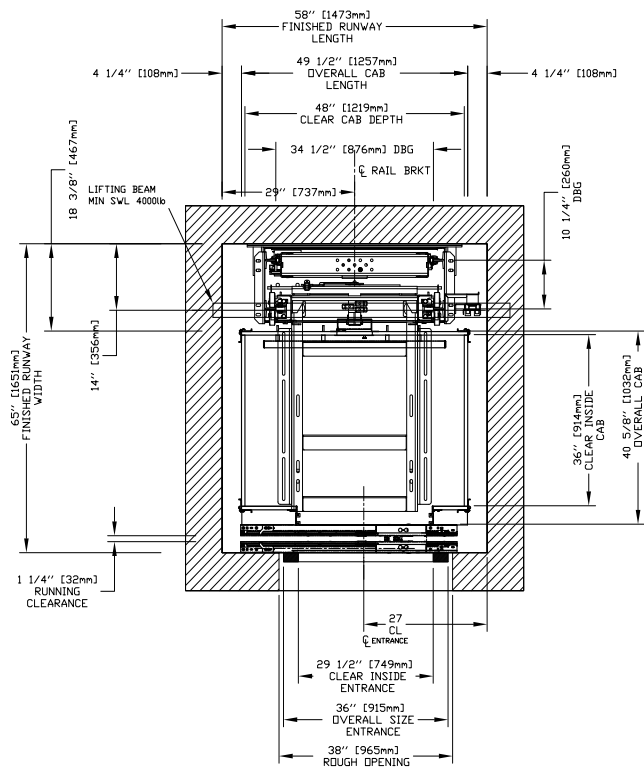

### 36" x 48" Type 5 Cab, Auto Slim (29.5") Doors + Swing

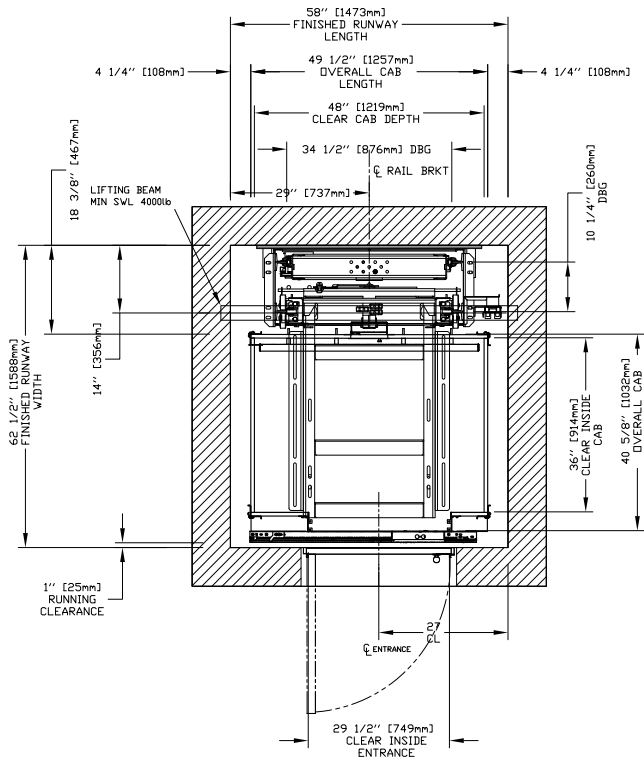

**IMPORTANT**

Finished hoistway dimensions must include the drywall. Determine the fire rating of the hoistway and the type and layers of sheet rock. Build only from the final shop drawings specific to your installation.

### 36" x 54" Type 1L Cab, Auto Slim (35.5") Doors

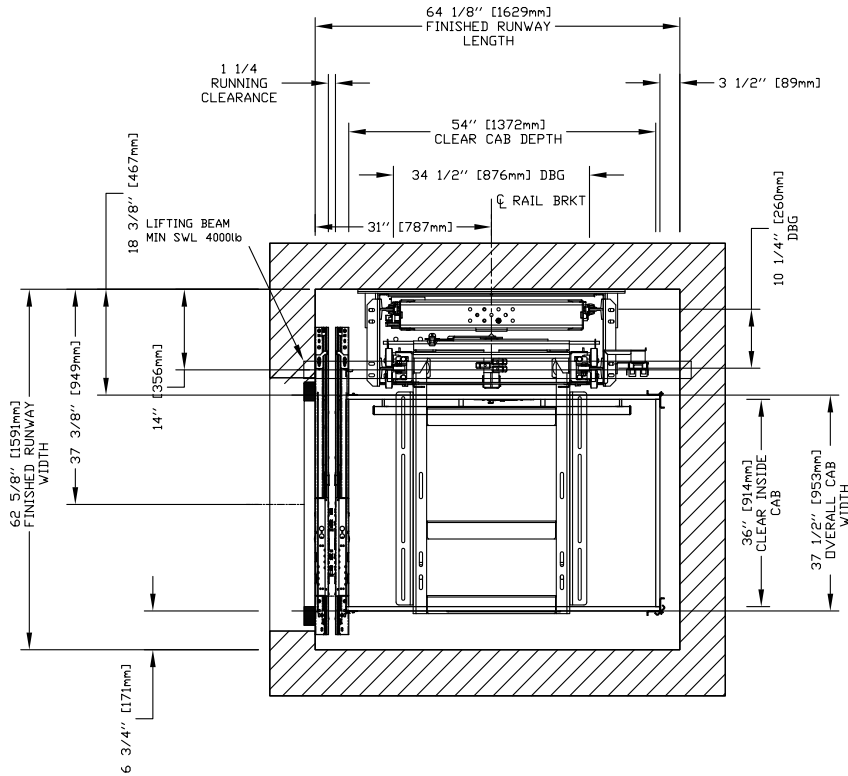

### 36" x 54" Type 1L Cab, Auto Slim (35.5") Doors + Swing

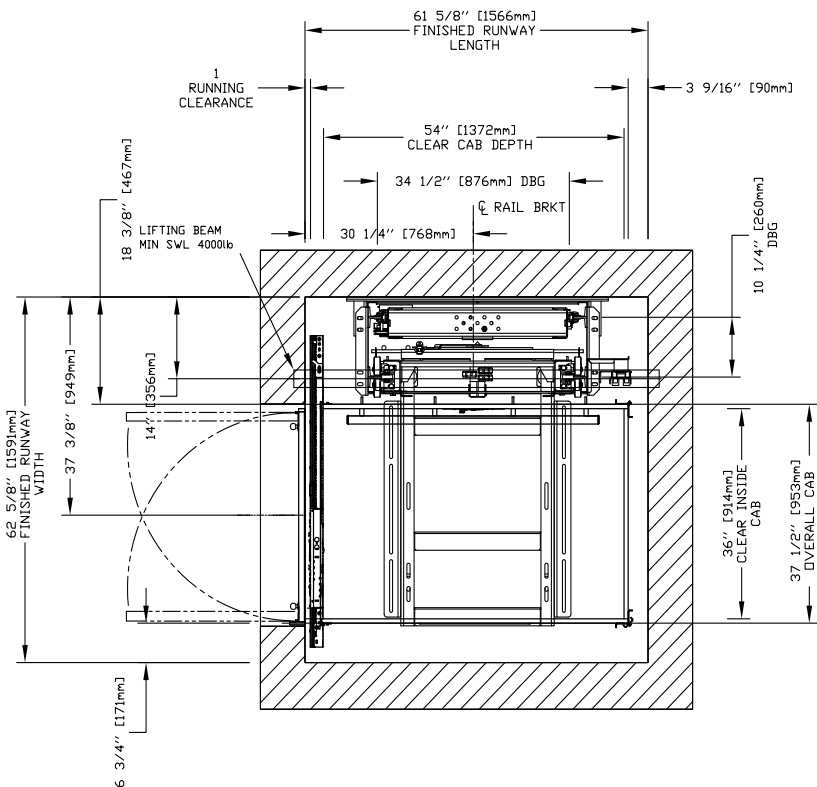

**IMPORTANT**

Finished hoistway dimensions must include the drywall. Determine the fire rating of the hoistway and the type and layers of sheet rock. Build only from the final shop drawings specific to your installation.

### 36" x 54" Type 1L Cab, Auto Slim (29.5") Doors

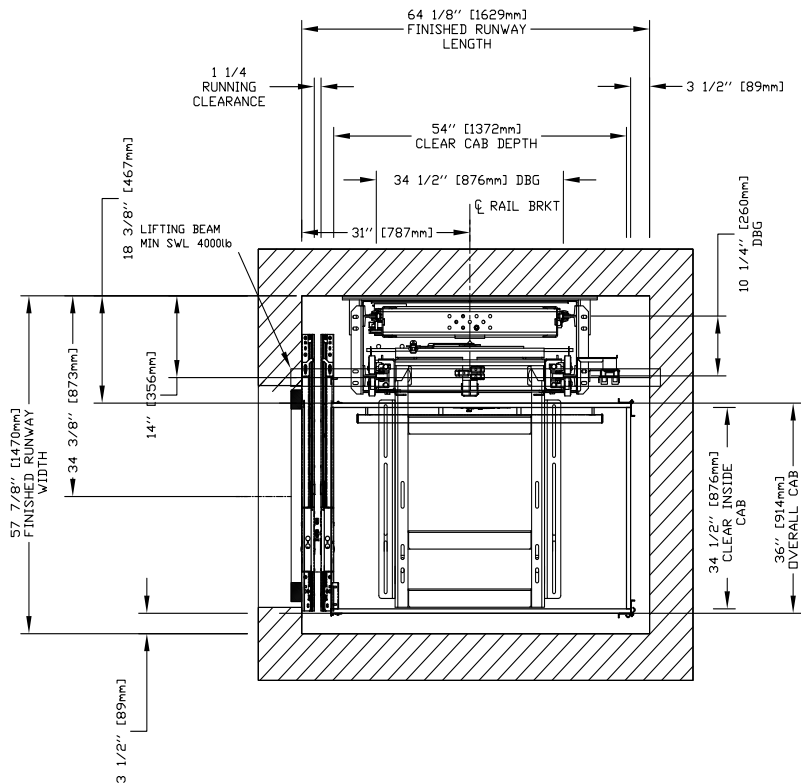

### 36" x 54" Type 1L Cab, Auto Slim (29.5") Doors + Swing

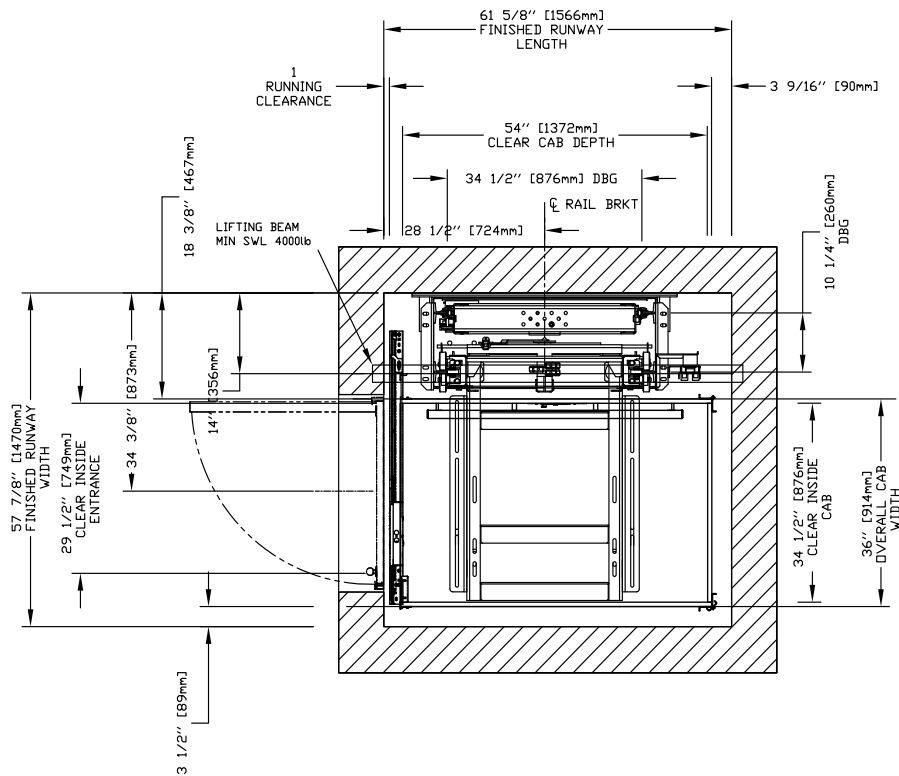

**IMPORTANT**

Finished hoistway dimensions must include the drywall. Determine the fire rating of the hoistway and the type and layers of sheet rock. Build only from the final shop drawings specific to your installation.

### 36" x 54" Type 1R Cab, Auto Slim (35.5") Doors

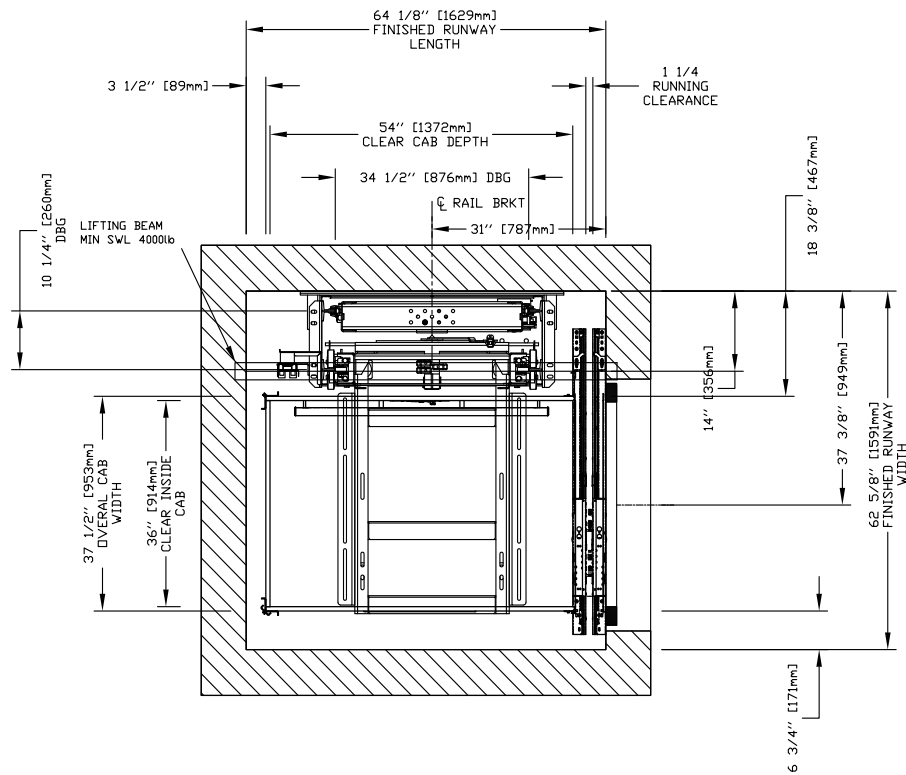

### 36" x 54" Type 1R Cab, Auto Slim (35.5") Doors + Swing

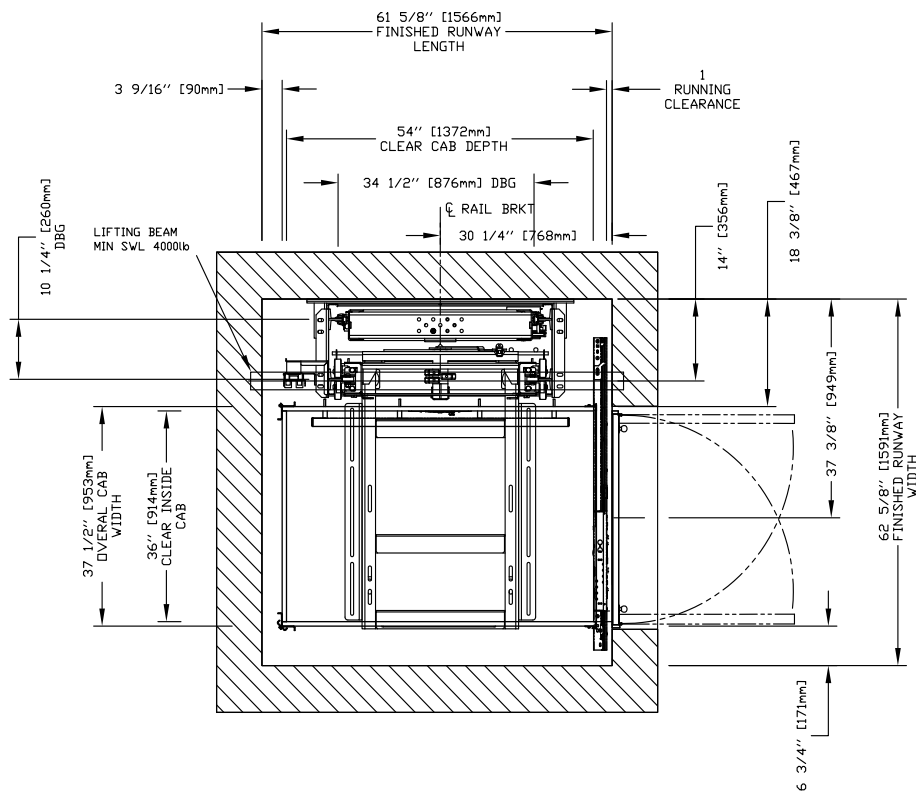

**IMPORTANT**

Finished hoistway dimensions must include the drywall. Determine the fire rating of the hoistway and the type and layers of sheet rock. Build only from the final shop drawings specific to your installation.



### 36" x 54" Type 1R Cab, Auto Slim (29.5") Doors

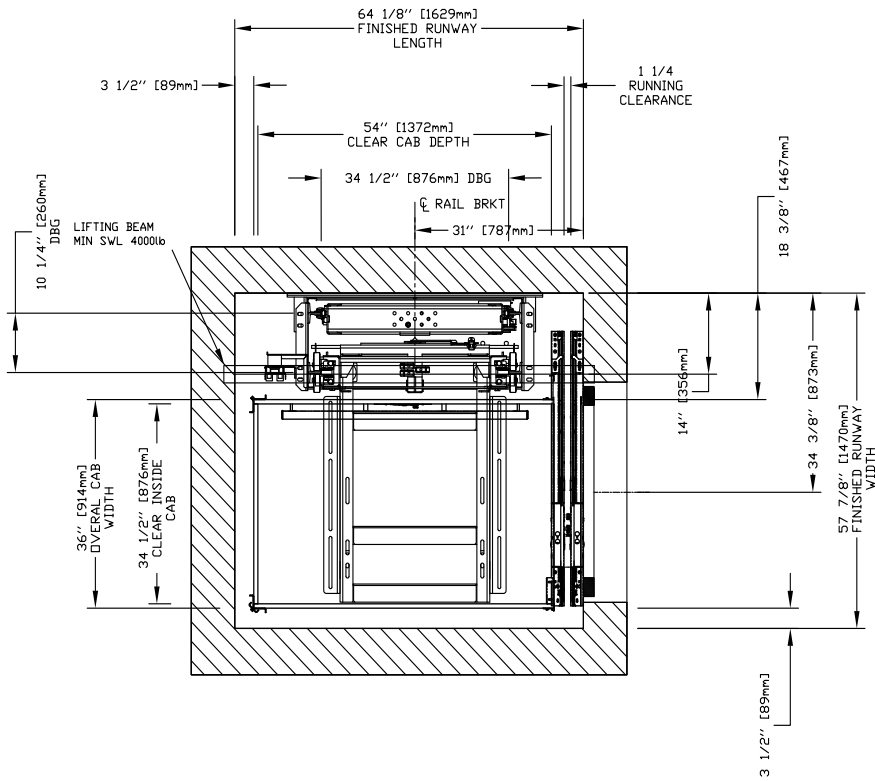

### 36" x 54" Type 1R Cab, Auto Slim (29.5") Doors + Swing

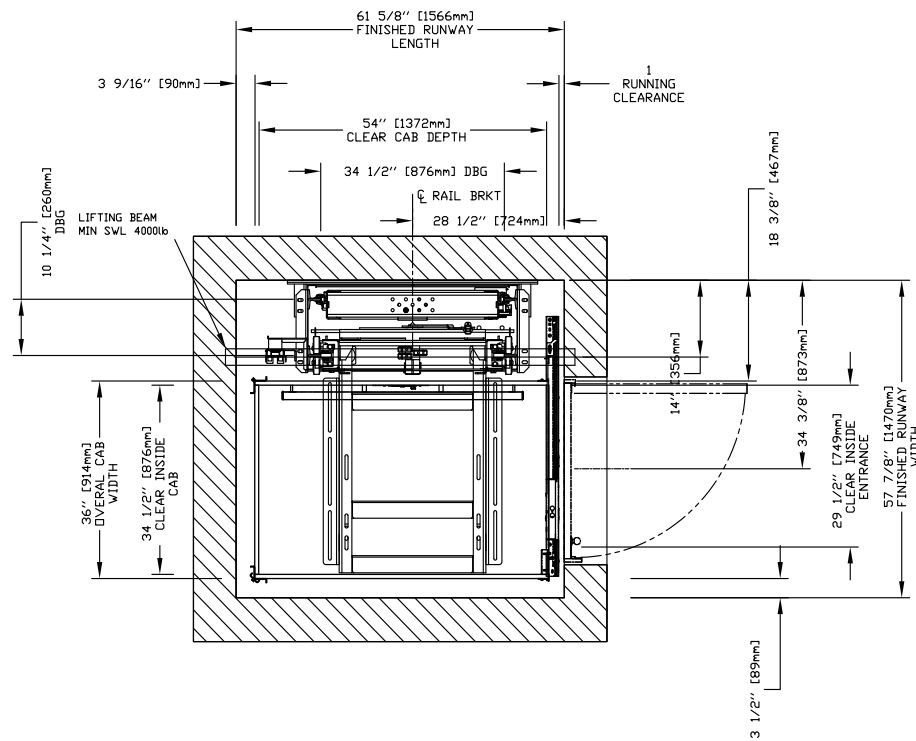

**IMPORTANT**

Finished hoistway dimensions must include the drywall. Determine the fire rating of the hoistway and the type and layers of sheet rock. Build only from the final shop drawings specific to your installation.

### 36" x 54" Type 2 Cab, Auto Slim (35.5") Doors

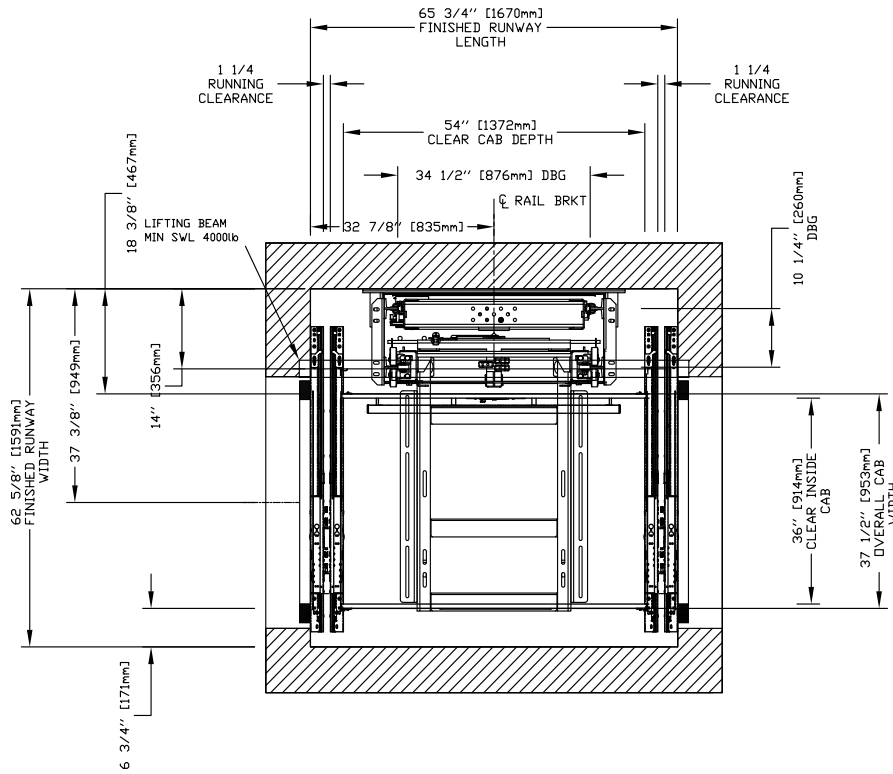

### 36" x 54" Type 2 Cab, Auto Slim (35.5") Doors + Swing

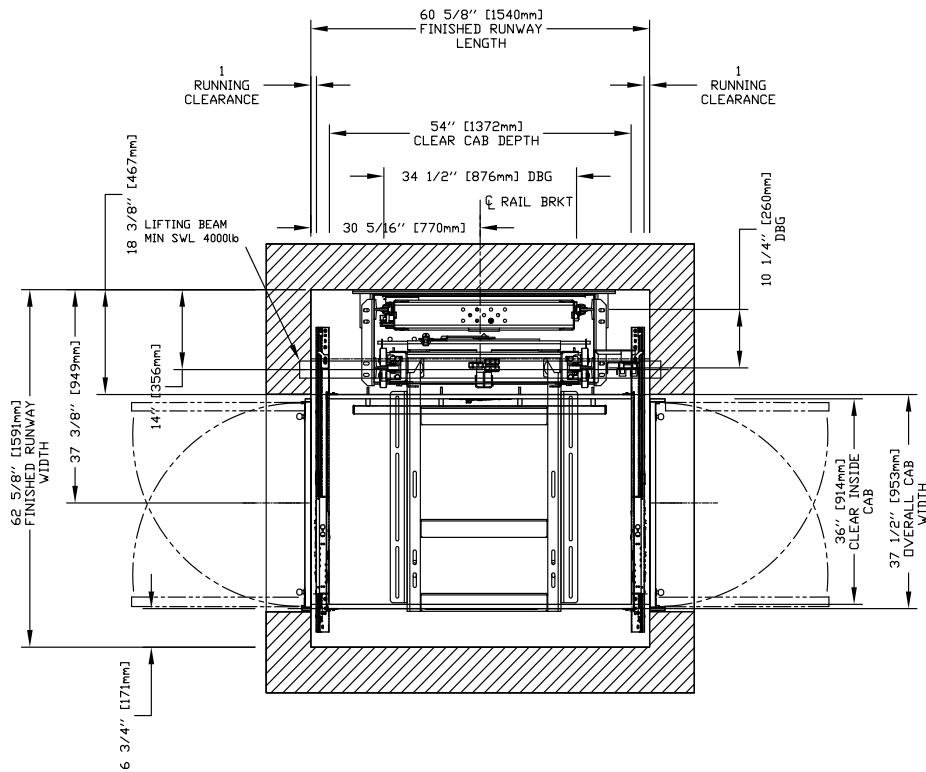

**IMPORTANT**

Finished hoistway dimensions must include the drywall. Determine the fire rating of the hoistway and the type and layers of sheet rock. Build only from the final shop drawings specific to your installation.

### 36" x 54" Type 2 Cab, Auto Slim (29.5") Doors

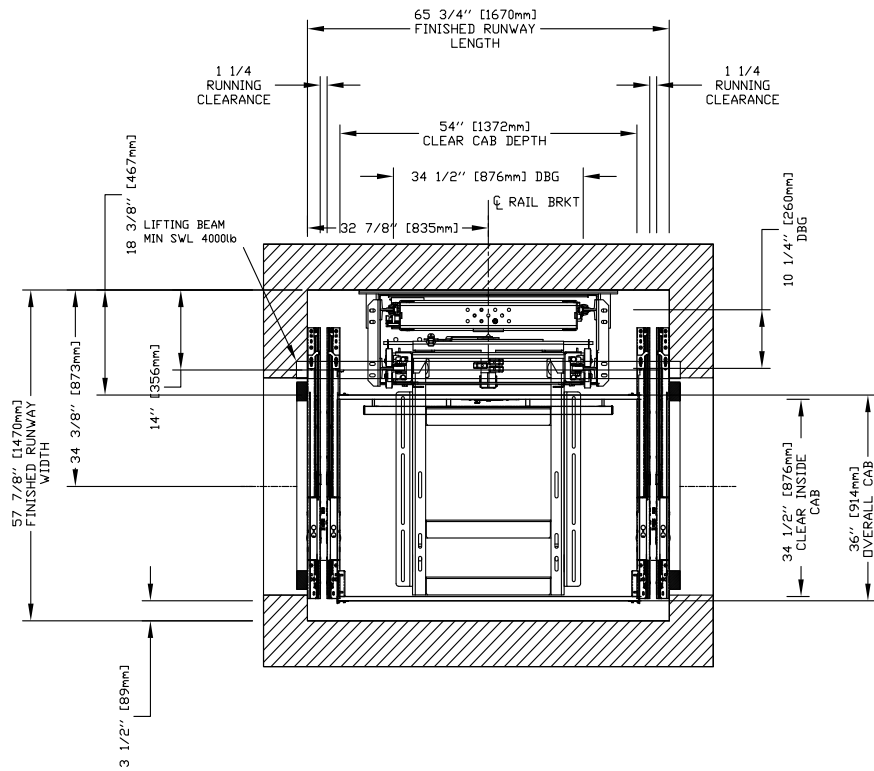

### 36" x 54" Type 2 Cab, Auto Slim (29.5") Doors + Swing

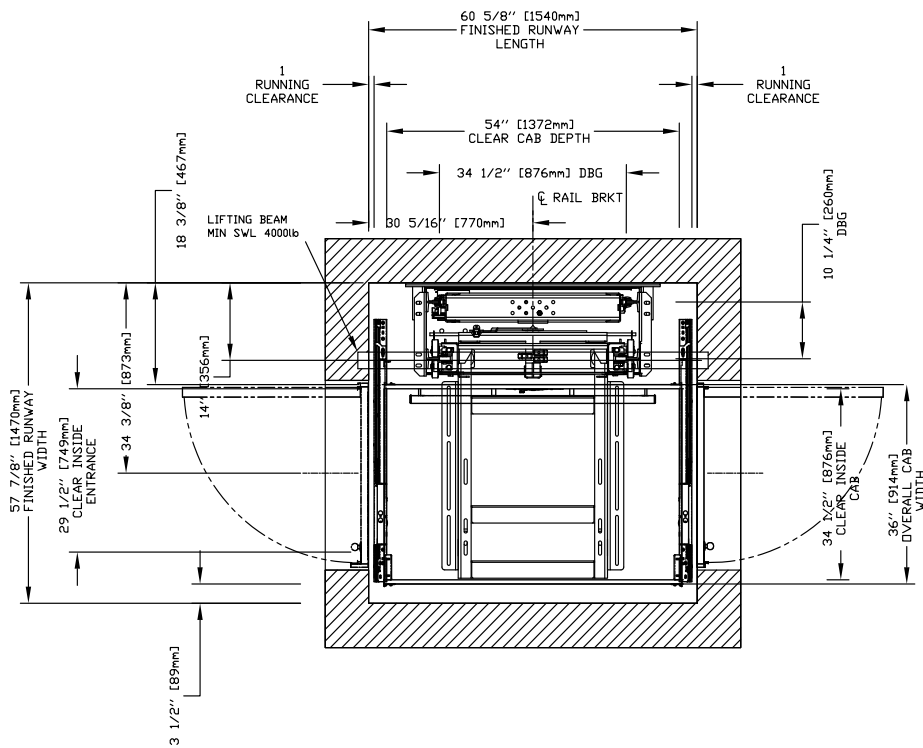

**IMPORTANT**

Finished hoistway dimensions must include the drywall. Determine the fire rating of the hoistway and the type and layers of sheet rock. Build only from the final shop drawings specific to your installation.

### 36" x 54" Type 3 Cab, Auto Slim (35.5") Doors

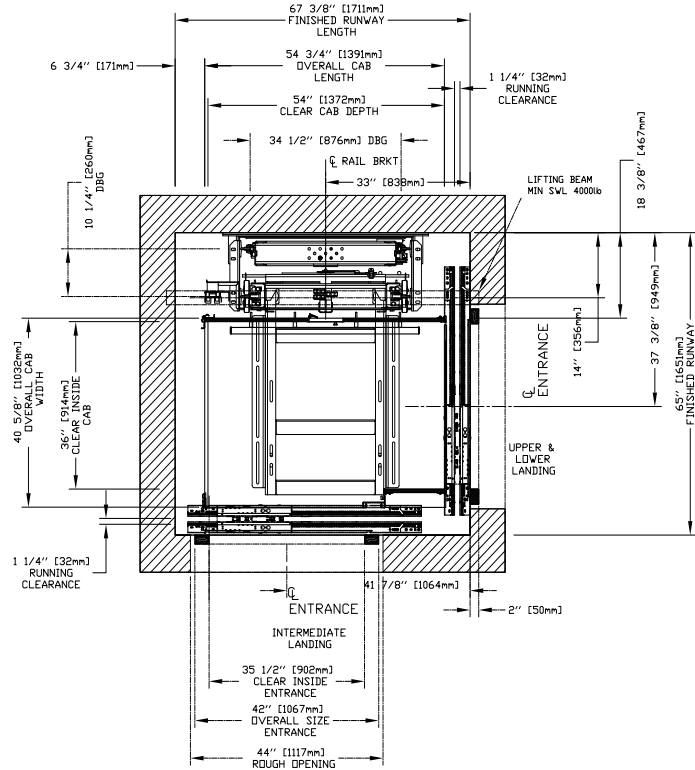

### 36" x 54" Type 3 Cab, Auto Slim (35.5") Doors + Swing

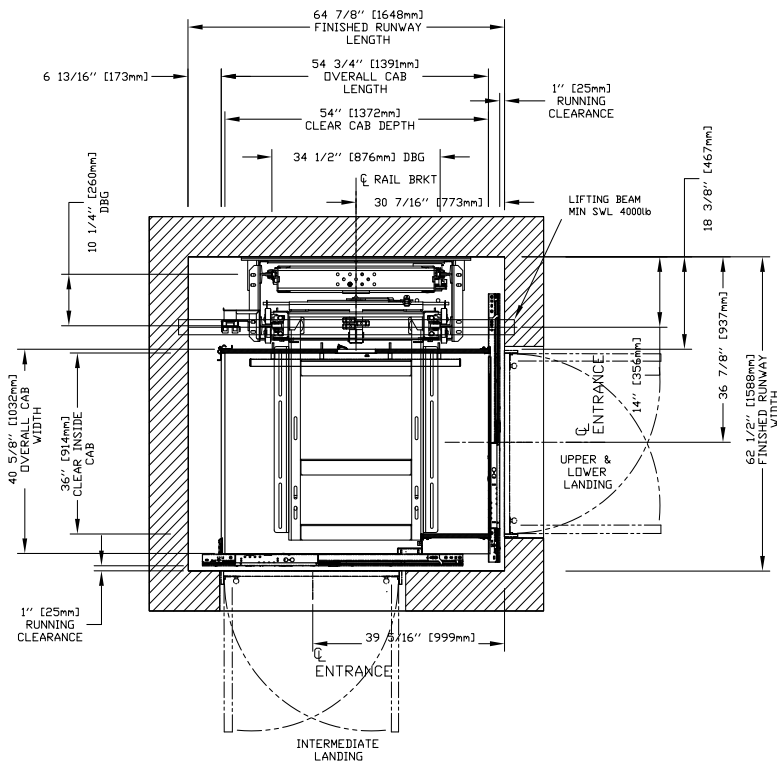

**IMPORTANT**

Finished hoistway dimensions must include the drywall. Determine the fire rating of the hoistway and the type and layers of sheet rock. Build only from the final shop drawings specific to your installation.

### 36" x 54" Type 3 Cab, Auto Slim (29.5") Doors

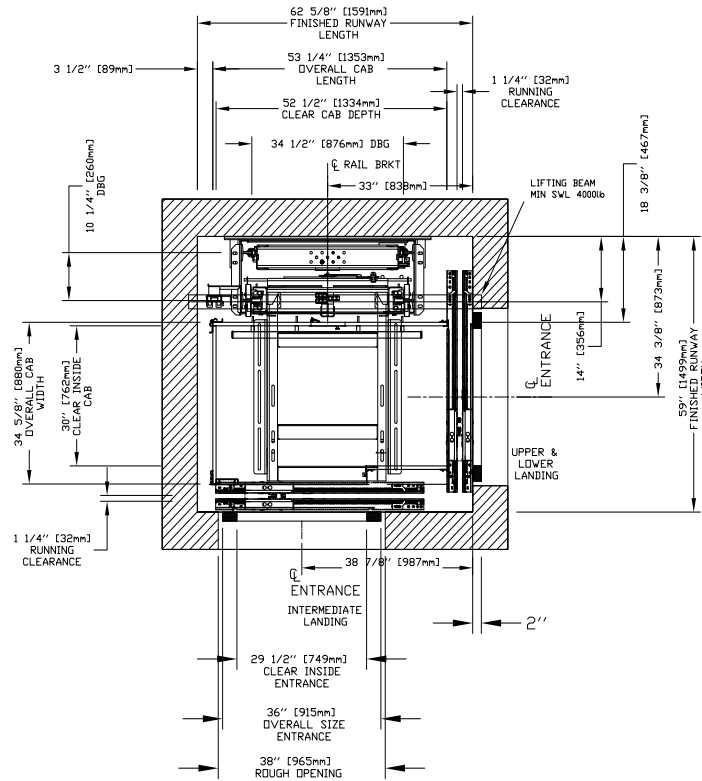

### 36" x 54" Type 3 Cab, Auto Slim (29.5") Doors + Swing

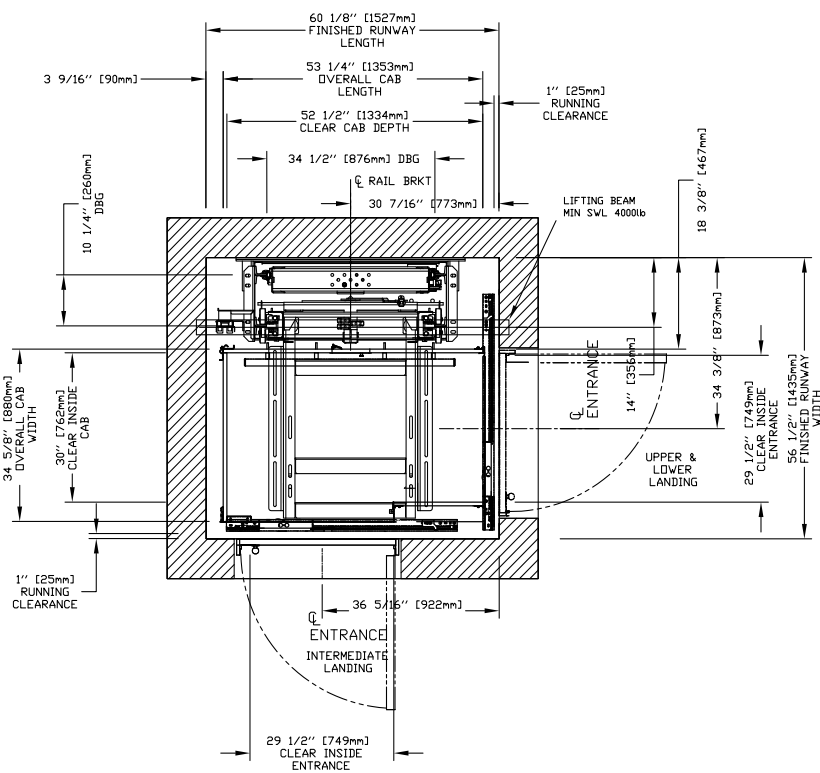

**IMPORTANT**

Finished hoistway dimensions must include the drywall. Determine the fire rating of the hoistway and the type and layers of sheet rock. Build only from the final shop drawings specific to your installation.

### 36" x 54" Type 4 Cab, Auto Slim (35.5") Doors

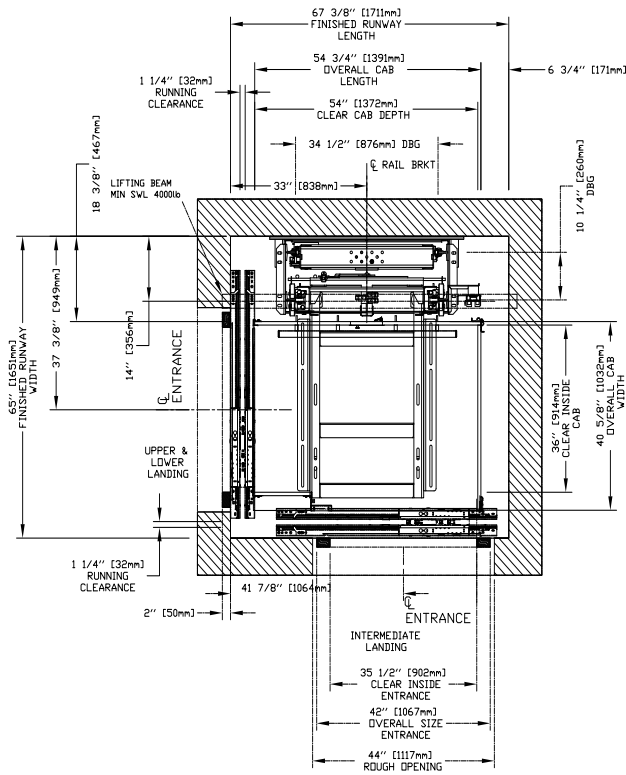

### 36" x 54" Type 4 Cab, Auto Slim (35.5") Doors + Swing

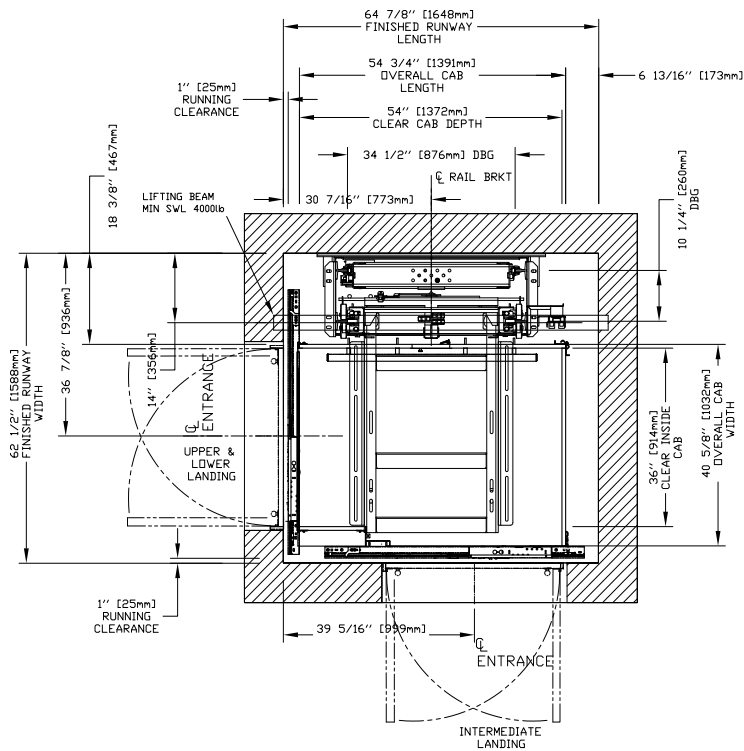

**IMPORTANT**

Finished hoistway dimensions must include the drywall. Determine the fire rating of the hoistway and the type and layers of sheet rock. Build only from the final shop drawings specific to your installation.

### 36" x 54" Type 4 Cab, Auto Slim (29.5") Doors

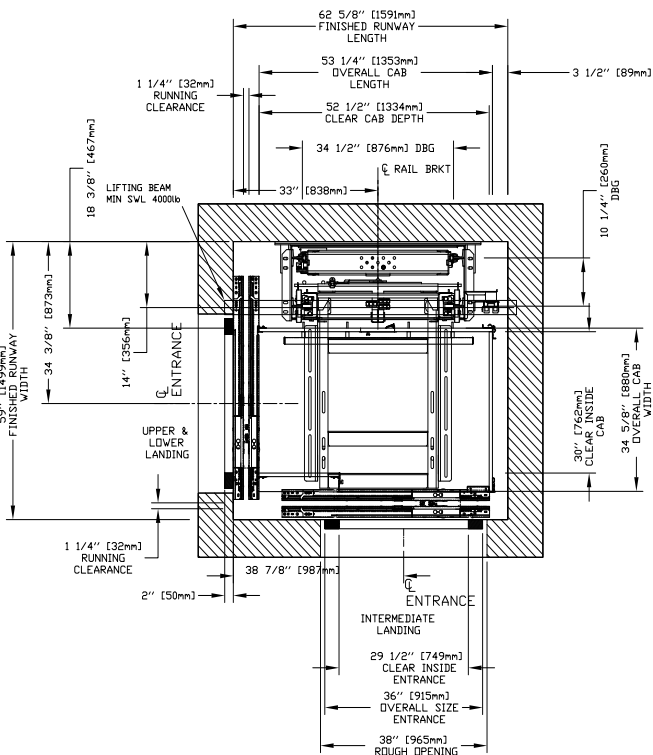

### 36" x 54" Type 4 Cab, Auto Slim (29.5") Doors + Swing

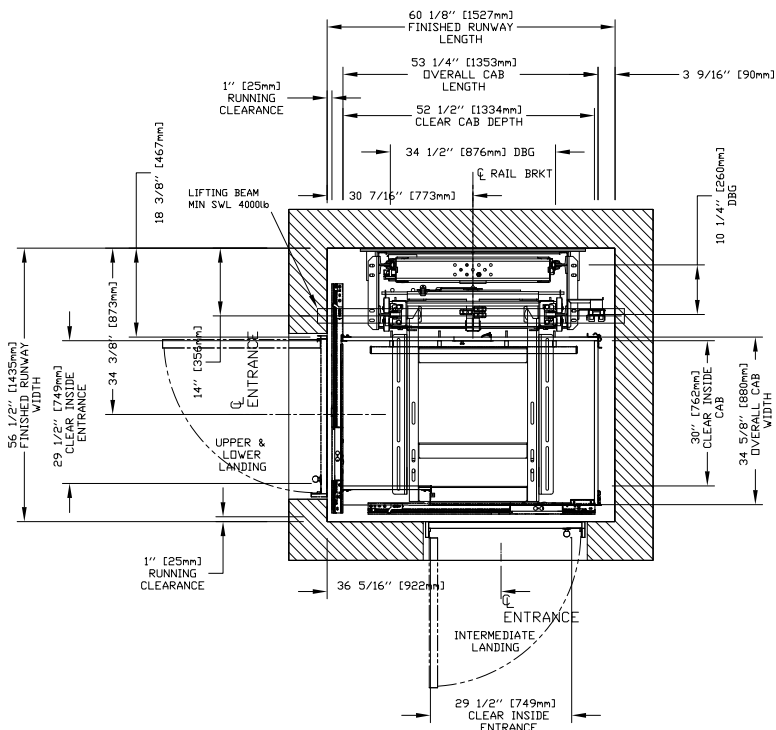

**IMPORTANT**

Finished hoistway dimensions must include the drywall. Determine the fire rating of the hoistway and the type and layers of sheet rock. Build only from the final shop drawings specific to your installation.

### 36" x 54" Type 5 Cab, Auto Slim (35.5") Doors

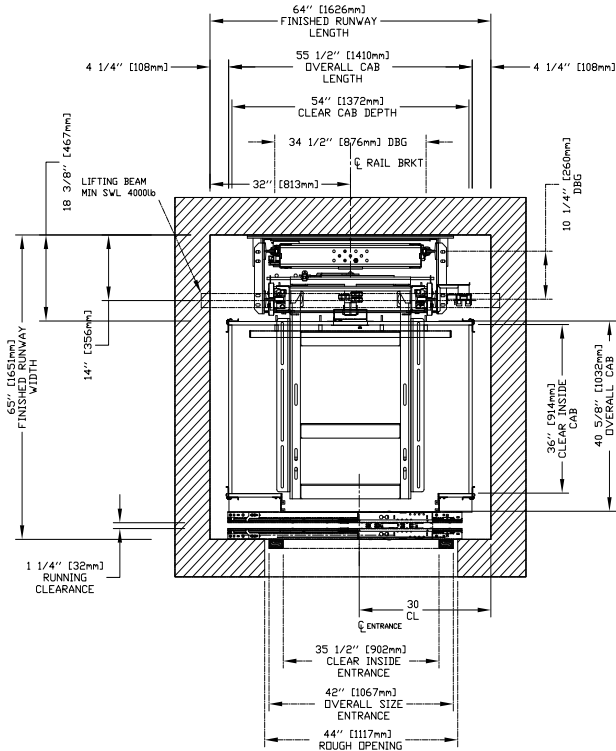

### 36" x 54" Type 5 Cab, Auto Slim (35.5") Doors + Swing

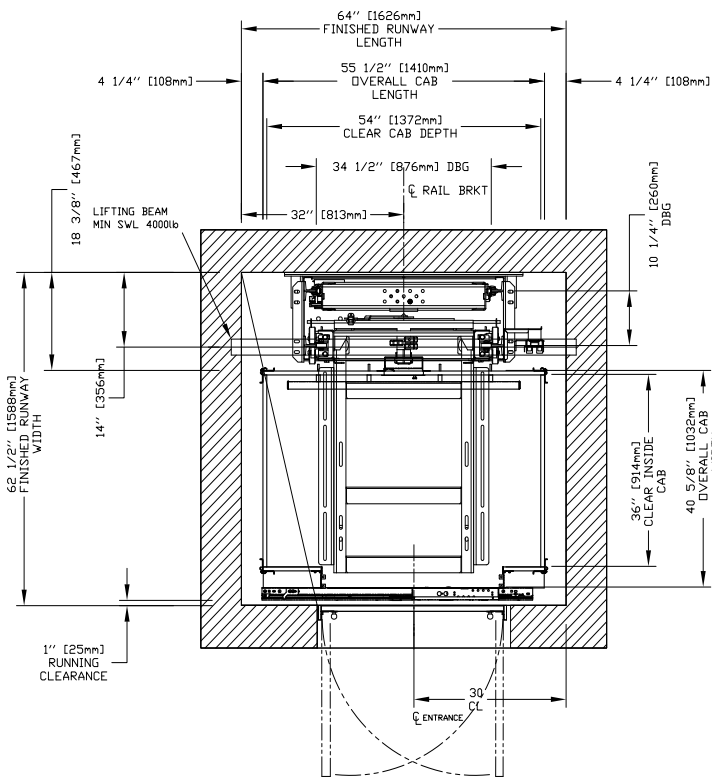

**IMPORTANT**

Finished hoistway dimensions must include the drywall. Determine the fire rating of the hoistway and the type and layers of sheet rock. Build only from the final shop drawings specific to your installation.



### 36" x 54" Type 5 Cab, Auto Slim (29.5") Doors

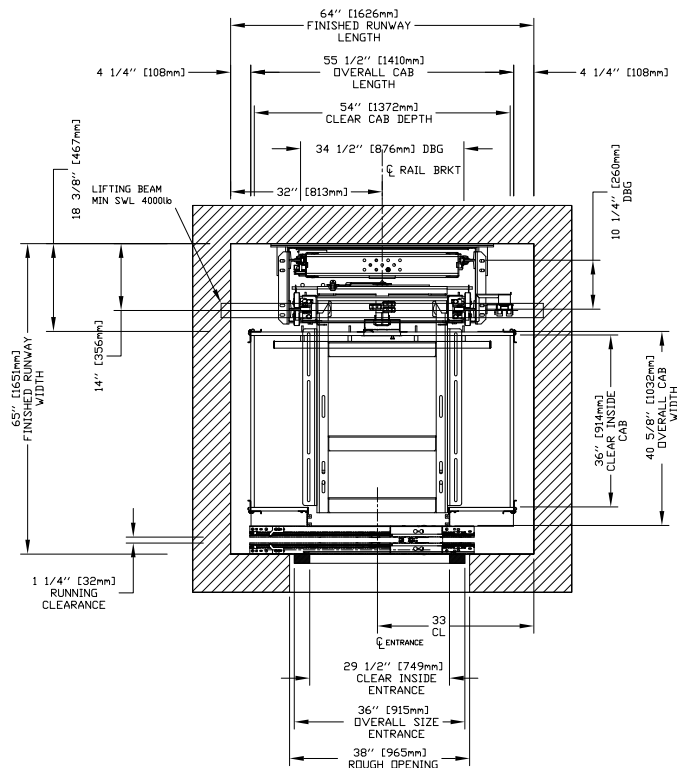

### 36" x 54" Type 5 Cab, Auto Slim (29.5") Doors + Swing

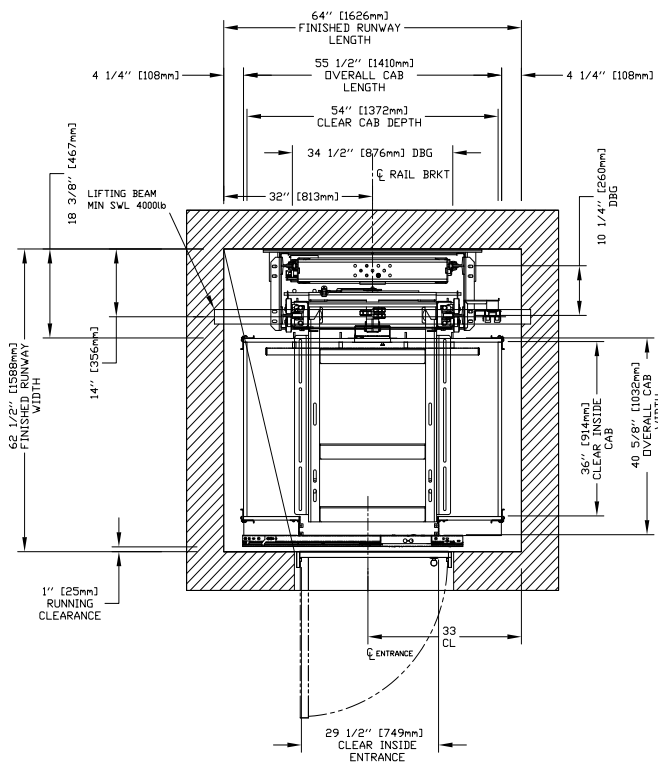

**IMPORTANT**

Finished hoistway dimensions must include the drywall. Determine the fire rating of the hoistway and the type and layers of sheet rock. Build only from the final shop drawings specific to your installation.

### 36" x 60" Type 1L Cab, Auto Slim (35.5") Doors

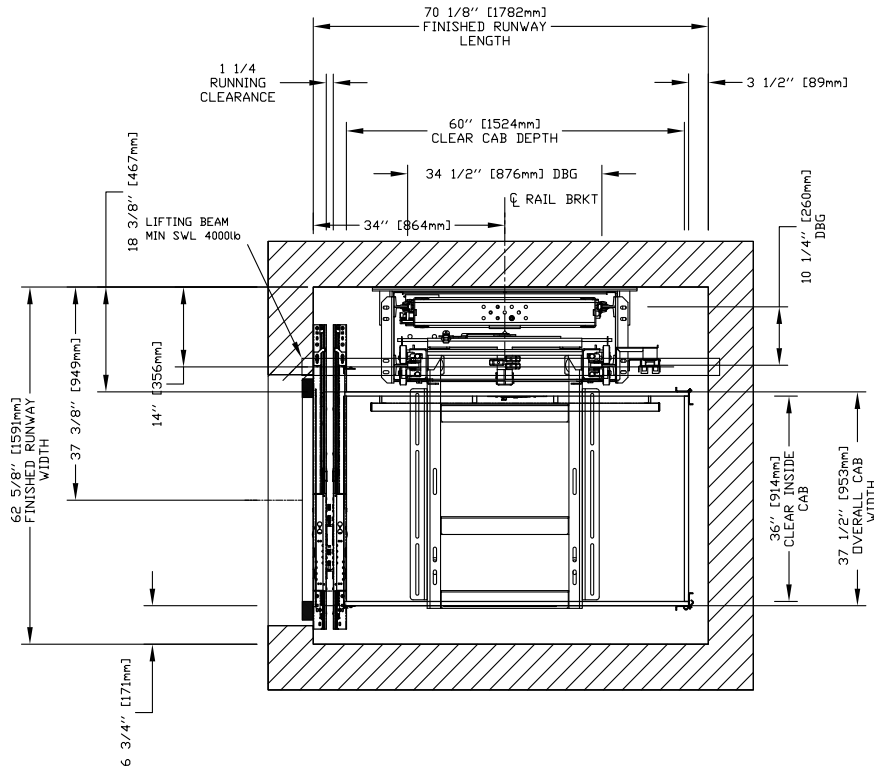

### 36" x 60" Type 1L Cab, Auto Slim (35.5") Doors + Swing

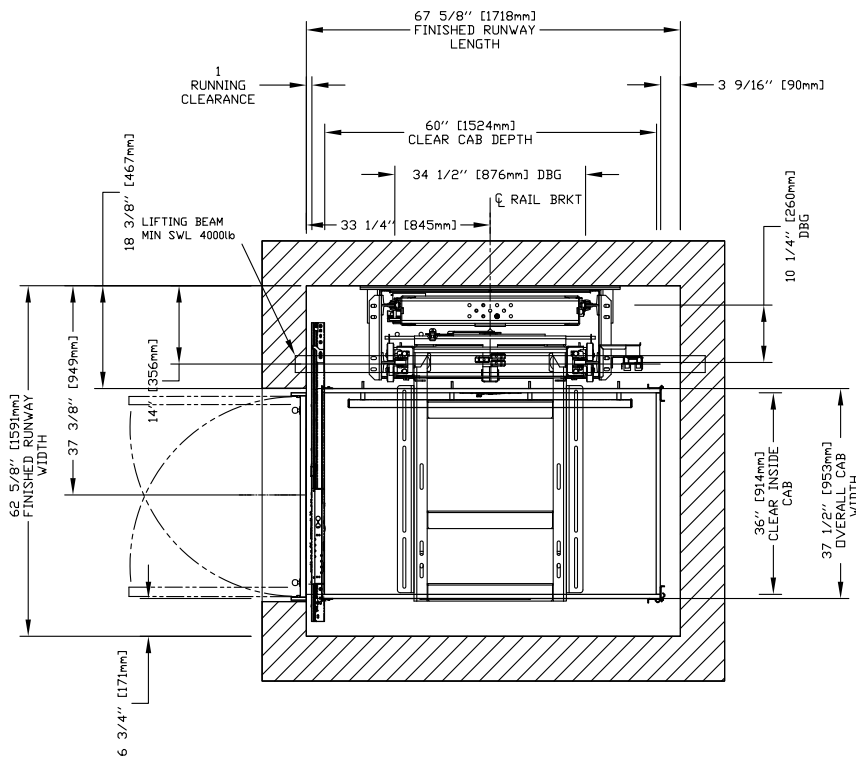

**IMPORTANT**

Finished hoistway dimensions must include the drywall. Determine the fire rating of the hoistway and the type and layers of sheet rock. Build only from the final shop drawings specific to your installation.

### 36" x 60" Type 1L Cab, Auto Slim (29.5") Doors

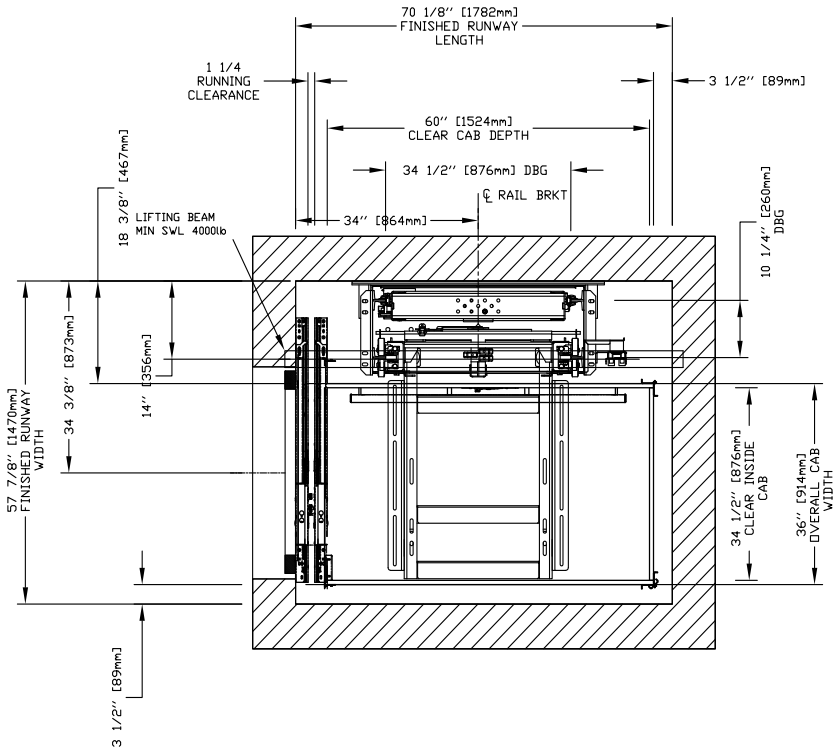

### 36" x 60" Type 1L Cab, Auto Slim (29.5") Doors + Swing

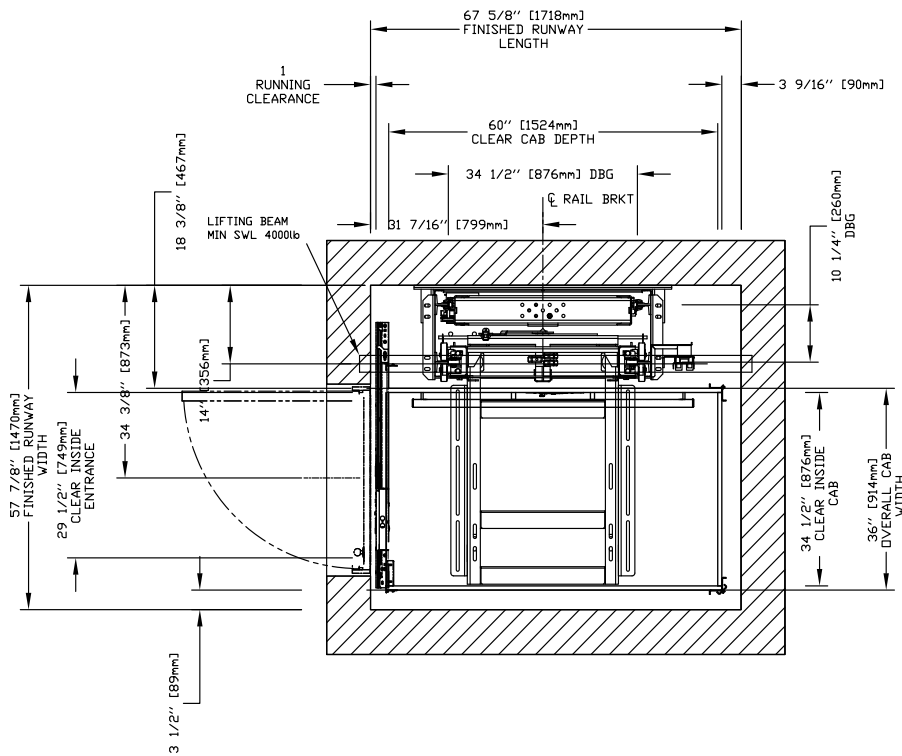

**IMPORTANT**

Finished hoistway dimensions must include the drywall. Determine the fire rating of the hoistway and the type and layers of sheet rock. Build only from the final shop drawings specific to your installation.

### 36" x 60" Type 1R Cab, Auto Slim (35.5") Doors

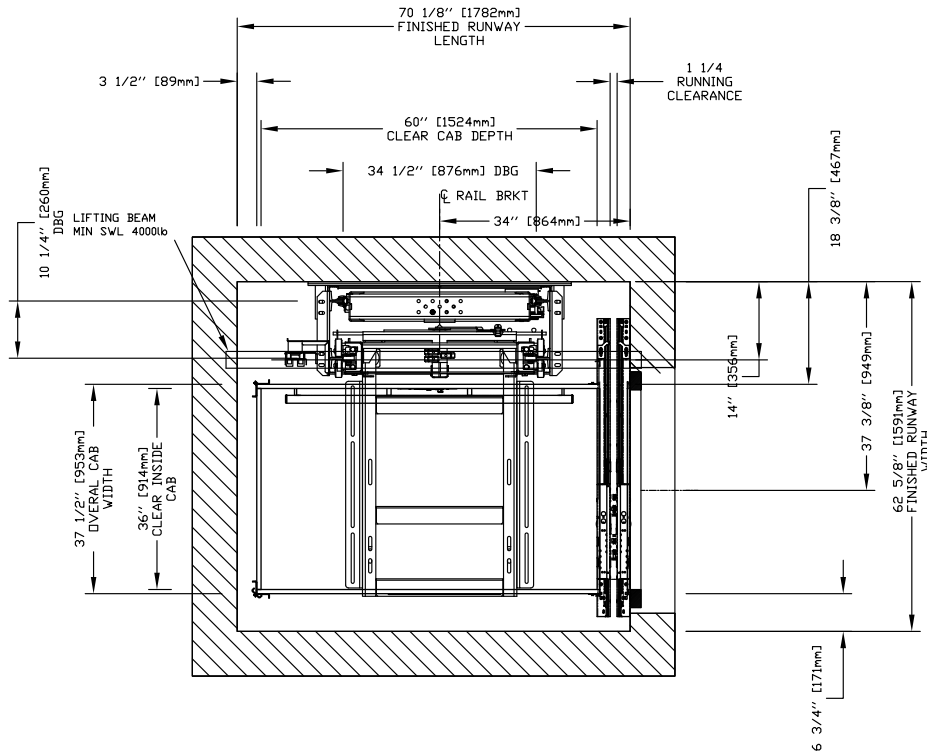

### 36" x 60" Type 1R Cab, Auto Slim (35.5") Doors + Swing

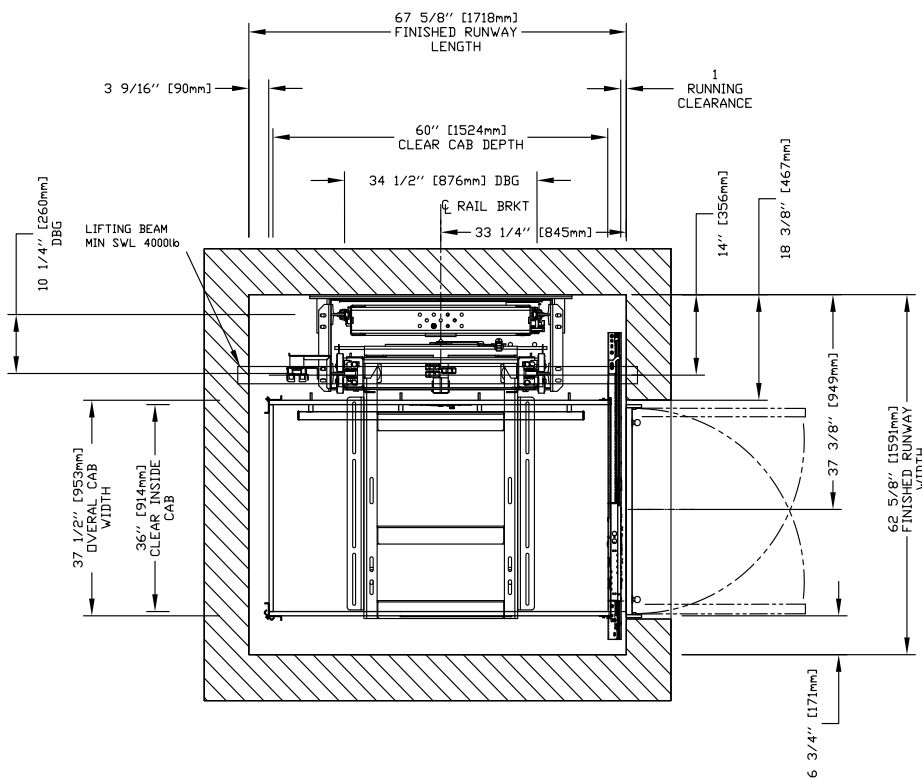

**IMPORTANT**

Finished hoistway dimensions must include the drywall. Determine the fire rating of the hoistway and the type and layers of sheet rock. Build only from the final shop drawings specific to your installation.

### 36" x 60" Type 1R Cab, Auto Slim (29.5") Doors

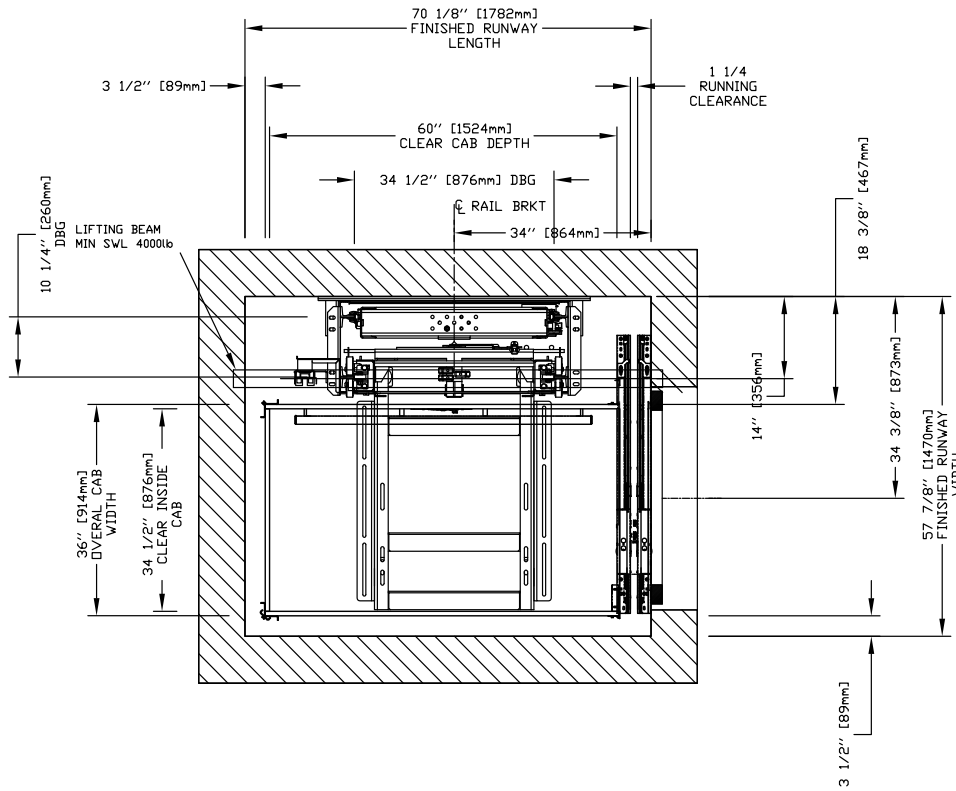

### 36" x 60" Type 1R Cab, Auto Slim (29.5") Doors + Swing

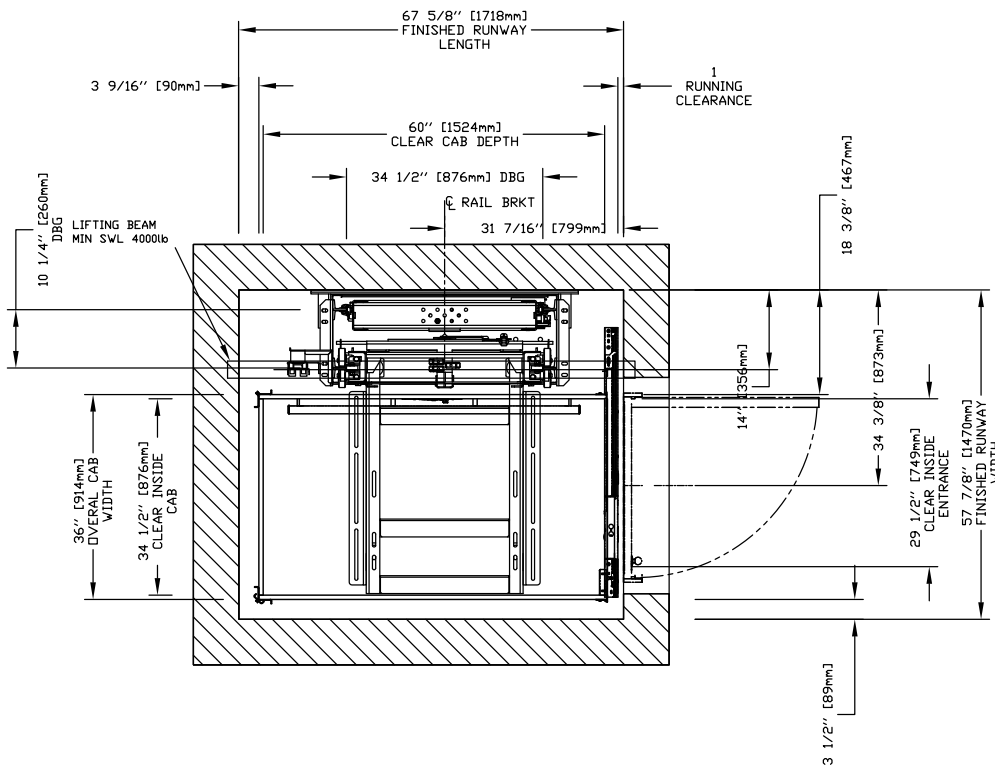

**IMPORTANT**

Finished hoistway dimensions must include the drywall. Determine the fire rating of the hoistway and the type and layers of sheet rock. Build only from the final shop drawings specific to your installation.

### 36" x 60" Type 2 Cab, Auto Slim (35.5") Doors

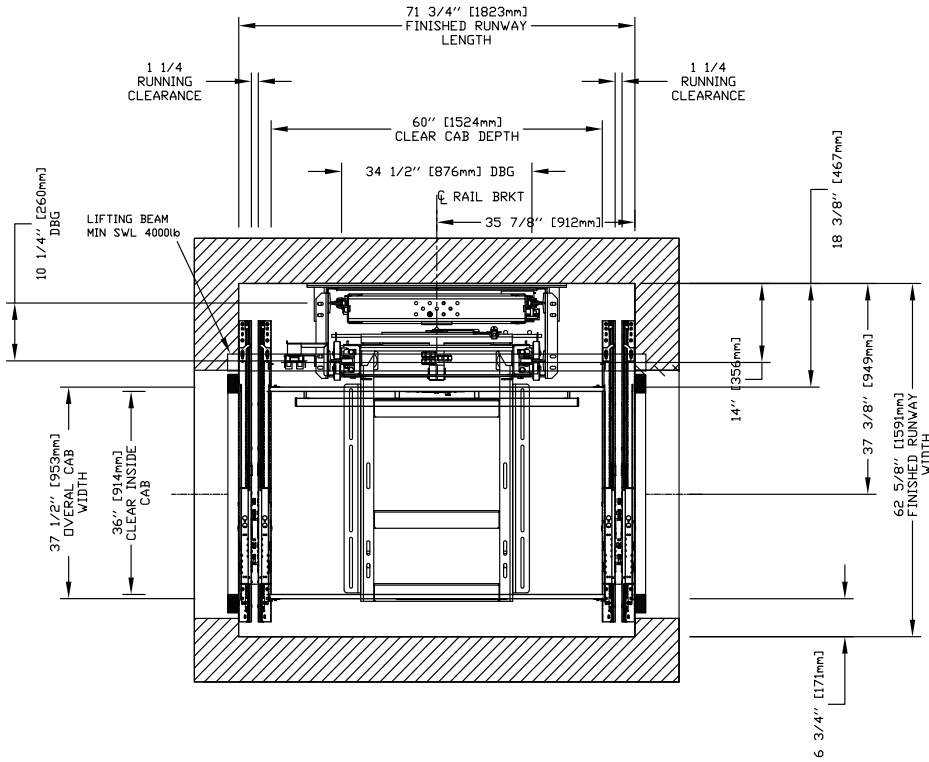

### 36" x 60" Type 2 Cab, Auto Slim (35.5") Doors + Swing

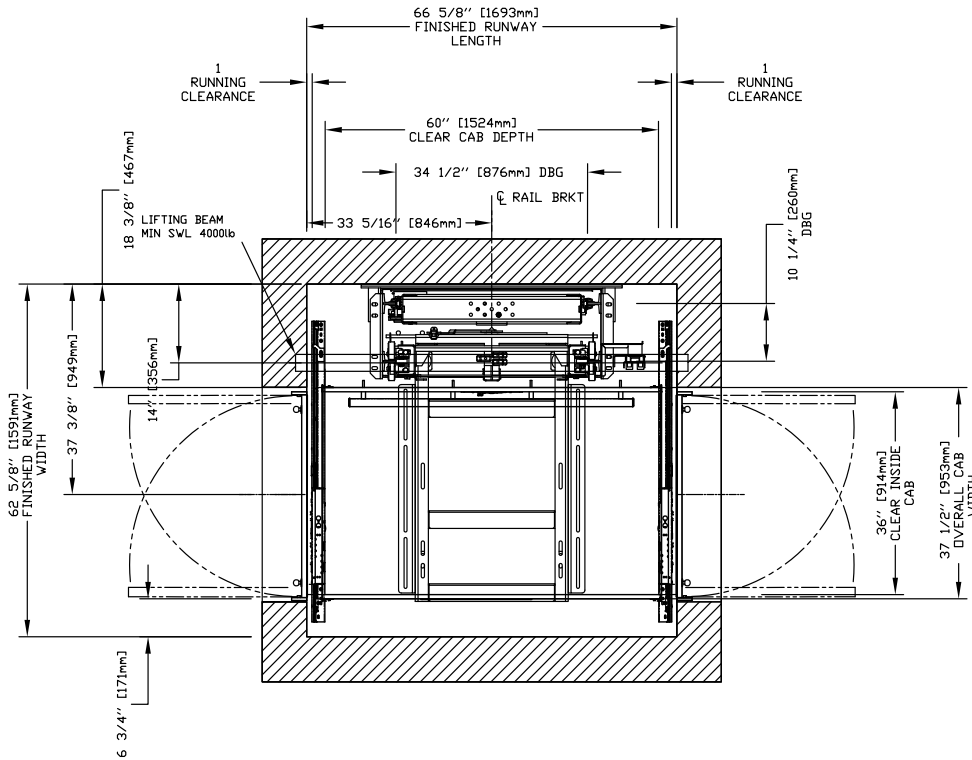

**IMPORTANT**

Finished hoistway dimensions must include the drywall. Determine the fire rating of the hoistway and the type and layers of sheet rock. Build only from the final shop drawings specific to your installation.

### 36" x 60" Type 2 Cab, Auto Slim (29.5") Doors

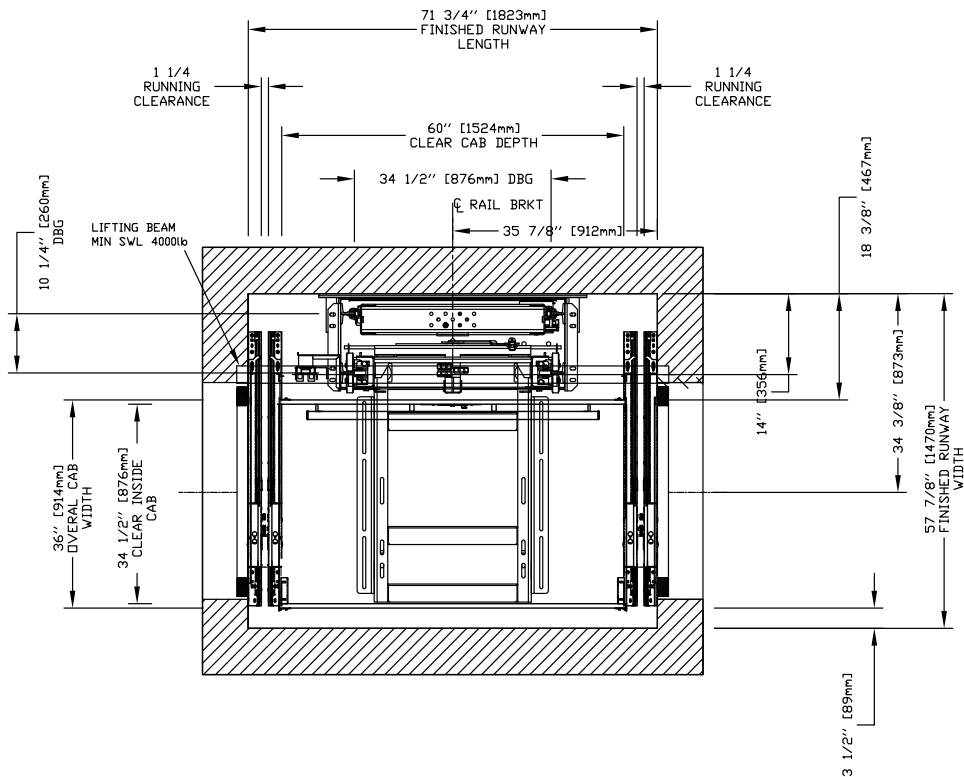

### 36" x 60" Type 2 Cab, Auto Slim (29.5") Doors + Swing

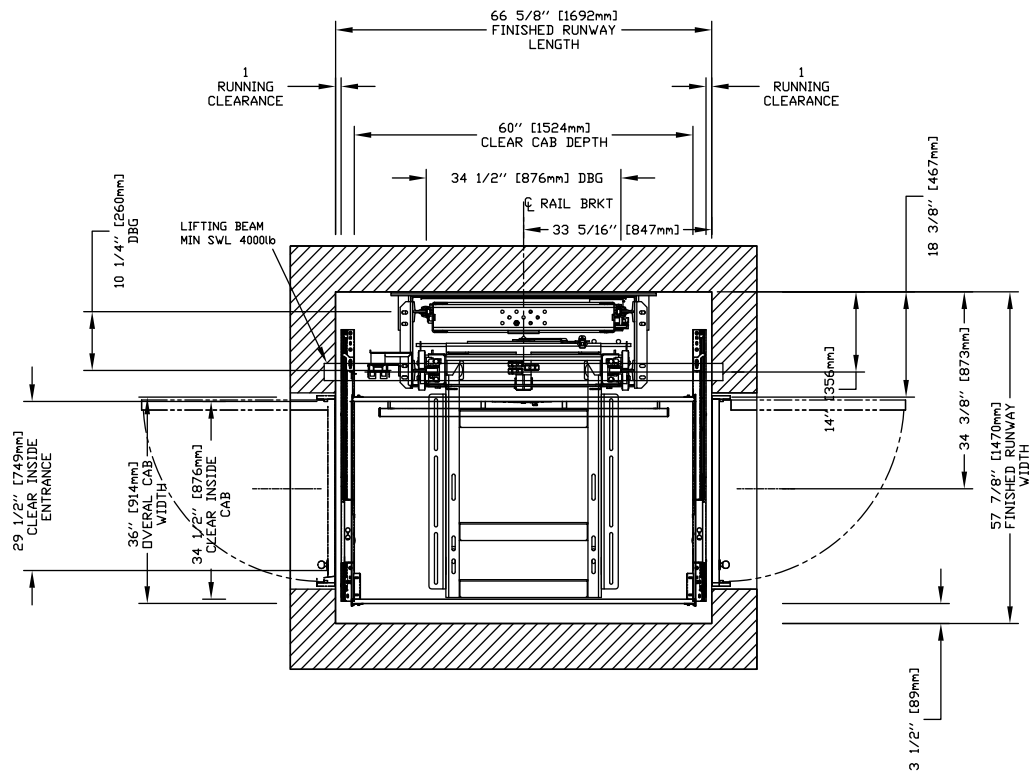

**IMPORTANT**

Finished hoistway dimensions must include the drywall. Determine the fire rating of the hoistway and the type and layers of sheet rock. Build only from the final shop drawings specific to your installation.

### 36" x 60" Type 3 Cab, Auto Slim (35.5") Doors

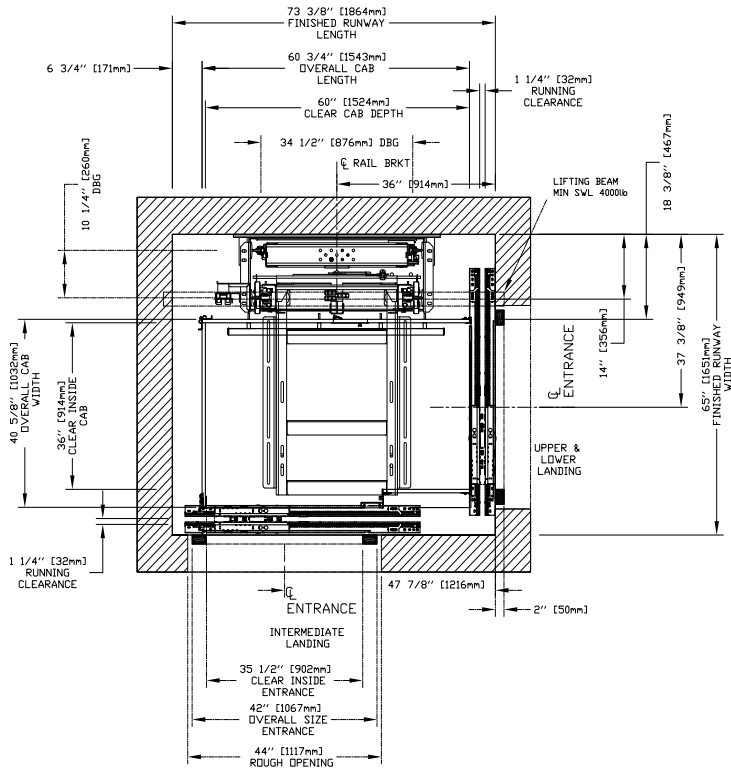

### 36" x 60" Type 3 Cab, Auto Slim (35.5") Doors + Swing

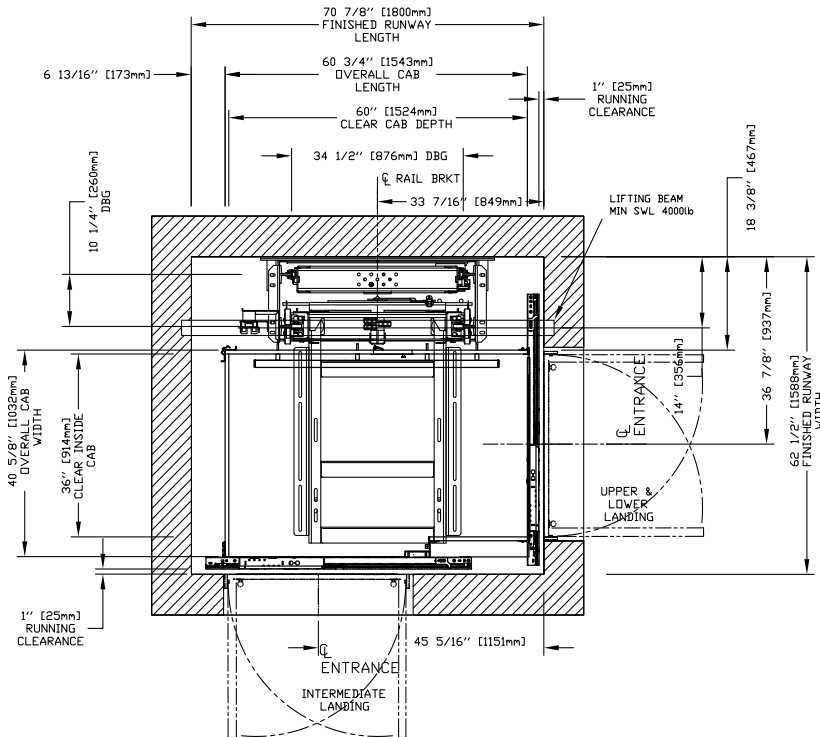

**IMPORTANT**

Finished hoistway dimensions must include the drywall. Determine the fire rating of the hoistway and the type and layers of sheet rock. Build only from the final shop drawings specific to your installation.



### 36" x 60" Type 3 Cab, Auto Slim (29.5") Doors

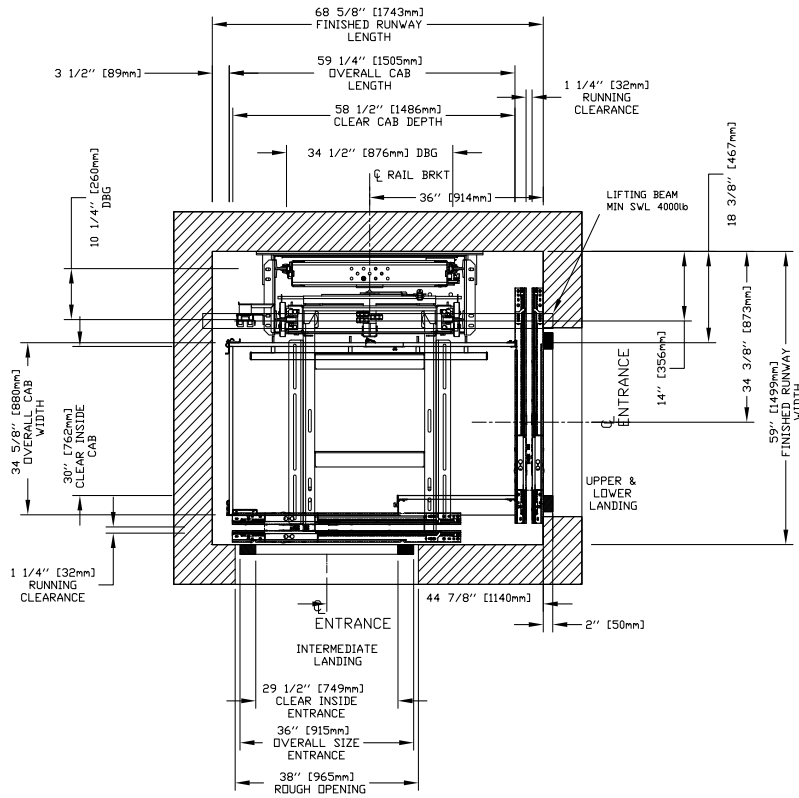

### 36" x 60" Type 3 Cab, Auto Slim (29.5") Doors + Swing

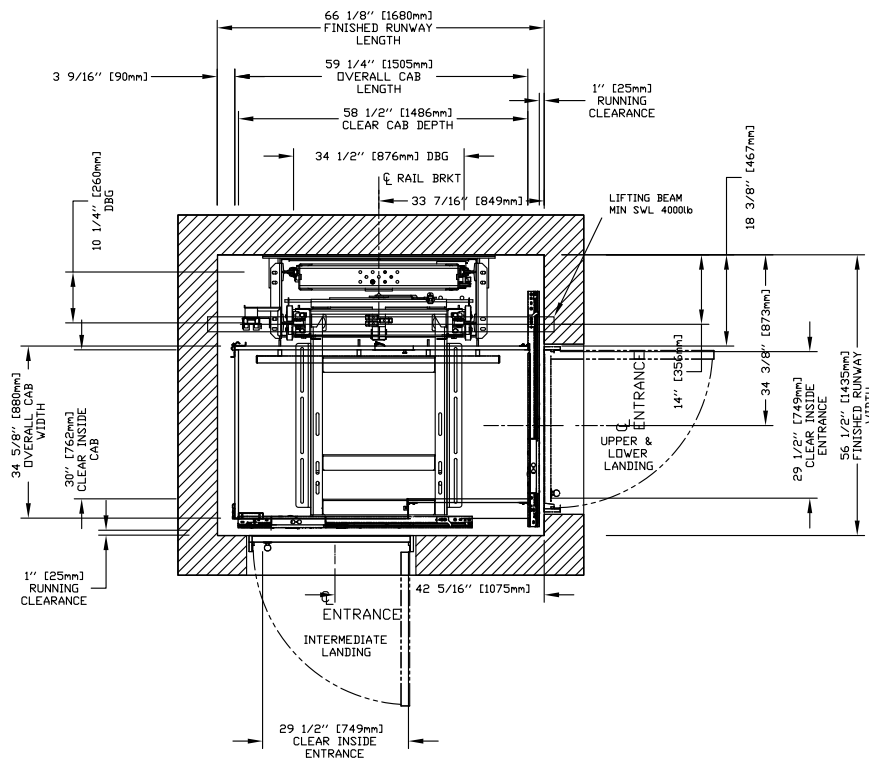

**IMPORTANT**

Finished hoistway dimensions must include the drywall. Determine the fire rating of the hoistway and the type and layers of sheet rock. Build only from the final shop drawings specific to your installation.

### 36" x 60" Type 4 Cab, Auto Slim (35.5") Doors

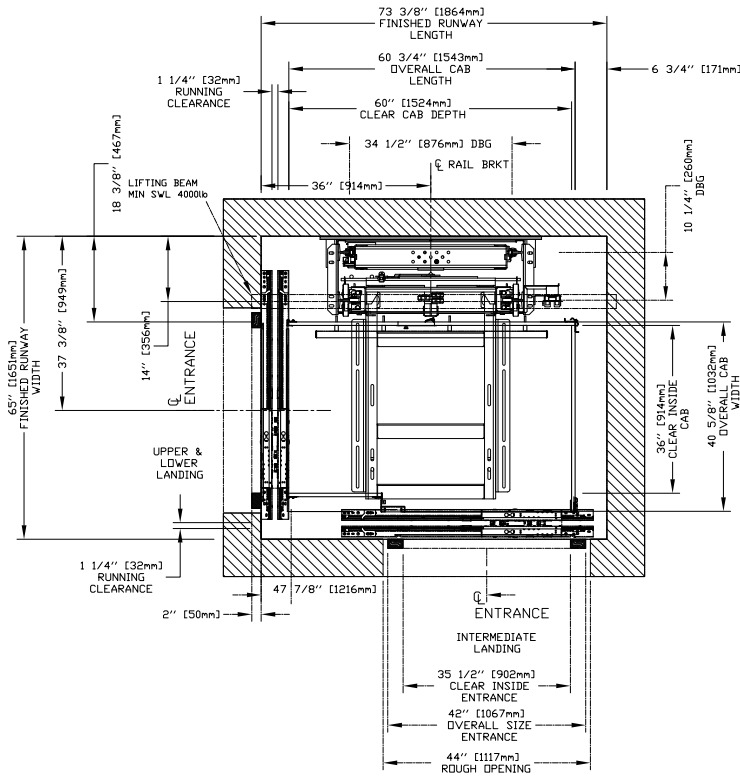

### 36" x 60" Type 4 Cab, Auto Slim (35.5") Doors + Swing

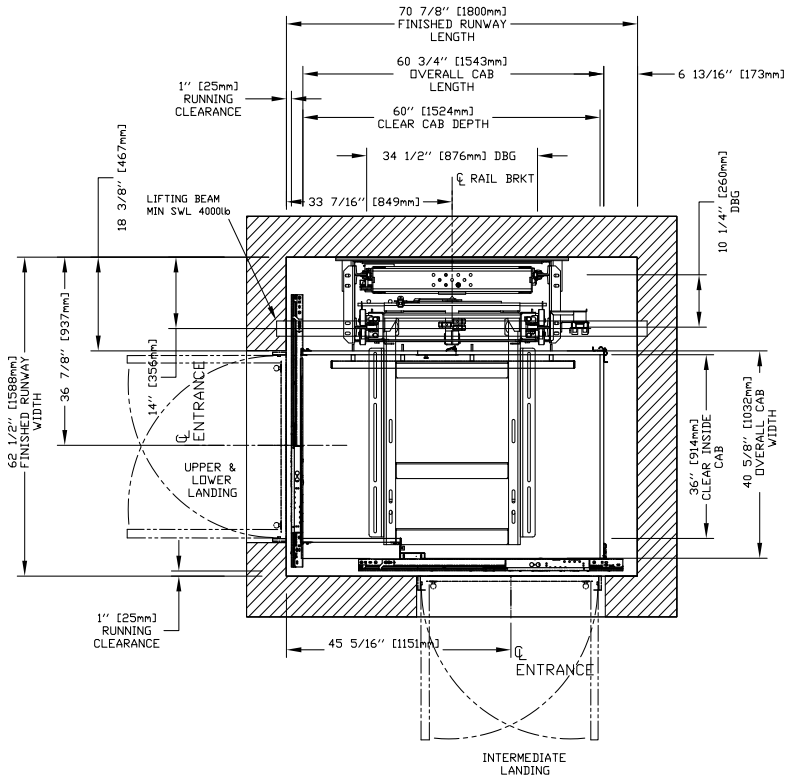

**IMPORTANT**

Finished hoistway dimensions must include the drywall. Determine the fire rating of the hoistway and the type and layers of sheet rock. Build only from the final shop drawings specific to your installation.

### 36" x 60" Type 4 Cab, Auto Slim (29.5") Doors

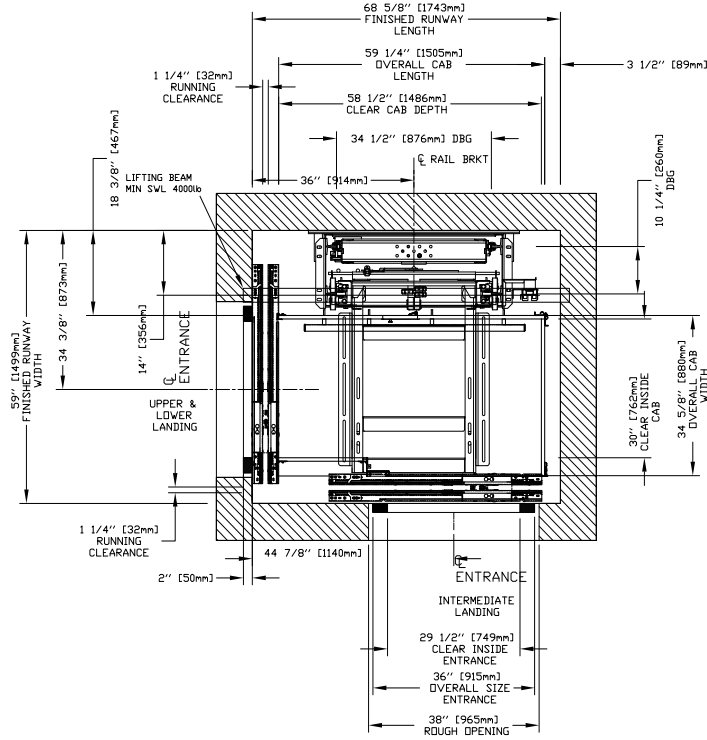

### 36" x 60" Type 4 Cab, Auto Slim (29.5") Doors + Swing

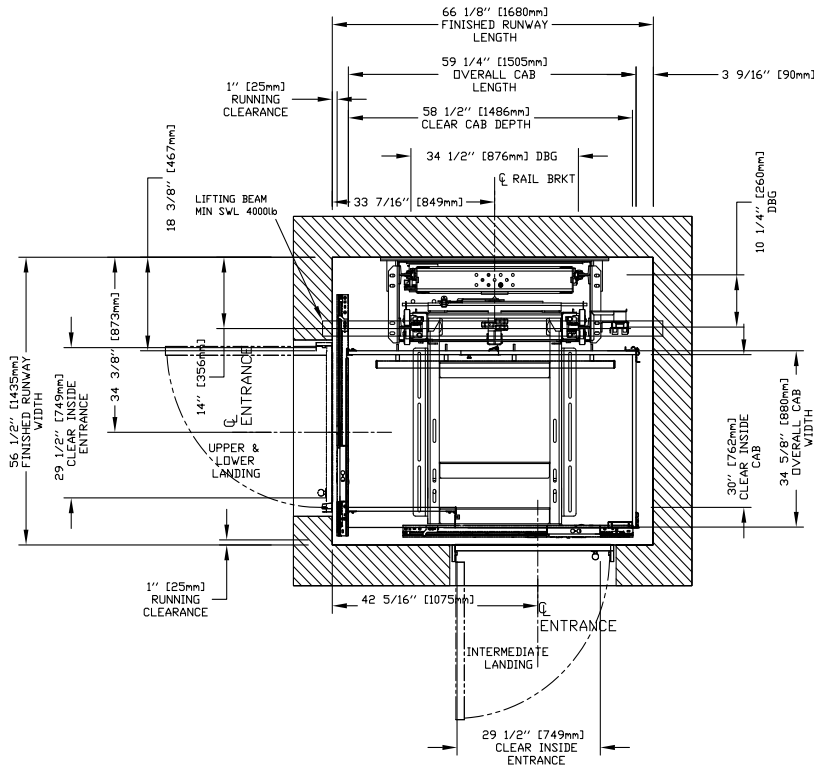

**IMPORTANT**

Finished hoistway dimensions must include the drywall. Determine the fire rating of the hoistway and the type and layers of sheet rock. Build only from the final shop drawings specific to your installation.

### 36" x 60" Type 5 Cab, Auto Slim (35.5") Doors

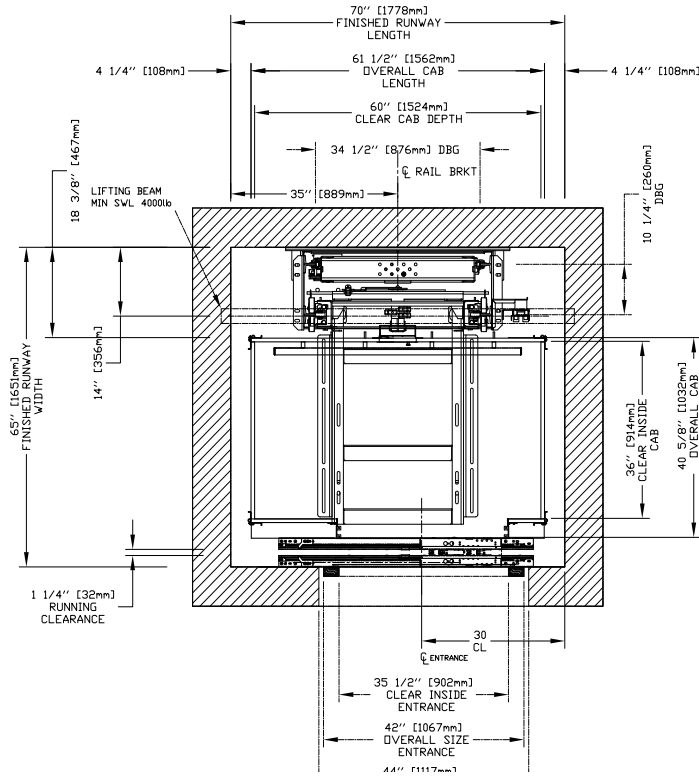

### 36" x 60" Type 5 Cab, Auto Slim (35.5") Doors + Swing

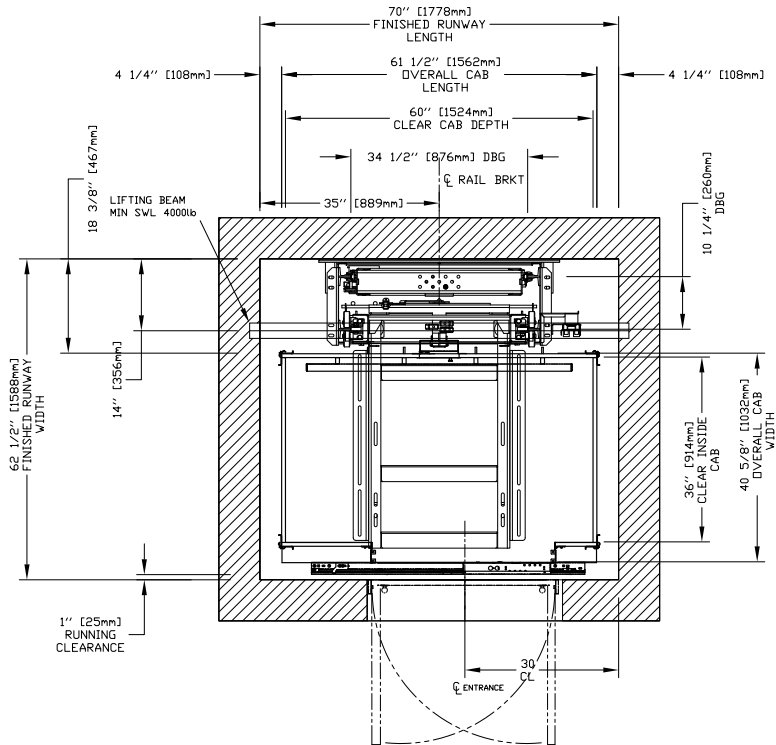

**IMPORTANT**

Finished hoistway dimensions must include the drywall. Determine the fire rating of the hoistway and the type and layers of sheet rock. Build only from the final shop drawings specific to your installation.

### 36" x 60" Type 5 Cab, Auto Slim (29.5") Doors

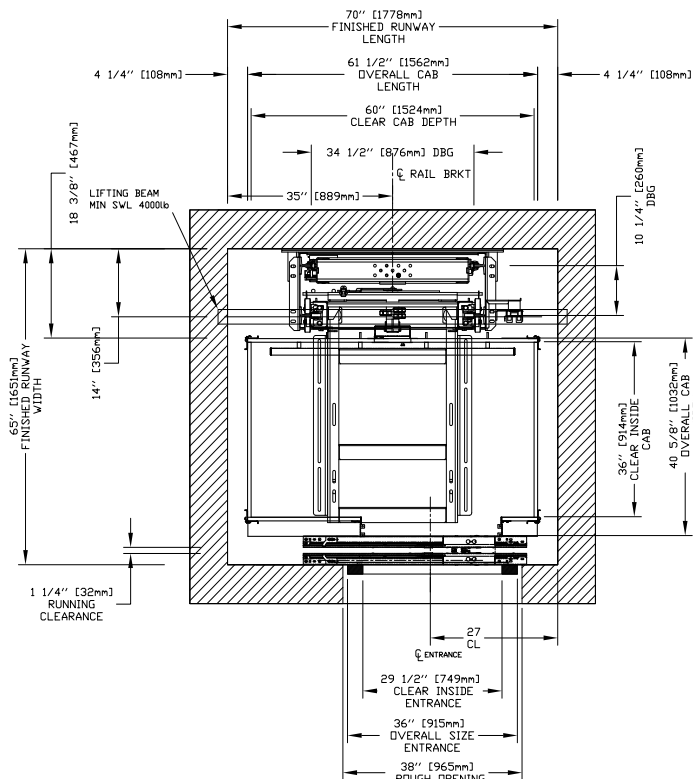

### 36" x 60" Type 5 Cab, Auto Slim (29.5") Doors + Swing

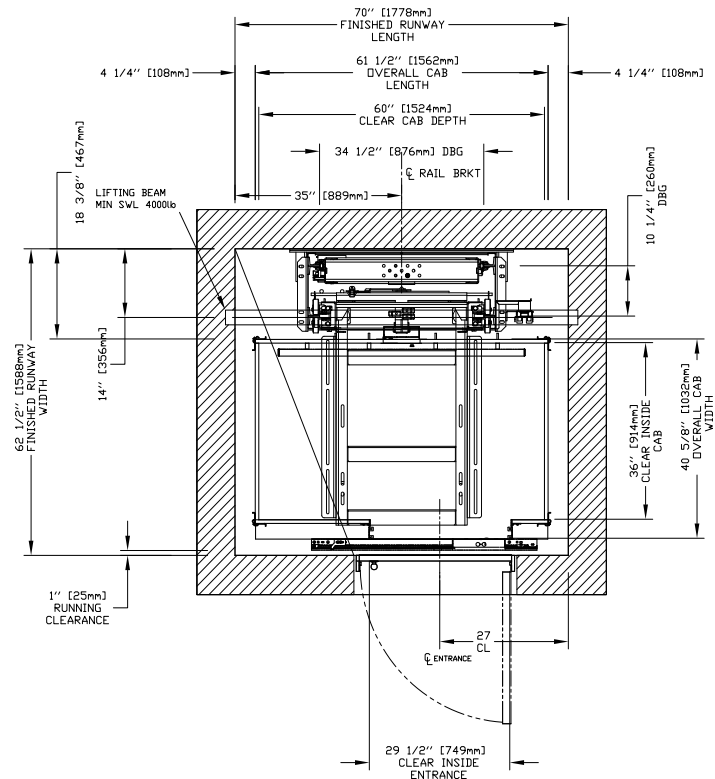

**IMPORTANT**

Finished hoistway dimensions must include the drywall. Determine the fire rating of the hoistway and the type and layers of sheet rock. Build only from the final shop drawings specific to your installation.

### 40" x 48" Type 1L Cab, Auto Slim (35.5") Doors

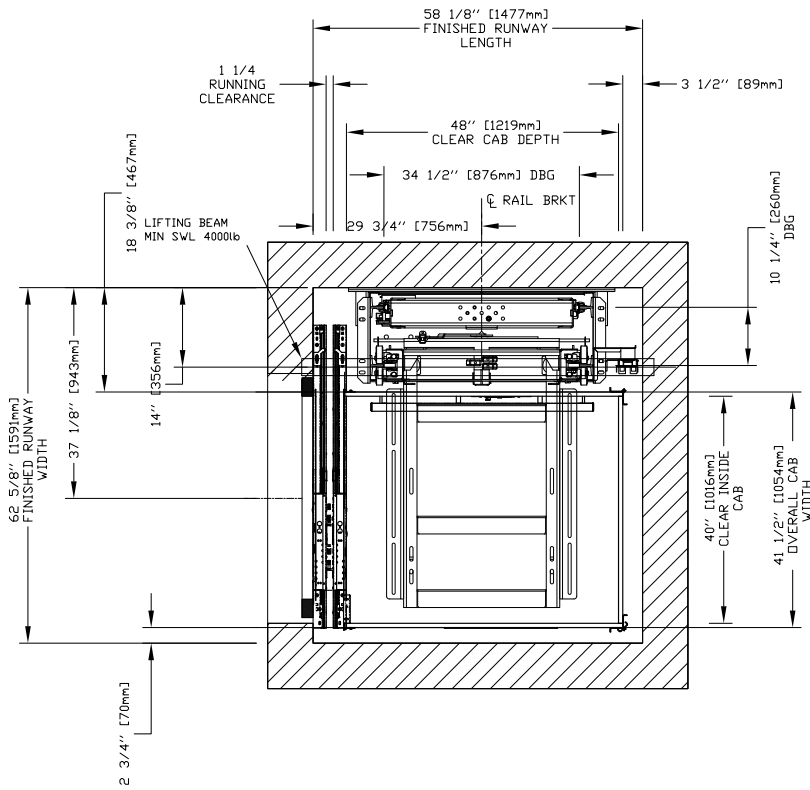

### 40" x 48" Type 1R Cab, Auto Slim (35.5") Doors

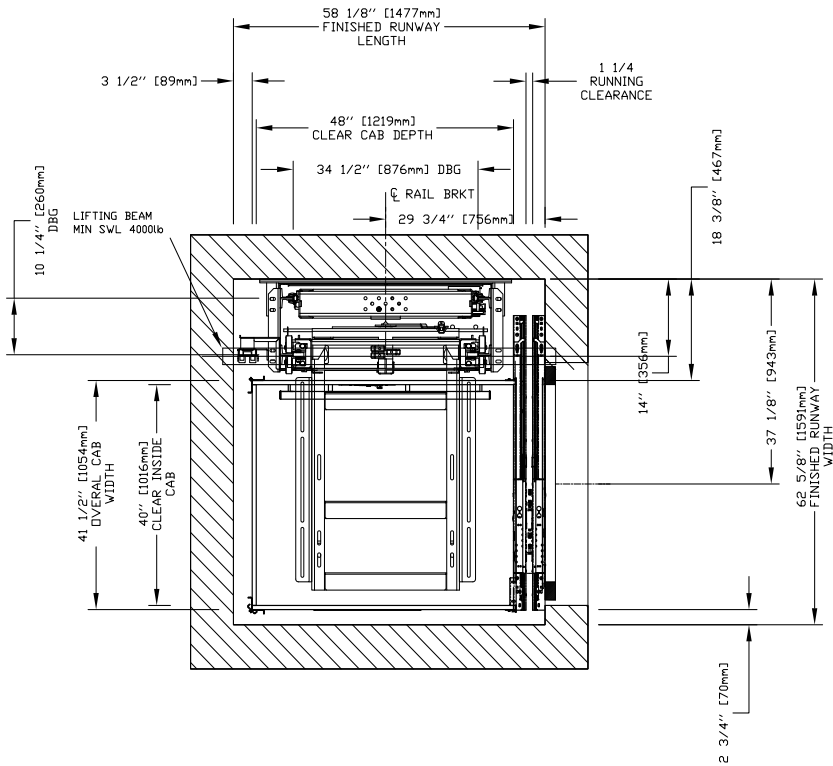

**IMPORTANT**

Finished hoistway dimensions must include the drywall. Determine the fire rating of the hoistway and the type and layers of sheet rock. Build only from the final shop drawings specific to your installation.

### 40" x 48" Type 2 Cab, Auto Slim (35.5") Doors

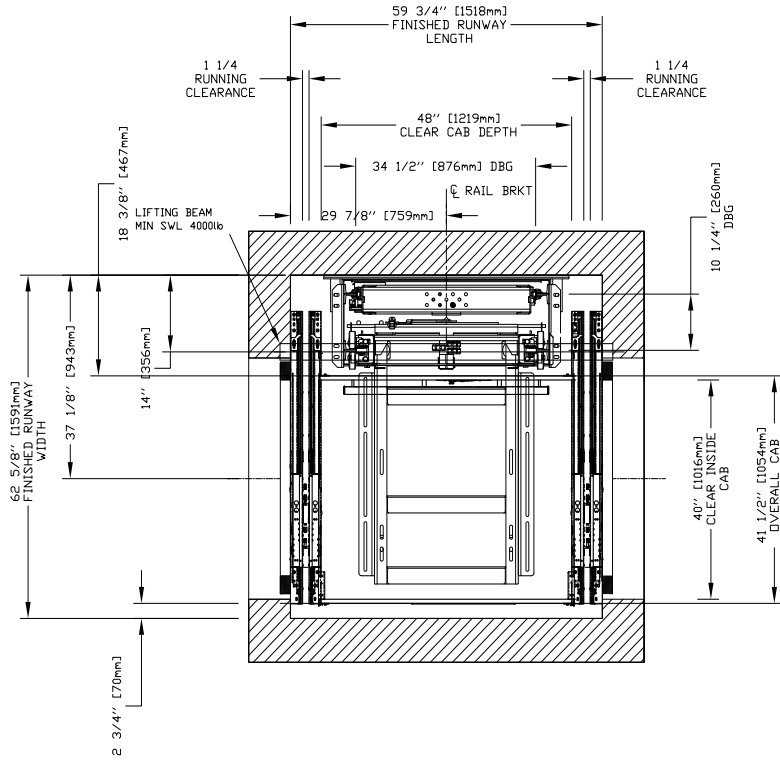

### 40" x 54" Type 1L Cab, Auto Slim (35.5") Doors

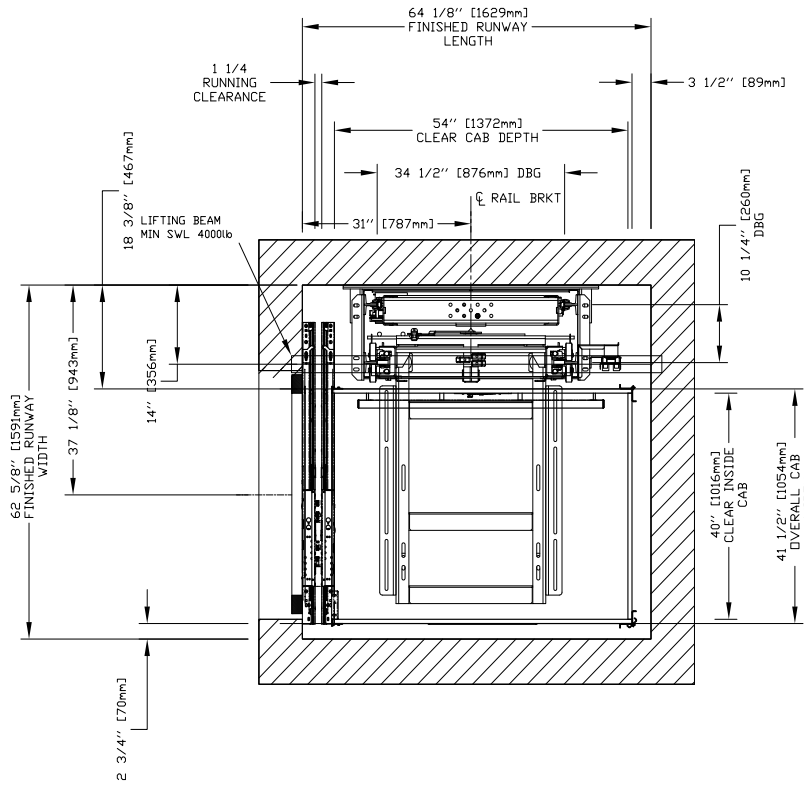

**IMPORTANT**

Finished hoistway dimensions must include the drywall. Determine the fire rating of the hoistway and the type and layers of sheet rock. Build only from the final shop drawings specific to your installation.

### 40" x 54" Type 1L Cab, Auto Slim (35.5") Doors + Swing

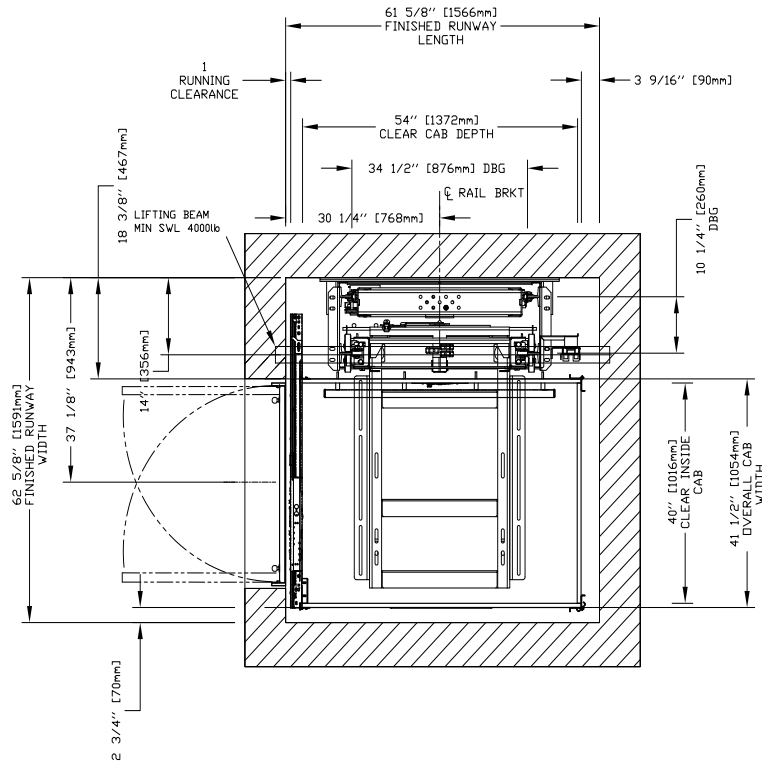

### 40" x 54" Type 1R Cab, Auto Slim (35.5") Doors

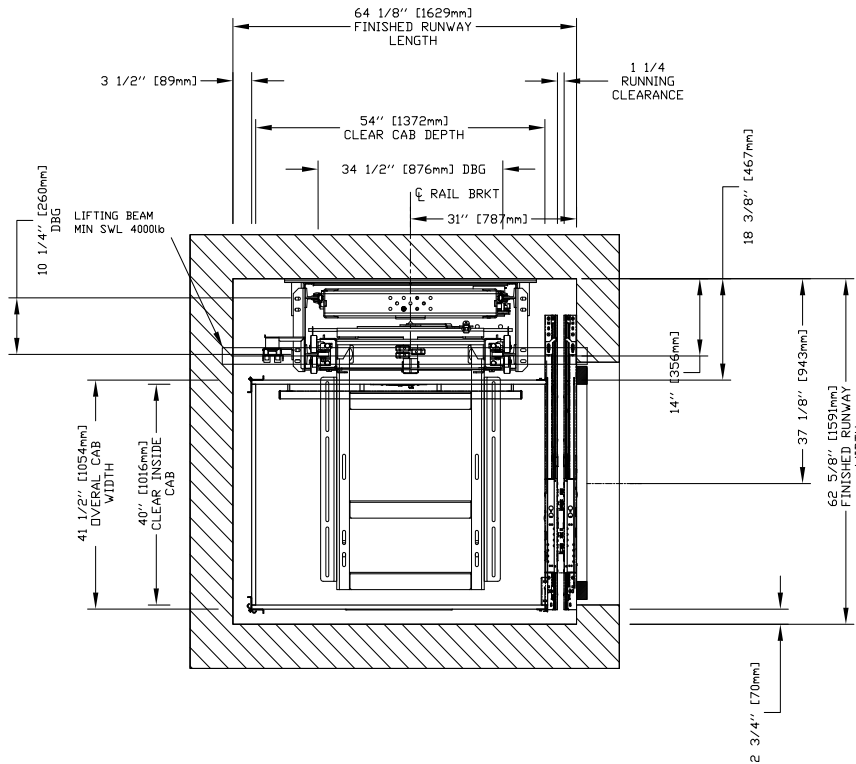

**IMPORTANT**

Finished hoistway dimensions must include the drywall. Determine the fire rating of the hoistway and the type and layers of sheet rock. Build only from the final shop drawings specific to your installation.



### 40" x 54" Type 1R Cab, Auto Slim (35.5") Doors + Swing

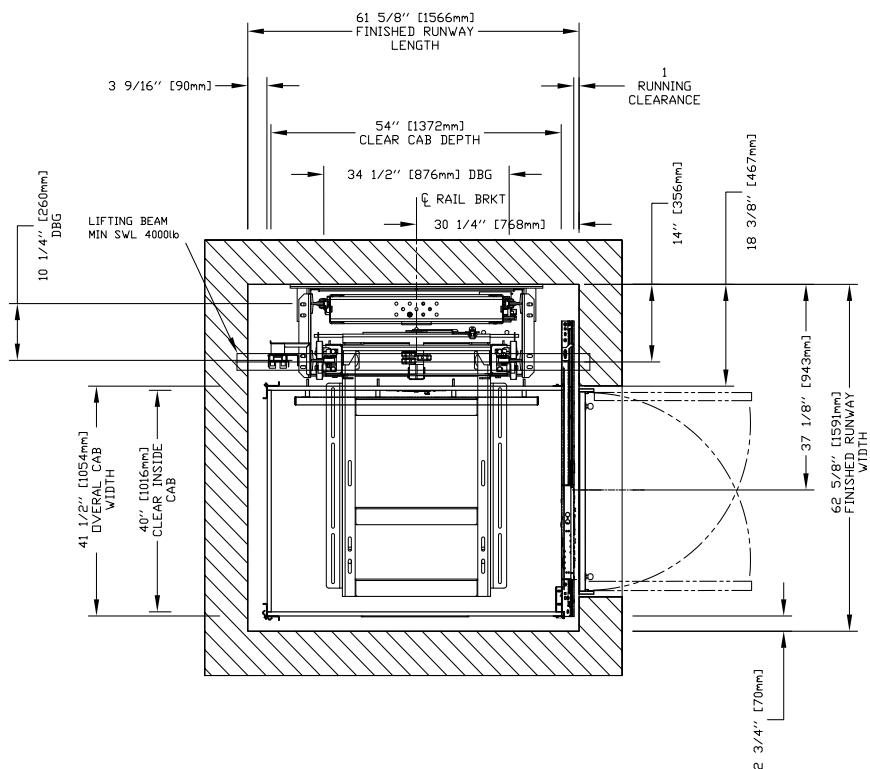

### 40" x 54" Type 2 Cab, Auto Slim (35.5") Doors

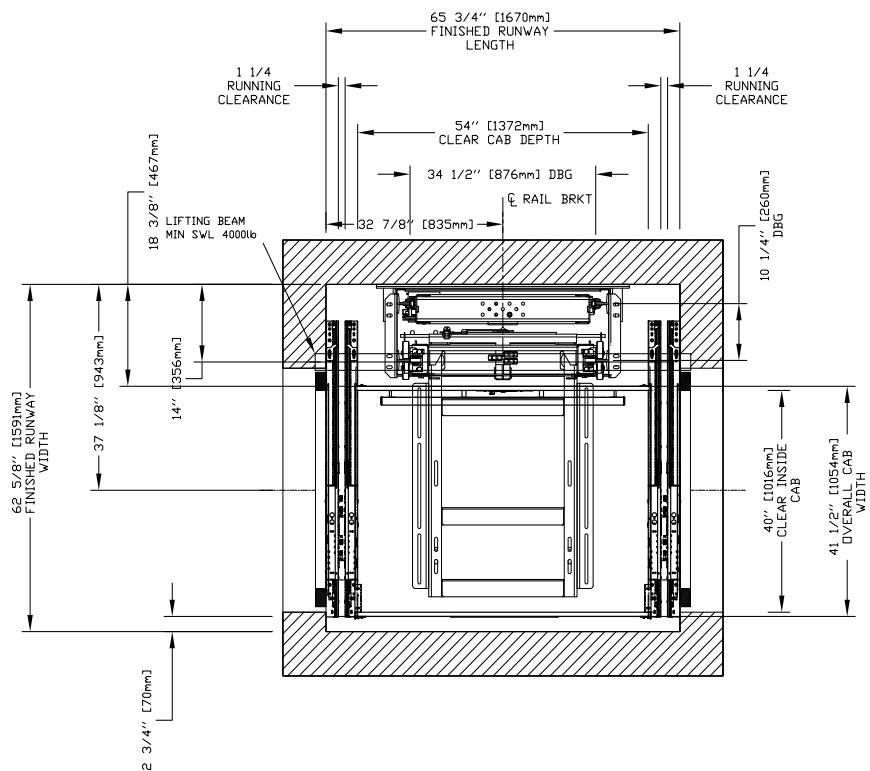

**IMPORTANT**

Finished hoistway dimensions must include the drywall. Determine the fire rating of the hoistway and the type and layers of sheet rock. Build only from the final shop drawings specific to your installation.

### 40" x 54" Type 2 Cab, Auto Slim (35.5") Doors + Swing

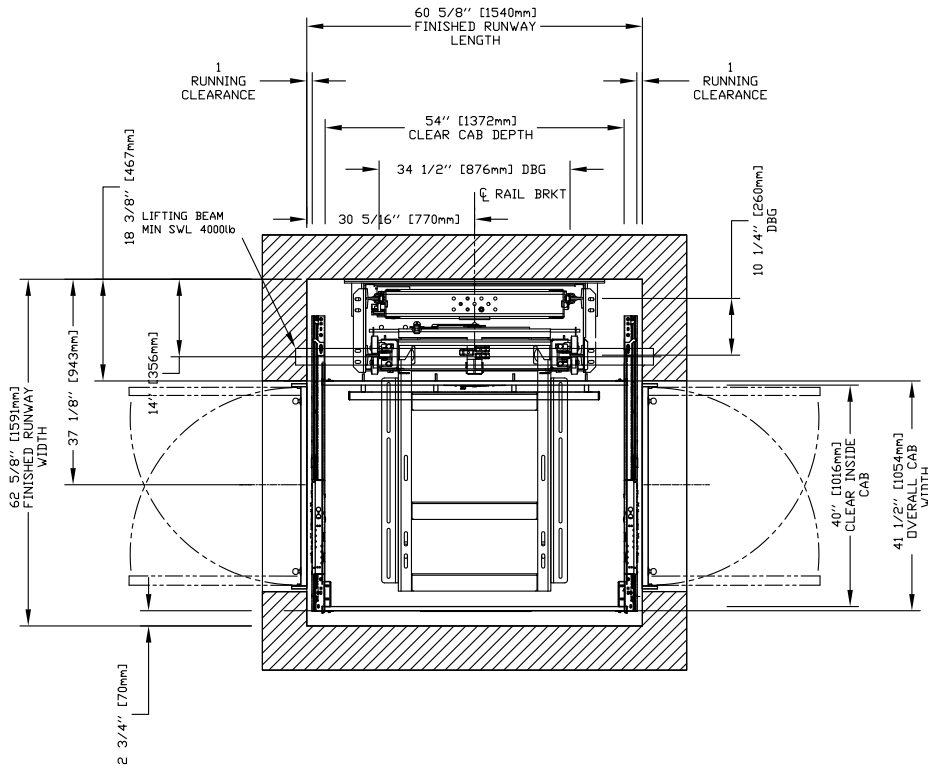

### 40" x 54" Type 3 Cab, Auto Slim (35.5") Doors

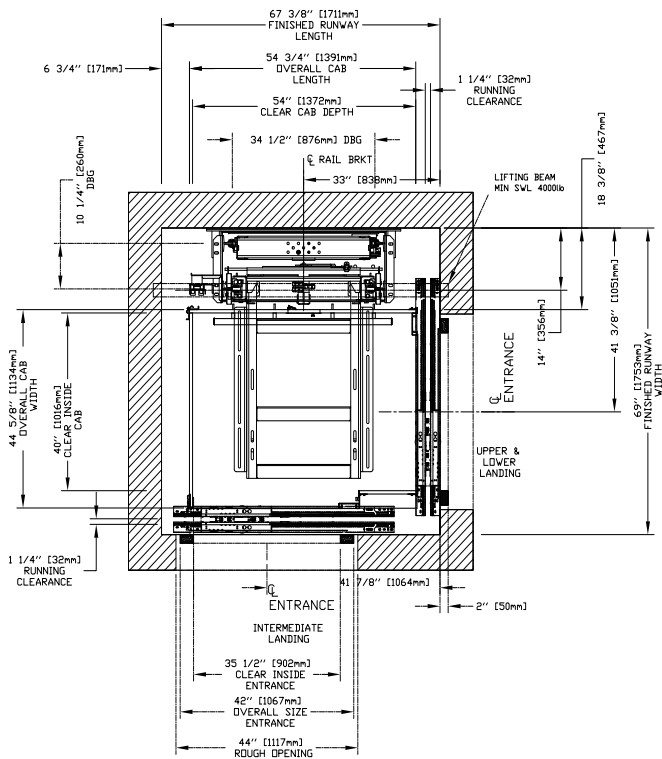

**IMPORTANT**

Finished hoistway dimensions must include the drywall. Determine the fire rating of the hoistway and the type and layers of sheet rock. Build only from the final shop drawings specific to your installation.

## 40" x 54" Type 3 Cab, Auto Slim (35.5") Doors + Swing

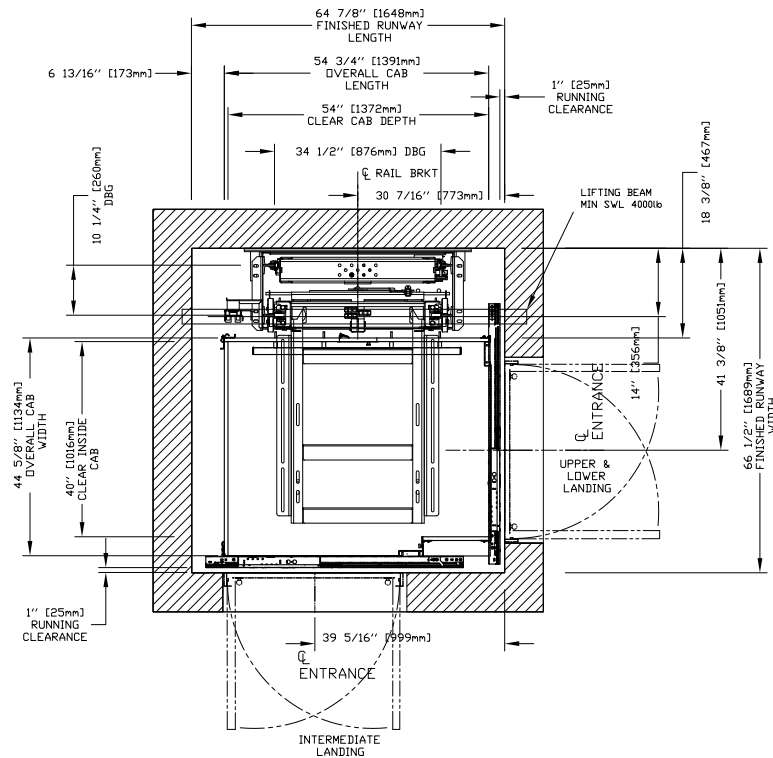

## 40" x 54" Type 4 Cab, Auto Slim (35.5") Doors

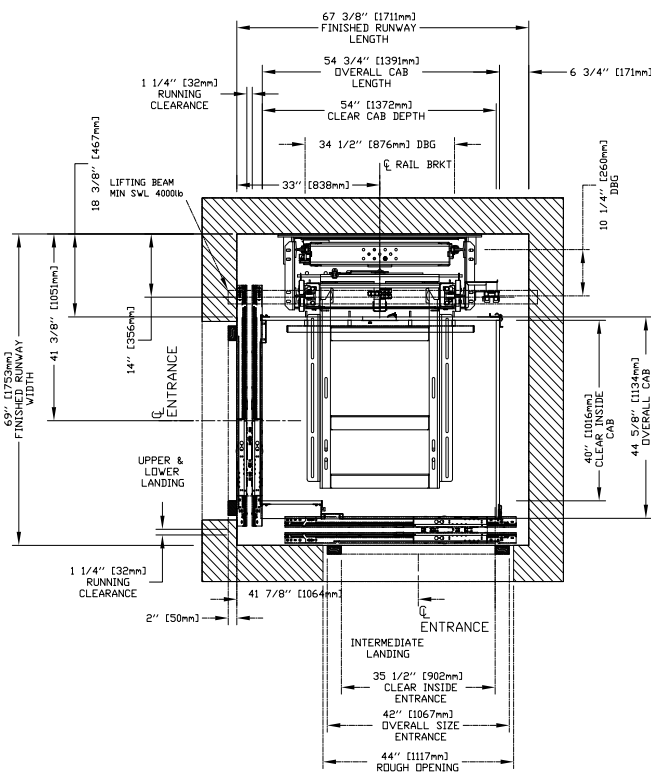

### IMPORTANT

Finished hoistway dimensions must include the drywall. Determine the fire rating of the hoistway and the type and layers of sheet rock. Build only from the final shop drawings specific to your installation.

## 40" x 54" Type 4 Cab, Auto Slim (35.5") Doors + Swing

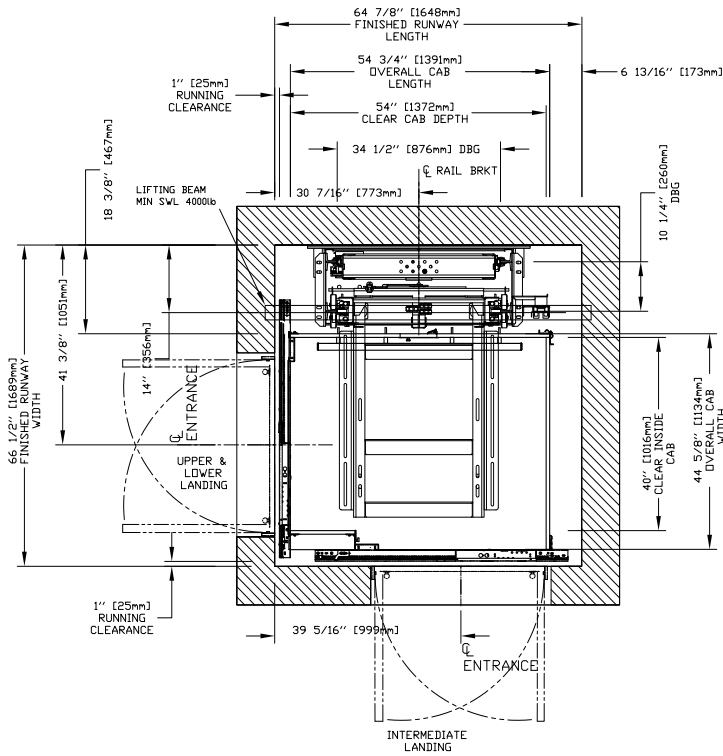

## 40" x 54" Type 5 Cab, Auto Slim (35.5") Doors

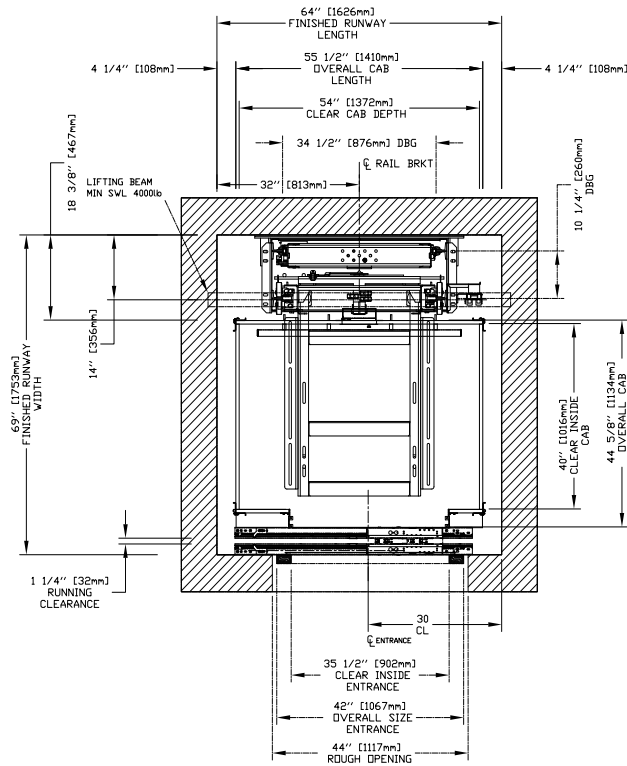

### IMPORTANT

Finished hoistway dimensions must include the drywall. Determine the fire rating of the hoistway and the type and layers of sheet rock. Build only from the final shop drawings specific to your installation.

## 40" x 54" Type 5 Cab, Auto Slim (35.5") Doors + Swing

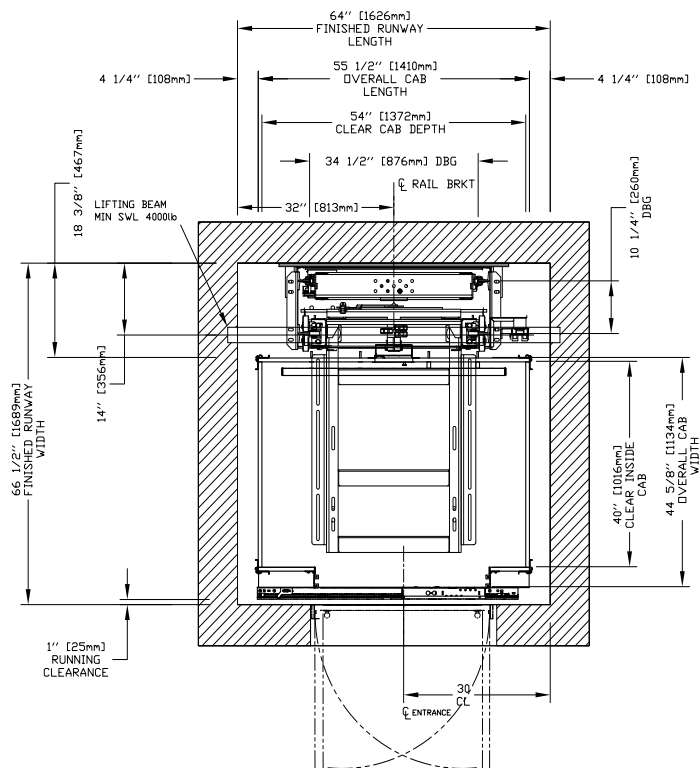

### IMPORTANT

Finished hoistway dimensions must include the drywall. Determine the fire rating of the hoistway and the type and layers of sheet rock. Build only from the final shop drawings specific to your installation.

# Auto slim doors entrance assembly, CO = 2100

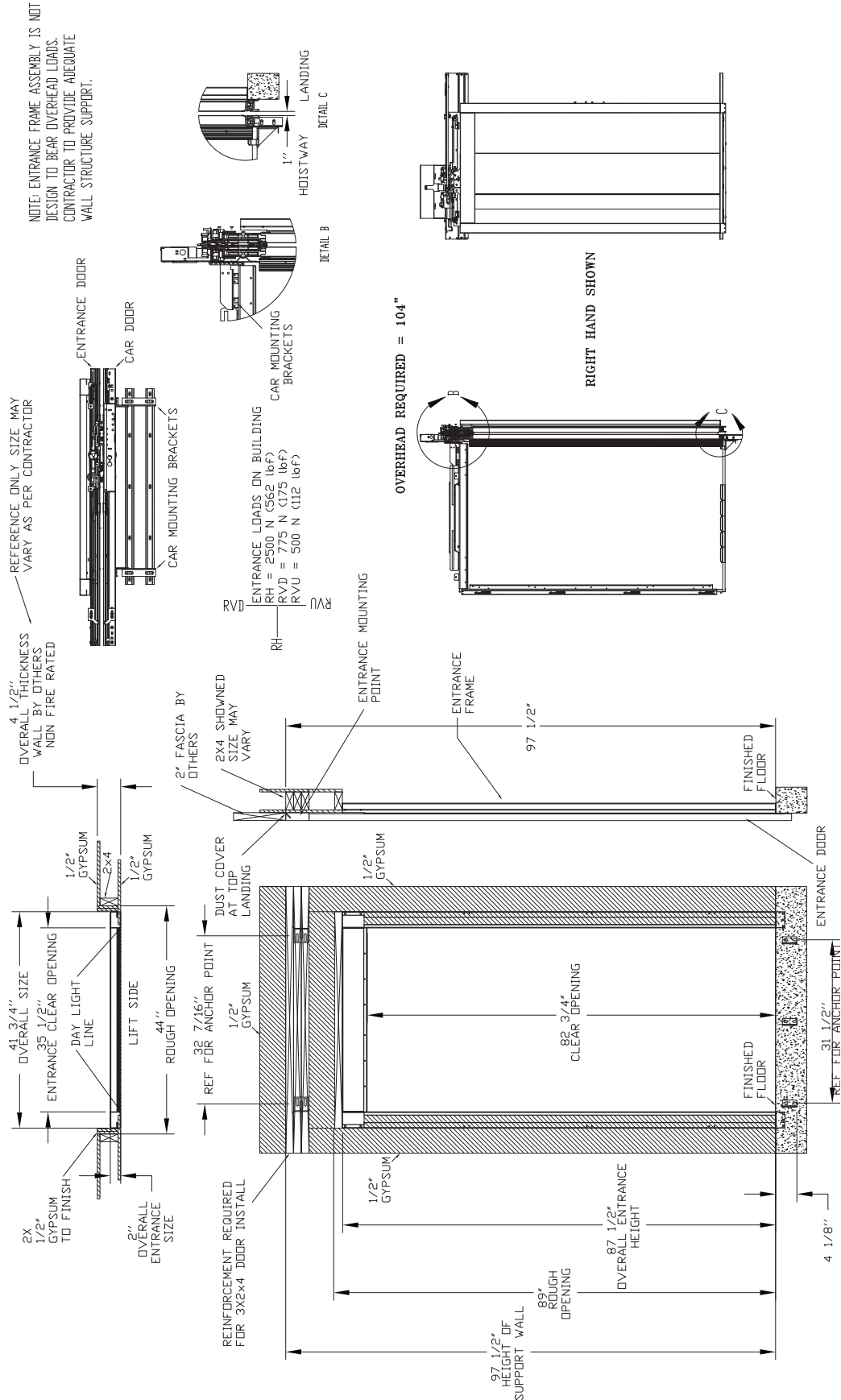

## Hoistway and Pit Notes

- A load bearing wall is required to sustain rail reactions. Refer to section on rail forces.
- Suggested hoistway pit floor construction consists of an 8" (203 mm) concrete slab poured on a natural or compacted soil with a minimum allowable bearing pressure of 1.0 KSF.
- The minimum compressive strength of the concrete at 28 days must be no less than 3000 PSI. #5 reinforcing steel (grade 60) must be placed at the bottom of the slab in 2 traverse directions and at a spacing of 12" (305 mm).
- Hoistway pit floor to support a load of 10 kips (10,000 lbs)/44.48KN (includes impact).
- 108" (2743 mm) minimum overhead clearance required above the top landing floor
- 10" (254 mm) minimum pit. (A clearance device is provided to attain required 36" (914 mm) refuge space).
- Hoistway sizes reflect running and access clearances only. Consult your local AHJ to assure compliance with local codes.
- Hoistway is required to be free of all pipes, wiring and obstructions not related to the operation of the elevator.
- If a dedicated pit light is required by your local AHJ, please follow the guidelines below for accommodating this in your hoistway.

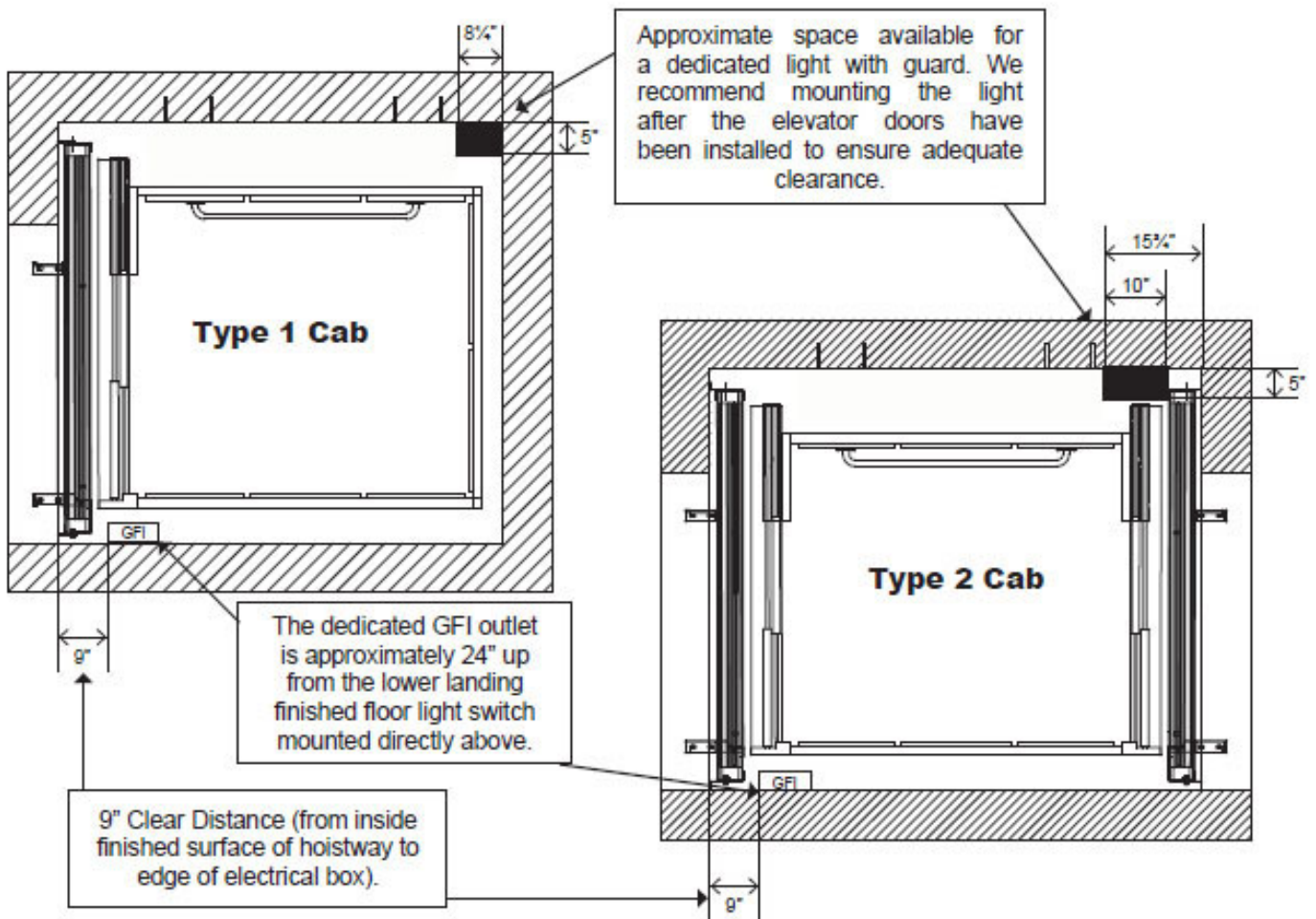

# Loads on Building and Pit Loading

Rail reactions do not include safety factors. Applicable safety factors must be considered in hoistway design.

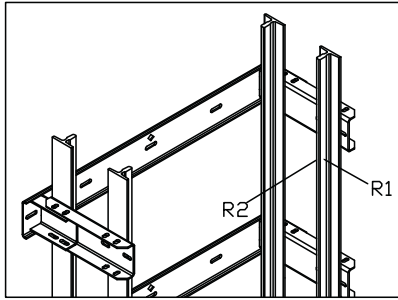

RAIL FORCES	
*R1	*R2
932 lbf	260 lbf
RAIL WEIGHT : 8.0 lbs / ft	

FOR TOTAL PULL-OUT FORCE ON RAIL BRACKET,  
 eg.  $2 \times 932 = 1864$  lbf  
 FOR LOCAL APPLICATION OF PIT LOAD,  
 R1 MUST BE DOUBLED.

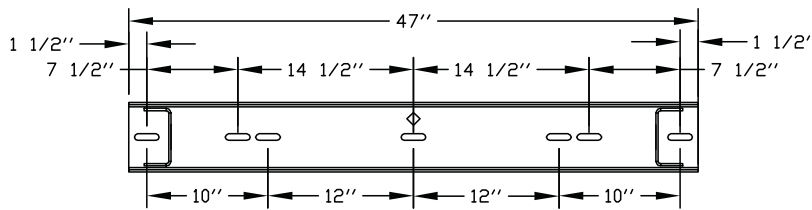

RAIL BRACKETS

R1 LOAD ON EACH FIXING POINT EQUALS  
 466 LBF BASED ON FOUR MOUNTING HOLES

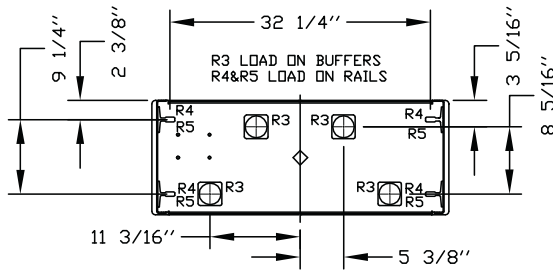

RAIL BRACKETS

PIT PLATE LAYOUT

PIT RE-ACTION FORCE		
R3	8000 LBS	PER LOAD POINT 2000 LBS
R4	3000 LBS	PER LOAD POINT 750 LBS
R5	9500 LBS	PER LOAD POINT 2375 LBS



# Rail Support Wall Structure

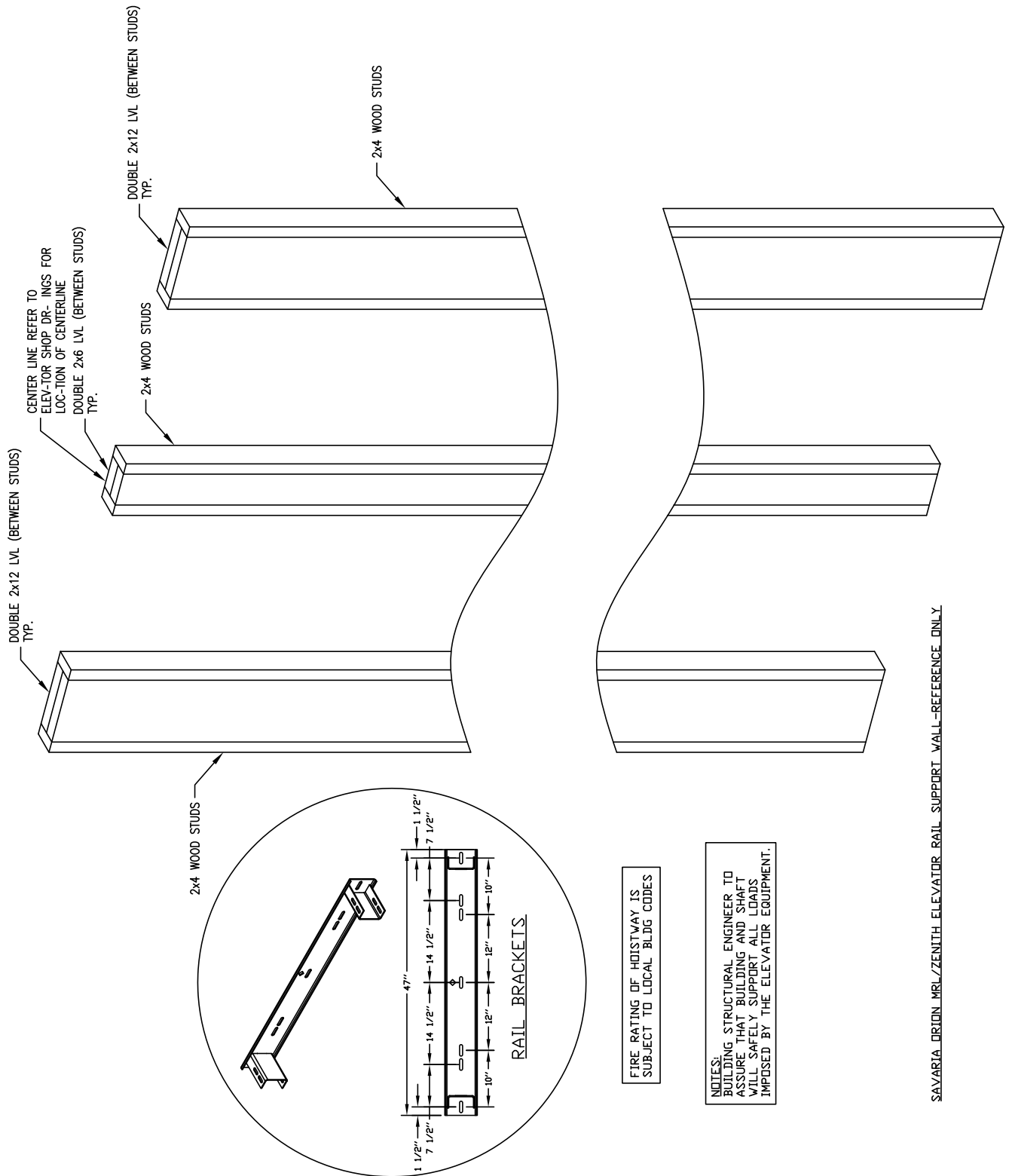

SAVARIA DRON MRL/ZENITH ELEVATOR RAIL SUPPORT WALL-REFERENCE ONLY

## Controller Box Dimensions

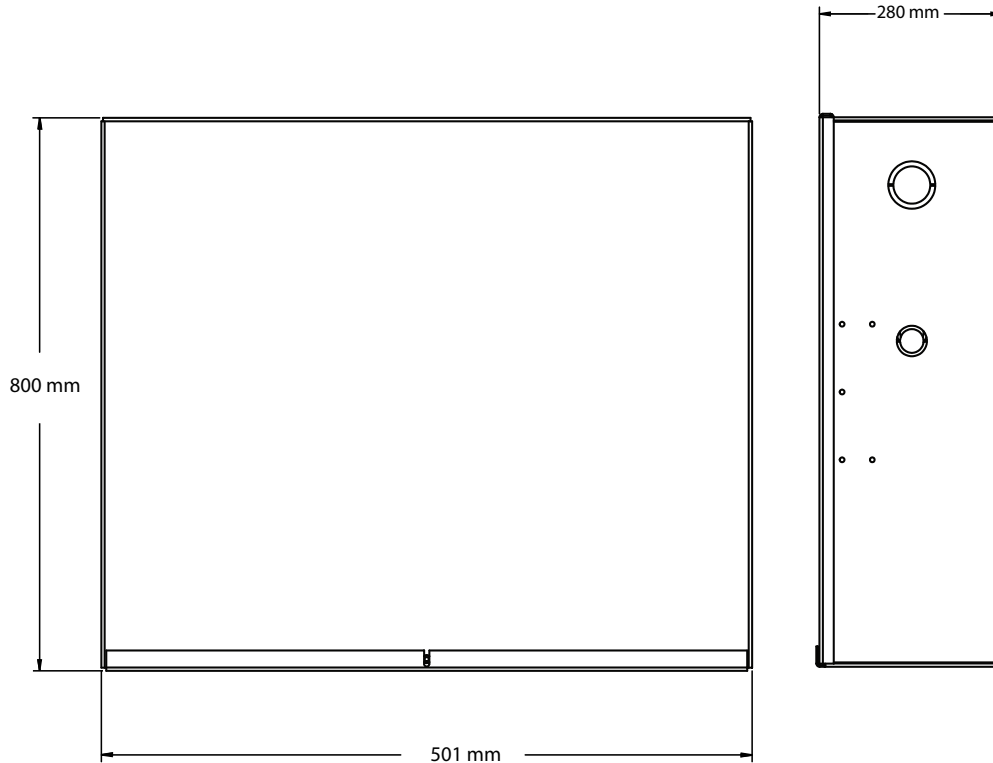

Remote Controller, 5.0 HP (3.5 KW)

**NOTE:** A remote controller cannot be more than 100 ft (30.5 m) from the top of the unit for the cable to reach

## Provisions By Others

### Hoistway

- The hoistway must be in accordance with the "Safety Code for Elevators and Escalators" (ASME A17.1) and all state and local codes.

### Plumb Hoistway

- Due to close running clearances, the owner/agent must ensure that the hoistway and pit (where provided) are level, plumb and square and are in accordance with the dimensions on the installation (shop) drawings.

### Minimum Overhead Clearance

- Owner/agent must ensure the minimum overhead clearance is in compliance with codes.

### Construction Site

- Owner/agent to provide all masonry, carpentry and drywall work as required and shall patch and make good (including finish painting) all areas where walls/floors may need to be cut, drilled or altered in any way to permit the proper installation of the lift.

### Dimensions

- Contractor/customer to verify all dimensions and report any discrepancies to our office immediately.

## Structural

### Floor Support/Wall Loads

- Structure to anchor a crank shaft and safety harness, where applicable/needed, to be provided by contractor. Contractor to assure that the building and shaft will safely support all loads imposed by the lift equipment. Refer to the tables on the installation (shop) drawings for loads imposed by the equipment.

## Machine Room (Where Required)

### Location/Access

- Machine room located at the lowest level adjacent to the hoistway, unless shown otherwise on the layout drawings. Field adjustment by installer may be necessary to meet job site conditions or regulations. Machine room door is to be lockable and is to meet the requirements of the authority having jurisdiction.

### Sleeves for Electric Lines

- From machine room to hoistway as required. (Position per installer's instructions.)

## Electrical Power Supply

- See specifications below. Lockable fused disconnect with auxiliary contact to brake the battery feed, or circuit breakers with a 3-pole breaker for battery feed required in compliance with electrical code as follows. (Located on wall on lock jamb side of machine room door.)

	DISCONNECT SIZE	TIME DELAY FUSE SIZE	VOLTS	PHASE	FLA
MOTOR & EQUIPMENT	60 Amps	40 Amps	240 Volts	Single Phase	35.0 Amps
CAB LIGHTS	15 Amps	15 Amps	115 V	Single Phase	

### Permanent Power

- Before installation can begin, permanent power must be supplied.

### Lighting

- The illumination shall not be less than 200 LX (19 FC) at the floor level in all machine rooms and machinery spaces. Ensure at least 100 LX (10 FC) ambient lighting over the lift area.

### Phone

- Need a phone land line.

### Manual Lowering Winch

- Manual lowering winch to be wired into machine space light and outlet.
- Outlet and light in machine space to be on a separate circuit from cab light and elevator motor and have 10 Amps available to operate the winch.
- Does not require separate circuit.

## Entrances

### Fascia Panel Below Upper Level Entrance (Where Required)

- Fascia panel must be fastened to a solid wall and be perpendicular to the floor and walls. Hoistway fascia is not self-supporting for long, continuous runs void of entrances. Adequate support for the fascia must be provided.

## Lifting Beam

- A 4000-lb minimum SWL beam must be provided in the overhead. Beam to be positioned as shown in the elevation and plan views. For overhead of 108", position the underside of the beam at 104" and the beam must be temporary.

# Flush wood door instructions for contractors

## METHOD TO BUILD FLUSH DOOR: USING STOPPER ON INSIDE OF DOOR FRAME

**WARNING** : Lock cut-out in top corner representative of a standard 80" door. For taller doors, such as 84" to 96" the top of the cut-out itself needs to stay at 80" from the ground to allow users access to unlock in case of emergency.



HOISTWAY VIEW WITH 1/8" SHEET-METAL STOPPER

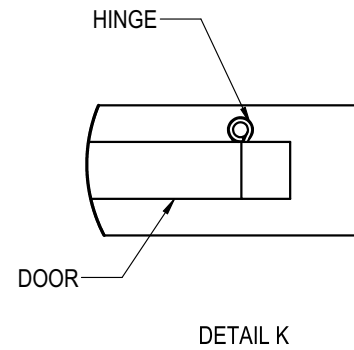
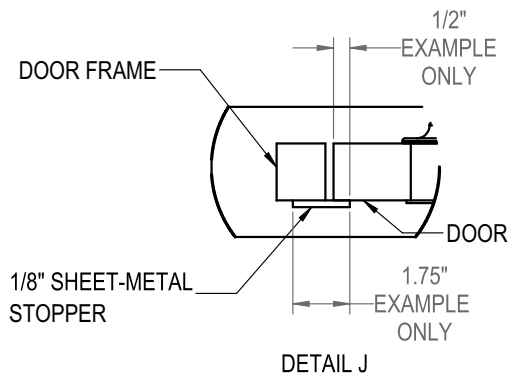
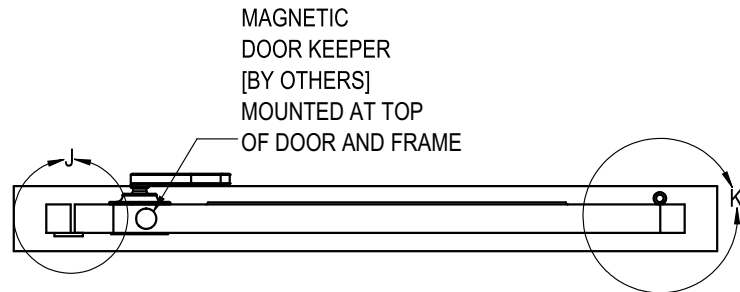

3X HINGES (SPRING HINGES OR DOOR CLOSER ON HYDRAULIC ELEVATOR AND VPL UNITS)

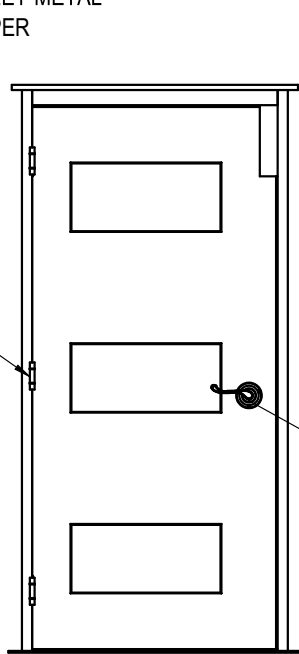

XXX CLEAR DOOR WIDTH  
LANDING VIEW

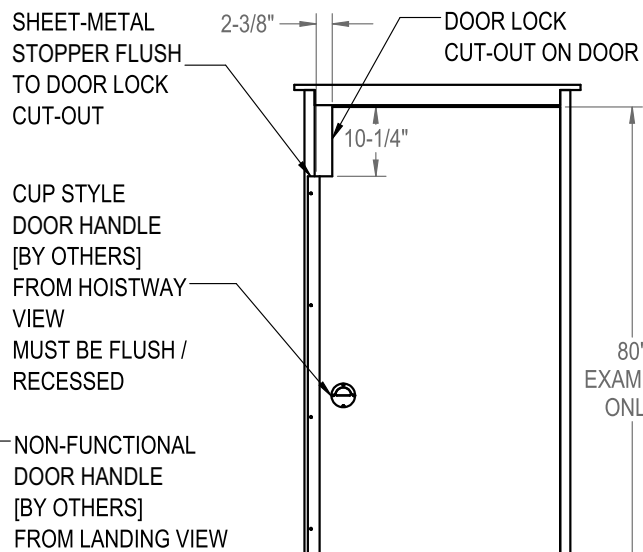

1/8" SHEET-METAL STOPPER  
HOISTWAY VIEW

**Flush wood door instructions for contractors (cont.)**

**METHOD TO BUILD FLUSH DOOR USING ANGLE (L) BRACKET STOPPER**

**WARNING:** Lock cut-out in top corner representative of a standard 80" door. For taller doors, such as 84" to 96", the top of the cut-out itself needs to stay at 80" from the ground to allow users access to unlock in case of emergency.



HOUSE VIEW WITH "L" BRACKET STOPPER

MAGNETIC DOOR KEEPER [BY OTHERS] MOUNTED AT TOP OF DOOR AND FRAME

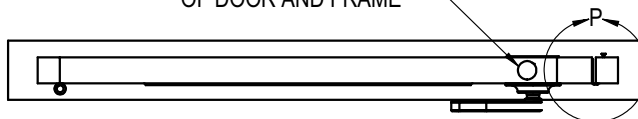

DETAIL M "L" BRACKET MOUNTED ON DOOR SLAB

"L" BRACKET [BY OTHERS]

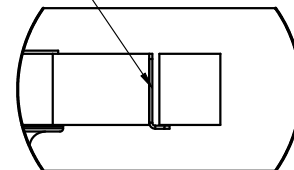

DETAIL P SCALE 1 : 4

CUP STYLE DOOR HANDLE [BY OTHERS] FROM HOISTWAY VIEW MUST BE FLUSH / RECESSED

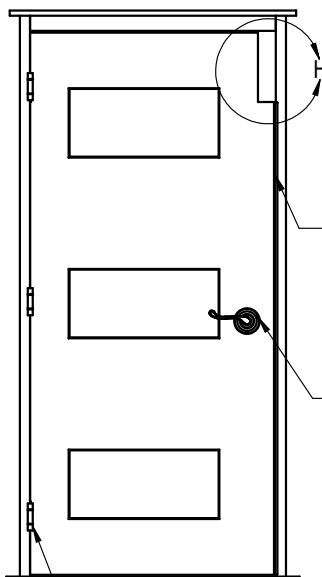
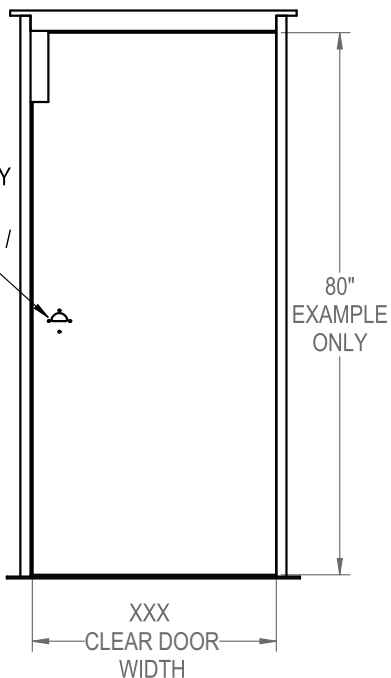

"L" BRACKET [BY OTHERS]  
NON-FUNCTIONAL DOOR HANDLE [BY OTHERS] FROM LANDING VIEW  
3X HINGES (SPRING HINGES OR DOOR CLOSER ON HYDRAULIC ELEVATOR AND VPL UNITS)

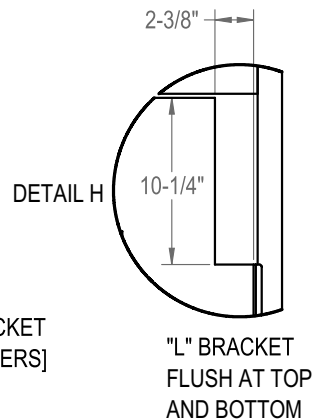

# Flush wood door instructions for contractors (cont.)

## FLUSH DOOR MADE USING DOOR SPACER

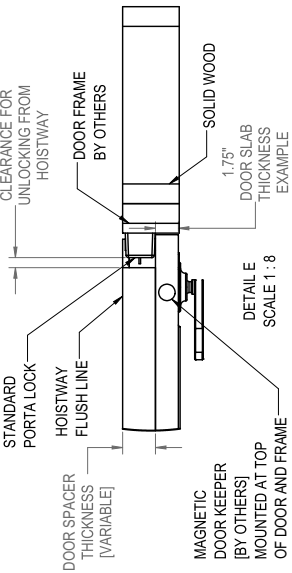

EXAMPLE SHOWN - PLEASE REFER TO FIELD MEASUREMENTS

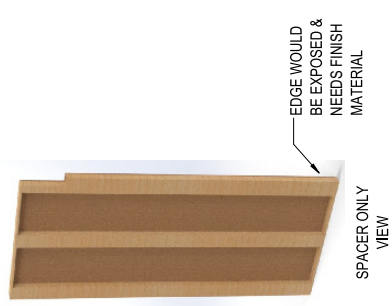
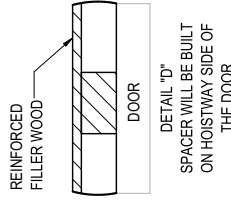

**WARNING:** Lock cut-out in top corner representative of a standard 80" door. For taller doors, such as 84" to 96", the top of the cut-out itself needs to stay at 80" from the ground to allow users access to unlock in case of emergency.

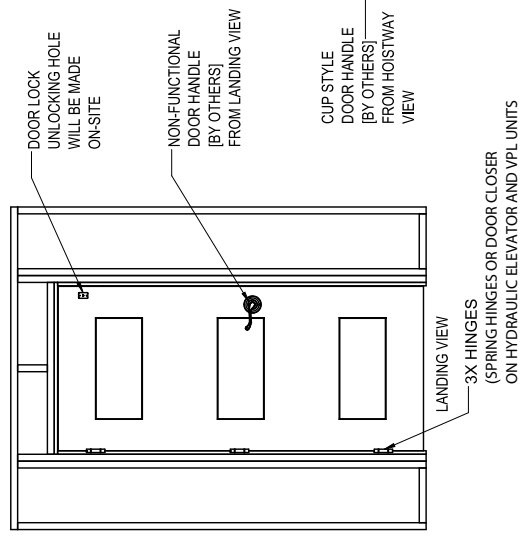
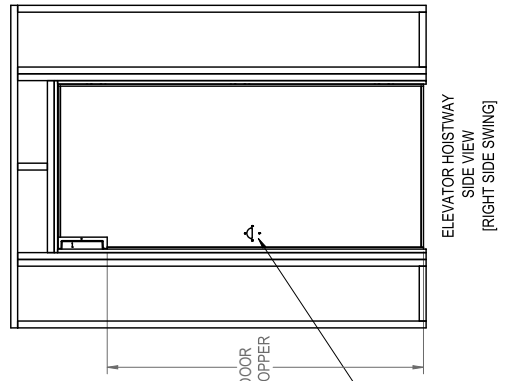
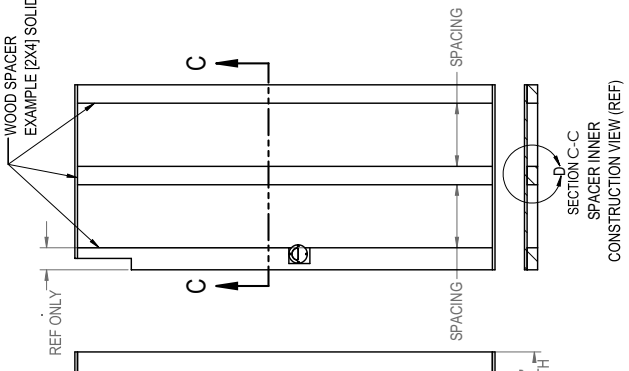
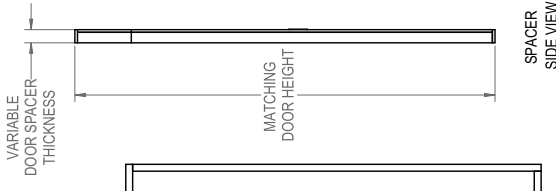
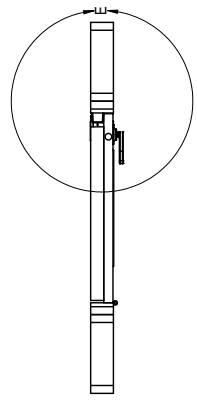

**Flush wood door instructions for contractors (cont.)**

**LOCK CUTOUT DIMENSIONS: FLUSH PORTA  
LOCK BRACKET**

**WARNING:** Lock cut-out in top corner representative of a standard 80" door. For taller doors, such as 84" to 96", the top of the cut-out itself needs to stay at 80" from the ground to allow users access to unlock in case of emergency.

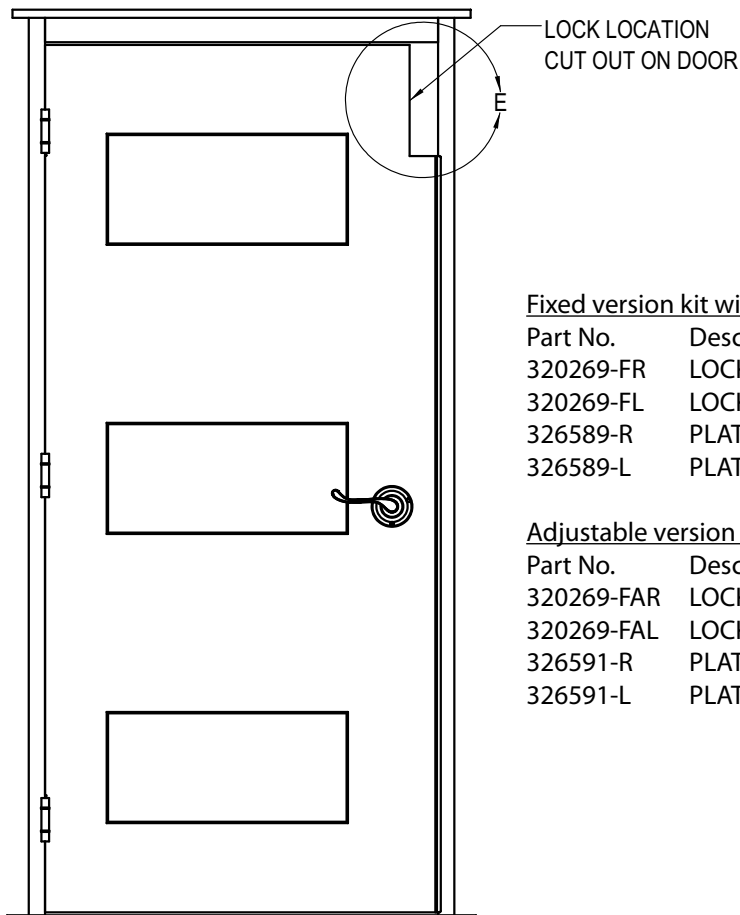

Fixed version kit with lock

Part No.	Description
320269-FR	LOCK_PORTA WOOD DR FLSH, RH ASSY
320269-FL	LOCK_PORTA WOOD DR FLSH, LH ASSY
326589-R	PLATE ONLY, RH
326589-L	PLATE ONLY, LH

Adjustable version kit with lock

Part No.	Description
320269-FAR	LOCK_PORTA WOOD DR FLSH, RH ASSY
320269-FAL	LOCK_PORTA WOOD DR FLSH, LH ASSY
326591-R	PLATE ASSEMBLY ONLY, RH
326591-L	PLATE ASSEMBLY ONLY, LH

**LOCK BRACKET OPTIONS:**

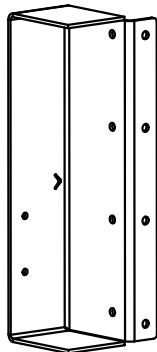

OPTION-1  
FOR 1-3/4" DOOR  
THICKNESS

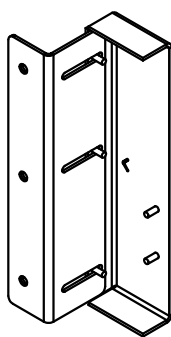

OPTION-2  
2 PIECES LOCK  
BRACKET FOR 1-1/2" - 2"  
DOOR THICKNESS

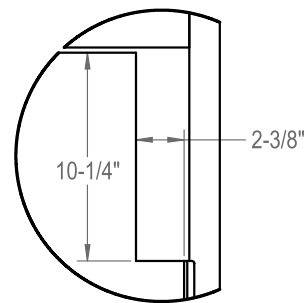
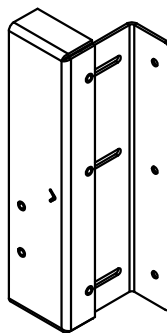

DETAIL E  
SCALE 1 : 8

**Find more design resources at:**

**savaria.com**

[Online configurator](#)

[CAD drawings](#)

[BIM objects](#)

[SpecWizard](#)

[Continuing education calendar](#)

**Savaria Concord Lifts, Inc.**  
2 Walker Drive Brampton ON L6T 5E1 Canada

 **savaria.**  
**savaria.com**

©2023 Savaria Corporation