

Infinity & Infinity HD

**Residential
Elevator**

**Planning
Guide**

© savaria.

Applicable Codes:

ASME A17.1/CSA-B44

Safety Code for Elevators and Escalators

Section 5.3 – Private Residential Elevators

IMPORTANT NOTICE

This Planning Guide provides nominal dimensions and specifications useful for the initial planning of a project. Before beginning actual construction, make sure you have the installation (shop) drawings customized with specifications and dimensions for your specific project.

Lift configurations and dimensions are in accordance with our interpretation of the standards set forth by the codes listed on the front cover of this Planning Guide. Please consult Savaria or the authorized Savaria dealer in your area for more specific information pertaining to your project, including any discrepancy between referenced standards and those of any local codes or laws.

The dimensions and specifications in this Planning Guide are subject to change (without notice) due to product enhancements and continually evolving codes and product applications.

Visit our website www.savaria.com for the most current Infinity drawings and dimensions.

Purpose of this guide

This planning guide is designed to assist architects, contractors and lift professionals in planning for an Infinity/Infinity HD Residential Elevator to meet the requirements of the following codes:

- ASME A17.1/CSA B44 2000, Section 5.3
- ASME A17.1/CSA B44 2004, Section 5.3
- ASME A17.1 2004, Addendum 2005, Section 5.3
- ASME A17.1/CSA B44 2007, Section 5.3
- ASME A17.1/CSA B44, Addendum 2008, Section 5.3
- ASME A17.1/CSA B44 2010, Section 5.3
- ASME A17.1/CSA B44 2013, Section 5.3
- ASME A17.1/CSA B44 2016, Section 5.3
- ASME A17.1/CSA B44 2019, Section 5.3
- ASME A17.1 1996, Part 5

We strongly recommend that you contact the code authority having jurisdiction in the area where the lift will be installed to become familiar with all the legal requirements governing the installation and use of lifts in commercial applications. It is extremely important for you to know and adhere to all regulations pertaining to the installation and use of lifts.

How to use this guide

- 1 Determine your client's intended use of the lift.
 - 2 Determine the local code requirements.
 - 3 Determine the site installation parameters.
 - 4 Determine the cab type and hoistway size requirements.
- NOTE:** If the Infinity/Infinity HD also has Auto Slim Doors, refer to Appendix A.
- 5 Plan for machine room and electrical requirements.

Revision History

- January 10, 2011 - Initial release
- February 23, 2011 - Added note to step 4 above, under “How to use this guide”; Added “Auto slim doors” to “Options” in specification table on page 5; Added IMPORTANT note on page 10 and pages 12 through 23; Condensed drawings to two per page to reduce book size (pages 12 through 23); Added Appendix A with Auto Slim Doors planning information
- April 19, 2011 - Updated Auto Slim Door entrance assembly and elevation drawings in Appendix A
- August 12, 2011 - Revised Auto Slim Door entrance assembly drawings in Appendix A
- September 15, 2011 - Revised Auto Slim Door entrance assembly drawings in Appendix A
- August 30, 2012 - Revised Auto Slim Door elevation and plan view drawings in Appendix A
- November 6, 2012 - Added door recommendation on page 31
- July 9, 2013 - Added Noise Level to specifications table on page 5
- March 12, 2014 - Revised specifications table on page 5
- November 5, 2014 - Revised Applicable Codes on page 3
- December 9, 2014 - Revised all drawings on pages 12 to 23 & Appendix A on pages 46, 48, 50, 52, 54, and 56
- May 25, 2015 - Revised tables on page 42
- August 7, 2015 - Added COP and Hall Call dimensions on pages 43 and 44
- August 31, 2015 - Revised load capacity in specs table on page 5
- September 24, 2015 - Added Daily Cycle to specs table on page 5
- March 7, 2016 – Removed copyright from cover page; Savaria Corporation back to Savaria Concord Lifts, Inc.
- January 25, 2017 – Added new code on page 3; Revised specs table on pages 4 and 5; Added safety rules on pages 6 to 9
- February 9, 2017 – Added spec for distance between landings to specs table on page 4
- February 26, 2018 – Removed blank pages at end
- July 12, 2018 – Added Appendix B with Bi-fold Doors planning information
- October 11, 2018 – Revised pages 4 and 47 to show 5 HP only
- April 1, 2019 – Revised HD221 to HD222 in table on page 47
- April 22, 2019 – Removed reference to “vaness” on pages 52, 54, 56, 58, 60, 62 and 68
- June 26, 2019 – Added P/N for measuring tool on page 8
- November 18, 2019 – Revised title on page 73
- November 22, 2019 – Revised specs table on page 4 (overhead) and on page 38
- January 9, 2020 – Added note to temperature spec on page 4
- January 17, 2020 – Added outdoor hall call and Savaria Link to options in spec table on page 5; Added Savaria Link option to provisions by others on page 47
- May 12, 2020 – Added new spec “floor by others (in cab)” to specs table on page 4
- May 25, 2020 – Revised Distance Between Floors in specs table on page 4
- June 17, 2020 - Added code for 2019 on page 2
- September 1, 2020 - Removed 3 & 5 rule
- October 20, 2020 - Added flush wood door instructions on pages 46 through 49
- April 8, 2021 - Updated dimensions in specifications on page 12
- August 26, 2021 - Updated picture on page 12
- September 2, 2021 - Updated plan views
- August 02, 2022 - Updated cover
- August 11, 2023 - Revised graphics from page 14-25 and 68-74
- August 15, 2023 - Revised graphics from page 27-33
- October 10, 2024 - Revised graphic on page 50, added revision number
- January 27, 2025 - Revised information on pages 4, 10 and 12

Infinity/Infinity HD specifications

Specification type	Specification data
Load capacity	Infinity: 750 lb (341 kg), 950 lb (431 kg) or 1000 lb (454 kg) Infinity HD: 1400 lb (635 kg)
Rated speed	36 ft/min (0.18 m/s) nominal
Maximum travel	50 ft (15.24 m) – confirm with local code
Maximum # of stops	6 stops
Pit depth required	Infinity: 8" (203 mm) minimum up to 96" (2438 mm) Infinity HD: 12" (305 mm) minimum up to 96" (2438 mm)
Minimum overhead clearance	92" (2337 mm) for standard 80" cab; 96" (2438 mm) for 84" cab, 108" (2743 mm) for 96" cab; 100" (2540 mm) for units with auto slim doors
Power supply (circuit to be supplied by others) NOTE: Amperage may vary depending on individual units. Verify requirements prior to installation of power supply.	North American: 208 volt, three-phase, 30 amps, 60 Hz or 230 volt, single-phase, 30 amps, 60 Hz NOTE: 60 Amps for Infinity HD International: 220 volt, single-phase, 40 amps, 50 Hz
Lighting supply (circuit to be supplied by others)	North American: 115 volt, 60 Hz, 15 amps International: 220 volt, 50 Hz 15 amps
Motor	Infinity: 5 HP (3.73 kW) Infinity HD: 5 HP (3.73 kW)
Drive system	1:2 cable hydraulic
Control system	Automatic user interface Solid state electronics with relay logic motor controls
Distance between floors	7" (178 mm) minimum (floors 1 to 2, 3 to 4, 5 to 6) 11" (279 mm) minimum (floors 2 to 3, 4 to 5)
Temperature operating range (environment)	18°C to 25°C(64.4°F to 77°F) NOTE: For optimal running conditions, each landing of the unit should be in a climate-controlled environment.
Noise level (for typical installation)	74.0 dBA; measured at a height of 1m, distance of 1m, in front of tank, in closed machine room
Daily cycle	Normal: 30 Heavy: 75 Excessive: 100 Maximum starts in 1 hour on standard installation: 15 NOTE: Please consult your Sales Representative if there a chance you may exceed these amounts.
Cab size	Infinity Type 1L, 1R, 2, 3, 4, and 5: • 36" x 48" (914 mm x 1219 mm) • 36" x 54" (914 mm x 1372 mm) • 36" x 60" (914 mm x 1524 mm) • 40" x 54" (1016 mm x 1372 mm) Infinity HD Type 1L, 1R, 2, 3, 4 and 5: • 48" x 60" (1219 mm x 1524 mm)
Floor by others (in cab)	3/4" (19 mm) maximum
Cab panel finish	Solid melamine or MDF panels (standard) Unfinished veneer (optional) Solid hardwood raised panels (optional)
Hall call station and control panel finish	Clear or bronze anodized aluminum (standard) Stainless steel or brass or architect white (optional) Rectangular (standard) or oval (optional) hall stations, keyless (standard) or keyed (optional) Alpha-numeric button marking (optional)

Infinity/Infinity HD specifications

Specification type	Specification data
Standard features	Automatic cab on/off lighting Recessed gate pocket Digital display in car operating panel Clear or bronze or black anodized aluminum cab entrance trim and handrail Data plates, capacity tags and rope tags Magnetic floor selection, stopping and re-leveling Manual reset slack rope safety switch Mechanical rail shoring blocks Negative pressure switch Variable speed pressure compensated valve with manual lowering Pump run timer Modular rail sections Unfinished plywood sub-floor White ceiling with four halogen pot lights MDF cab with or without finish, melamine cab in choice of finishes Stainless steel, clear or bronze anodized aluminum cab operating panel and hall call stations
Safety features	Cab gate safety switch Pit run/stop switch and car top run/stop switch Emergency stop and alarm buttons Uninterruptible power supply (UPS)/battery back-up system for lowering, automatic gate operation (if equipped), and electrical interlock operation and lighting in the event of a power failure Upper and lower terminal limits Final limit switch Mechanical rail shoring blocks Sling: factory pre-assembled speedy sling c/w pre-set slack chain safety brake and switch
Options	Custom cab size 96" (2438 mm) high cab; 84" (2133 mm) high cab Rated speed - (50 fpm (0.250 mps) available where code permits) Accordion car gate (choice of style) Automatic gate operator Bifold doors Automatic swing landing door operator Interlocks for doors by others and Savaria landing doors (fire rated door or wood door) Keyed on/off control panel and hall stations Optional cab finishes: raised hardwood, unfinished veneer Optional fixture finishes: brass #4 finish or blackened stainless steel (handrail, cab operating panel, hall call stations); hall call stations available in rectangular or oval Telephone cabinet to match trim Automatic slim doors Digital position indicator (PI) in hall calls Hose with flow control valve (15 ft, 20 ft or 25 ft) Pipe rupture valve Buffer springs (13" pit depth minimum) Split cylinder for travel over 384" (9754 mm) Surface mount hall call for outdoor use Savaria Link remote monitoring

Safety first – 3/4 & 4 rule

The ASME A17.1-2016/CSA B44-16 Safety Code for Elevators and Escalators (**2016 AND AFTER**) mandates the following maximum hoistway door clearances (see drawing on next page):

- Clearance between the hoistway side of the landing door and the edge of the landing sill shall not exceed 0.75" (19 mm) for swing doors (shown below) and 2.25" (57 mm) for sliding doors.
- Distance between the hoistway side of the landing door or gate and the car door or gate shall not exceed 4" (102 mm). *A measuring tool for this is shown below.*
- Infinity Residential Elevator design is with a maximum 1.25" (32 mm) running clearance.

NOTE: Concrete block/masonry shafts and some commercial metal door frames often create 3/4 & 4 rule violations.

Recommendation: We recommend installation of a solid door as hollow doors do not respect the pull-out force required by code for the door locks.

IMPORTANT

- If the landing door has a pattern on the hoistway side, measure the 3/4" setback from the deeper part of the door to the landing sill.
- For accordion (panel fold) gates, you **MUST** have flush doors (not the 3/4" setback).
- 3/4" setback is possible only when the car doors are bifold or slim doors.

Measuring tool for accordion car gate and landing door (3/4 & 4 rule)



Measuring Tool P/N 301803

With the measuring tool pressed into the "V" of the accordion car gate, the hoistway side of the landing door must not be more than 4" (102 mm) as shown.

3/4 & 4 rule

3/4" & 4" rule

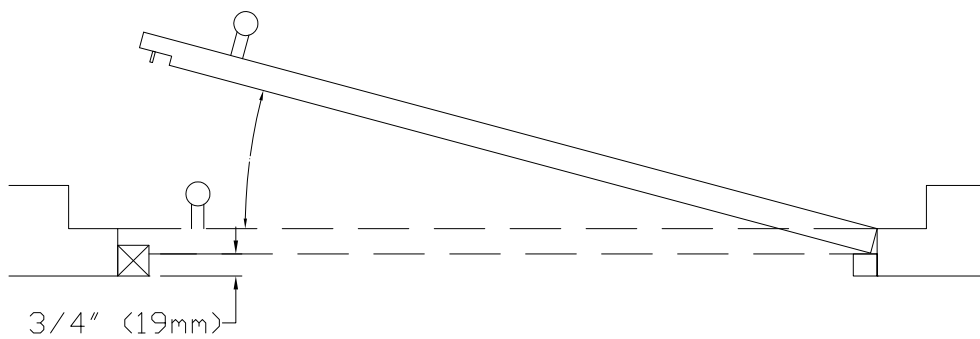
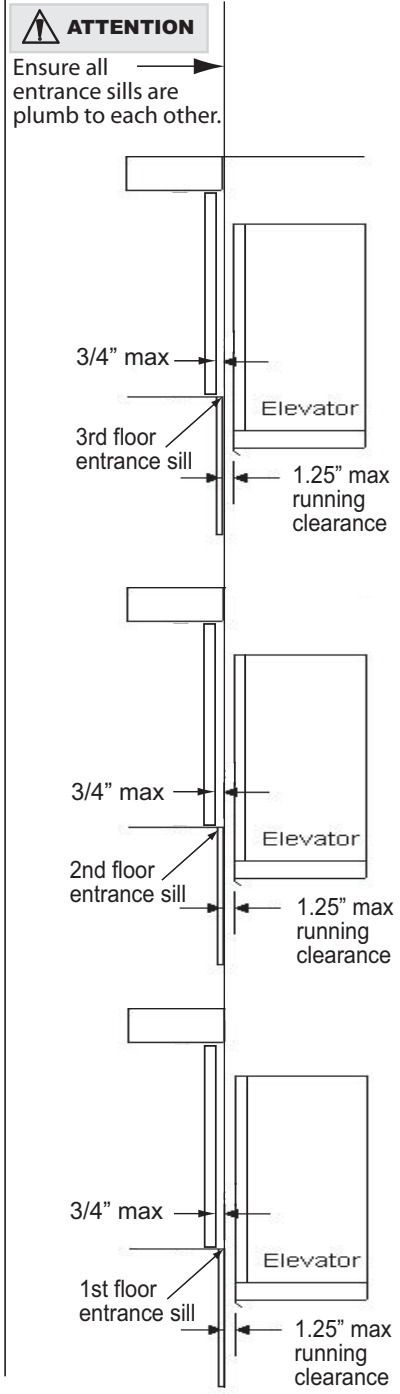
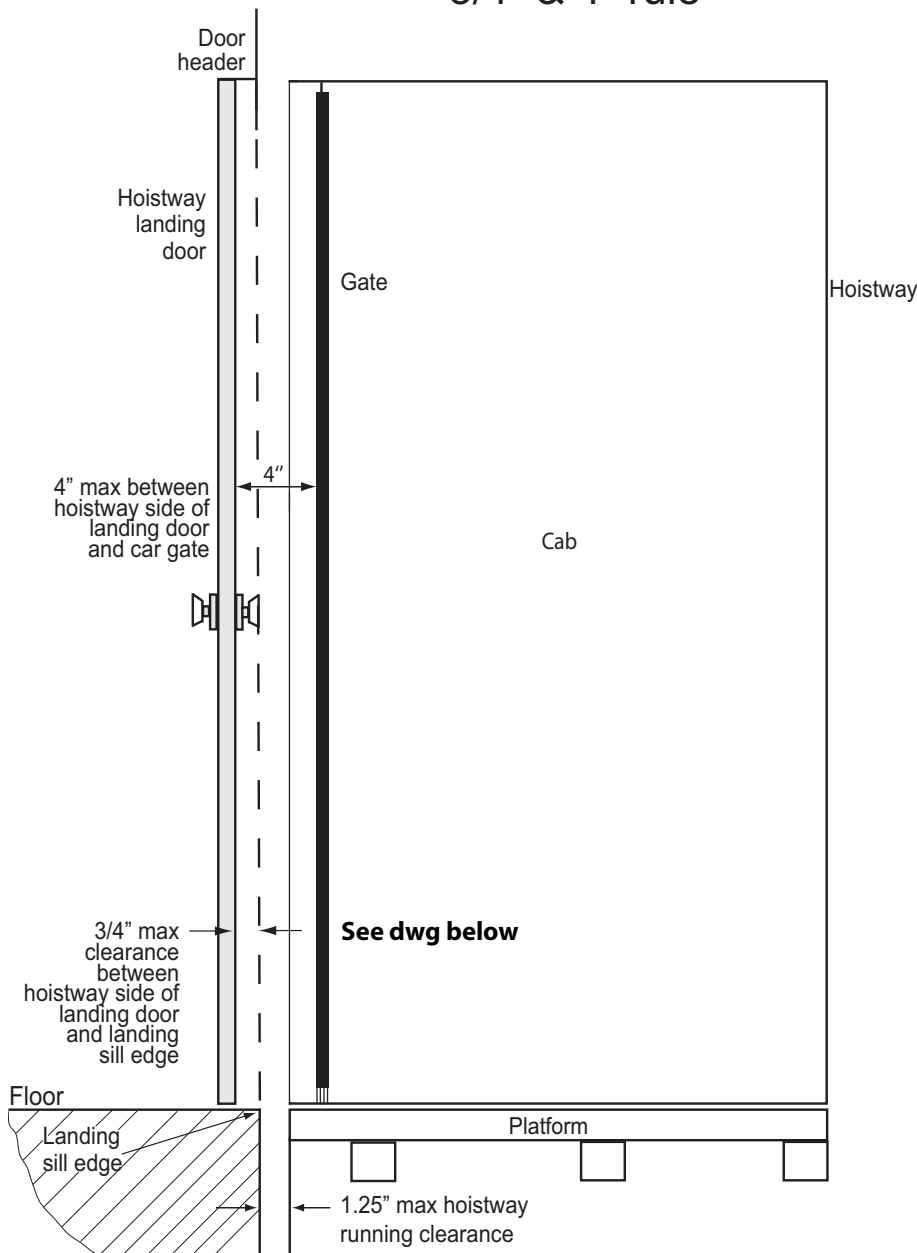

Product description

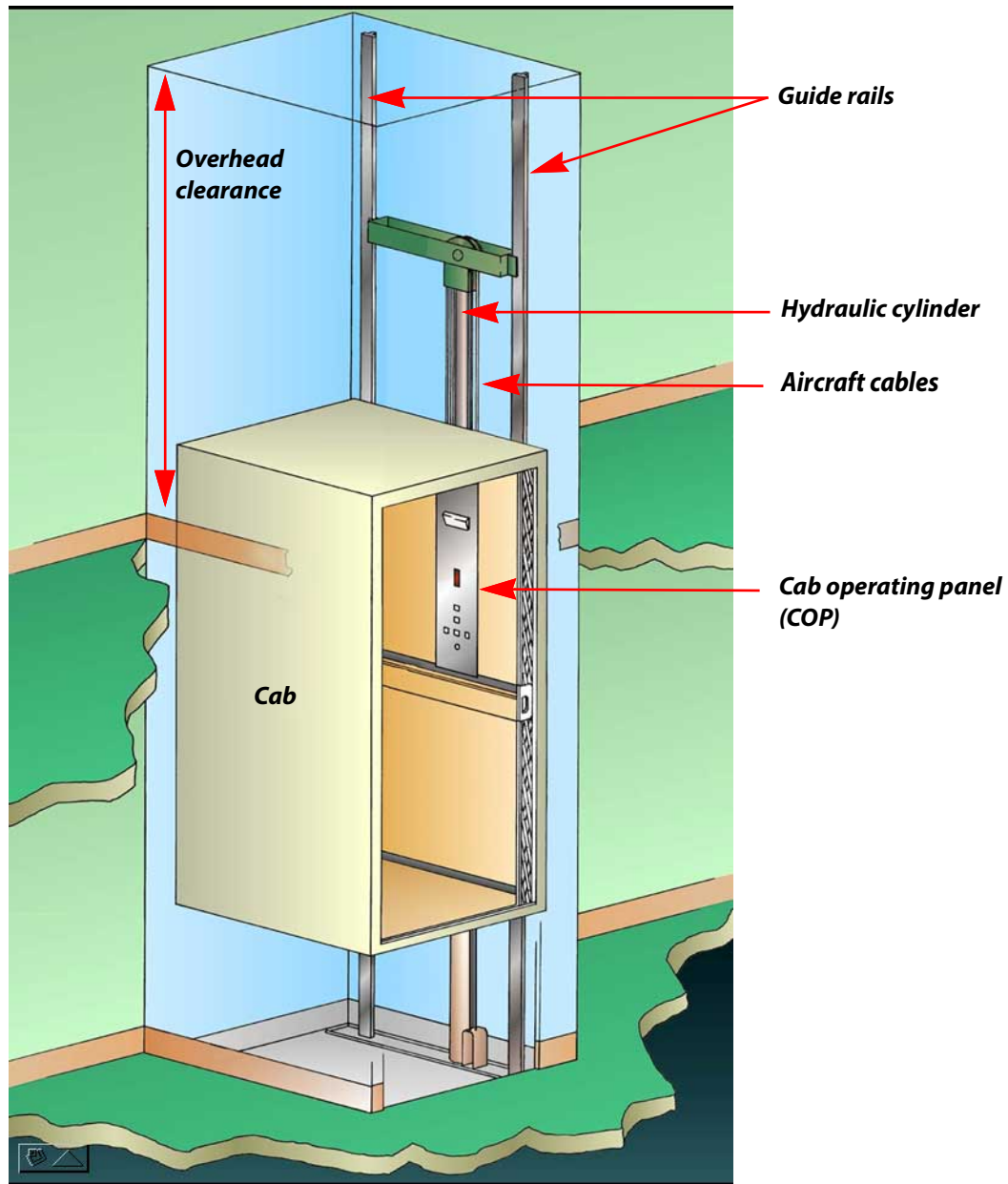

INFINITY IN HOISTWAY

Meets Americans with Disabilities Act (ADA) requirements

The Infinity and Infinity HD meet the requirements of the ADA Accessibility Guidelines as a means to provide public building access.

Design assistance

With over 30 years of experience, Savaria has the expertise to provide solutions to practically every design challenge you face. Please call our Customer Service Department for professional advice at (800) 661-5112 or (905) 791-5555.

Infinity/Infinity HD cab types

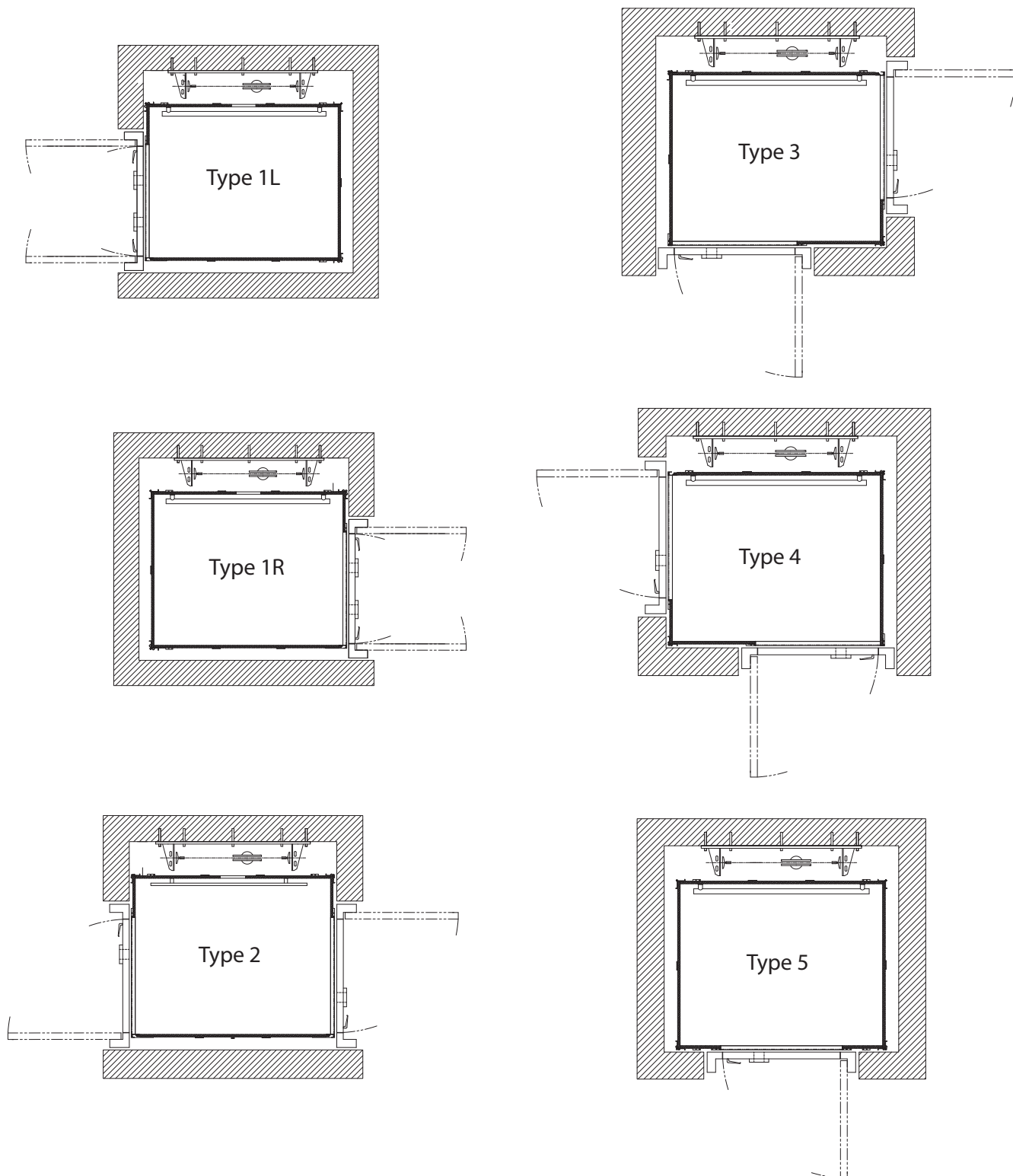

IMPORTANT

Finished hoistway dimensions must include the drywall. Determine the fire rating of the hoistway, the type and layers of sheet rock and build only off the final installation (shop) drawings specific to your project.

Machine room options

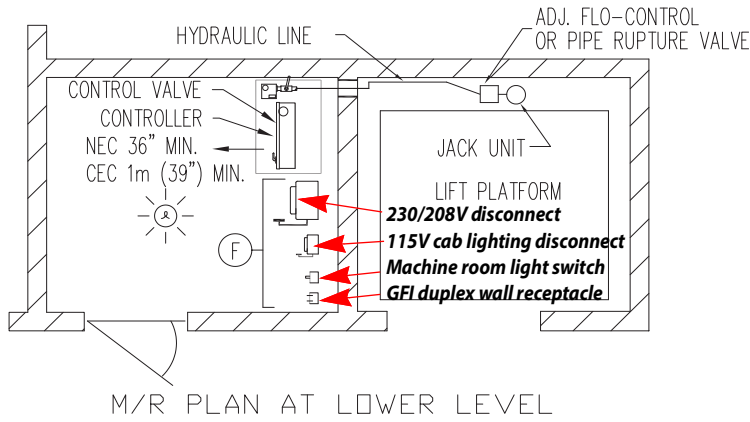

Left-hand position

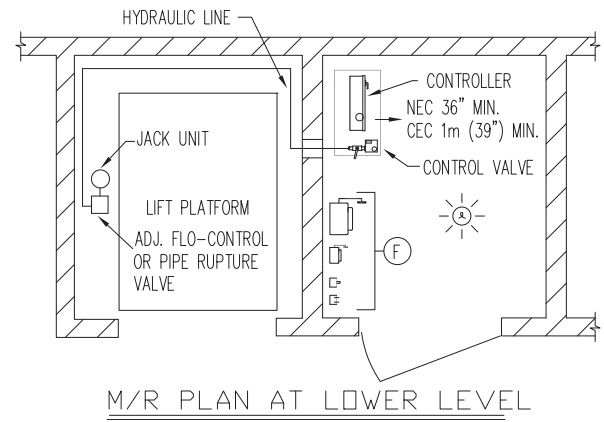

Right-hand position

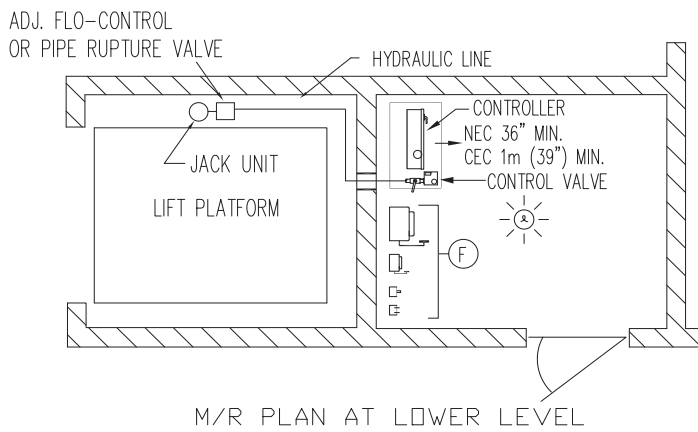

Back position

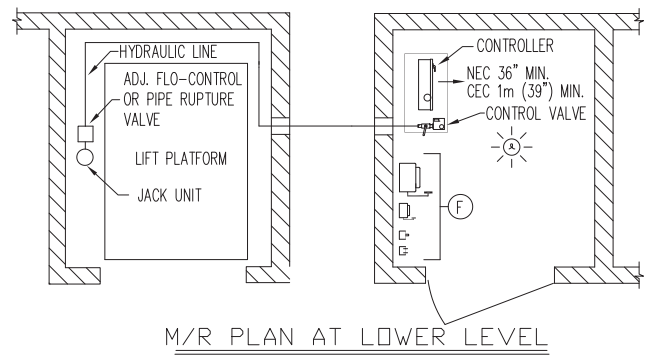

Remote position

- The machine room must be built in accordance with local, state/provincial and national codes. Adequate ventilation is required to maintain a temperature of 18°C to 25°C (64.4°F to 77°F) for output of 3600 BTU per hour.
- Power supply must be 208V three-phase with 30 amp or 230V single-phase with 40 amp dedicated circuit with equipment ground. A lockable fused disconnect with an auxiliary normally open interlock switch must be located next to the controller. The electrical circuit must terminate on the line side terminal lugs of the disconnect. It is provided and installed by others.
- The machine room lighting shall be a minimum of 19 foot candles (204 lux) at working surfaces.
- The switch for the light must be within 18" (457 mm) of the strike side of the machine room door.
- The switch, light and wiring are provided and installed by others. The light must be guarded to prevent accidental breakage of contact with the hot bulb. The switch, light, wiring and guard are provided and installed by others.
- A convenience outlet of 115V single-phase 15 amp with G.F.I. shall be located next to the light switch in the machine room (provided and installed by others).
- A telephone line circuit is to be provided and installed by others. This circuit must be connected to an outside line or a 24 hour central exchange.
- The machine room access door must be self closing, self locking with a key and spring return latch. Door and hardware are provided and installed by others. Consult local building codes for door construction.
- The machine room must be free of any pipes, wiring and obstructions not related to the operation of the lift. Provide a 4 inch conduit from the lift shaft to the remote machine room.

Machine room dimensions

IMPORTANT NOTE:
CONFIRM REQUIREMENTS WITH LOCAL CODE

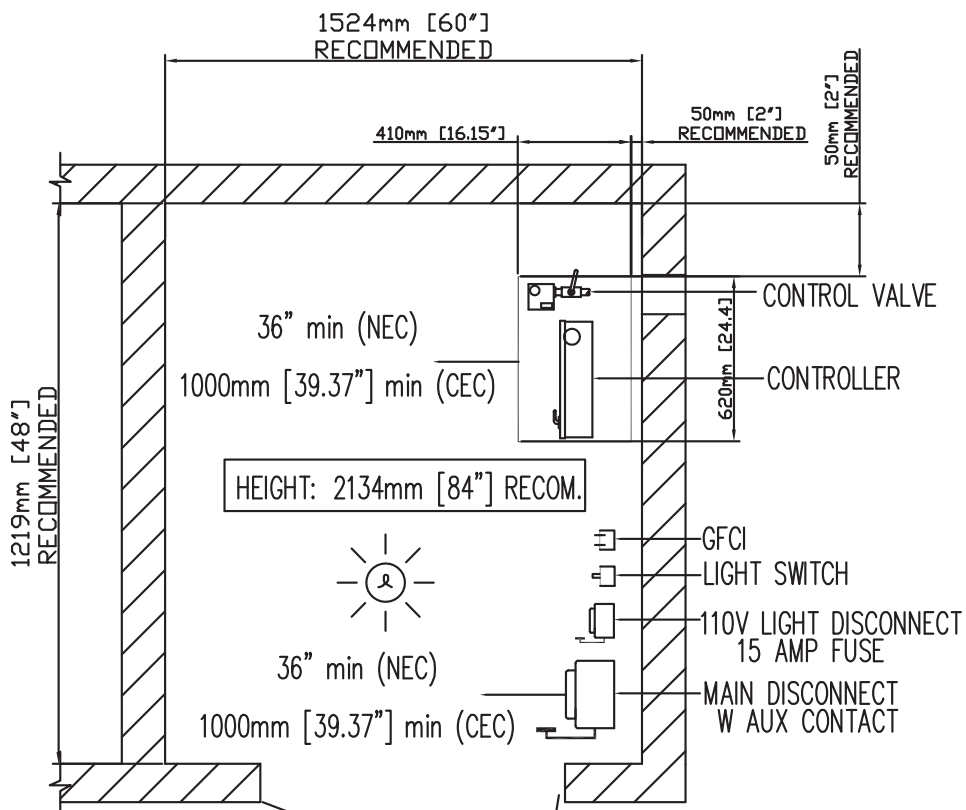

NOTE A:
POSITION OF DOORS AND COMPONENTS CAN VARY
AS LONG AS THE MINIMUM DISTANCE IN FRONT OF COMPONENTS IS RESPECTED

NOTE B:
A RACEWAY BETWEEN THE MACHINE ROOM AND HOISTWAY WILL NEED TO BE PROVIDED.
CONSULT YOUR INSTALLATION COMPANY FOR SIZE AND LOCATION

Controller tank specifications

Controller tank specifications	
Dimensions	Height: 51" (1295 mm) Width: 28" (711 mm) Depth: 17" (432 mm)
Minimum required clearance	39.37" (1000 mm)
Valve and manual lowering handle location	Inside tank
Rupture valve test	T-fitting factory installed
Tank to controller wiring	Quick connect valve and motor wiring
Controller layout	Relay board
Keyed lock to tank	Yes
Machine room required	No (with local jurisdiction approval)
Tank capacity (gal/ltr)	15-16.5 gal/57-63 ltr
Maximum dry weight (lb/kg)	147 lb/55 kg
Maximum filled weight (lb/kg)	312 lb/117 kg
Operating environment	18°C to 25°C(64.4°F to 77°F)
Operating volume	57 dBA

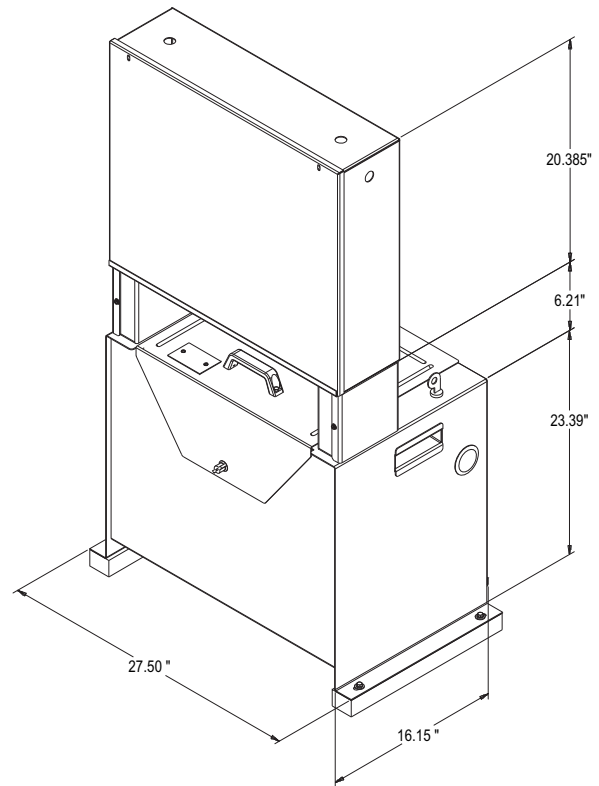

Controller tank features

- Hydraulic hose connection port on both sides of the tank
- Built-in handles on both sides of the tank
- Isolation mounting of pump motor valve assembly minimizes operating issues

Elevation view – Infinity

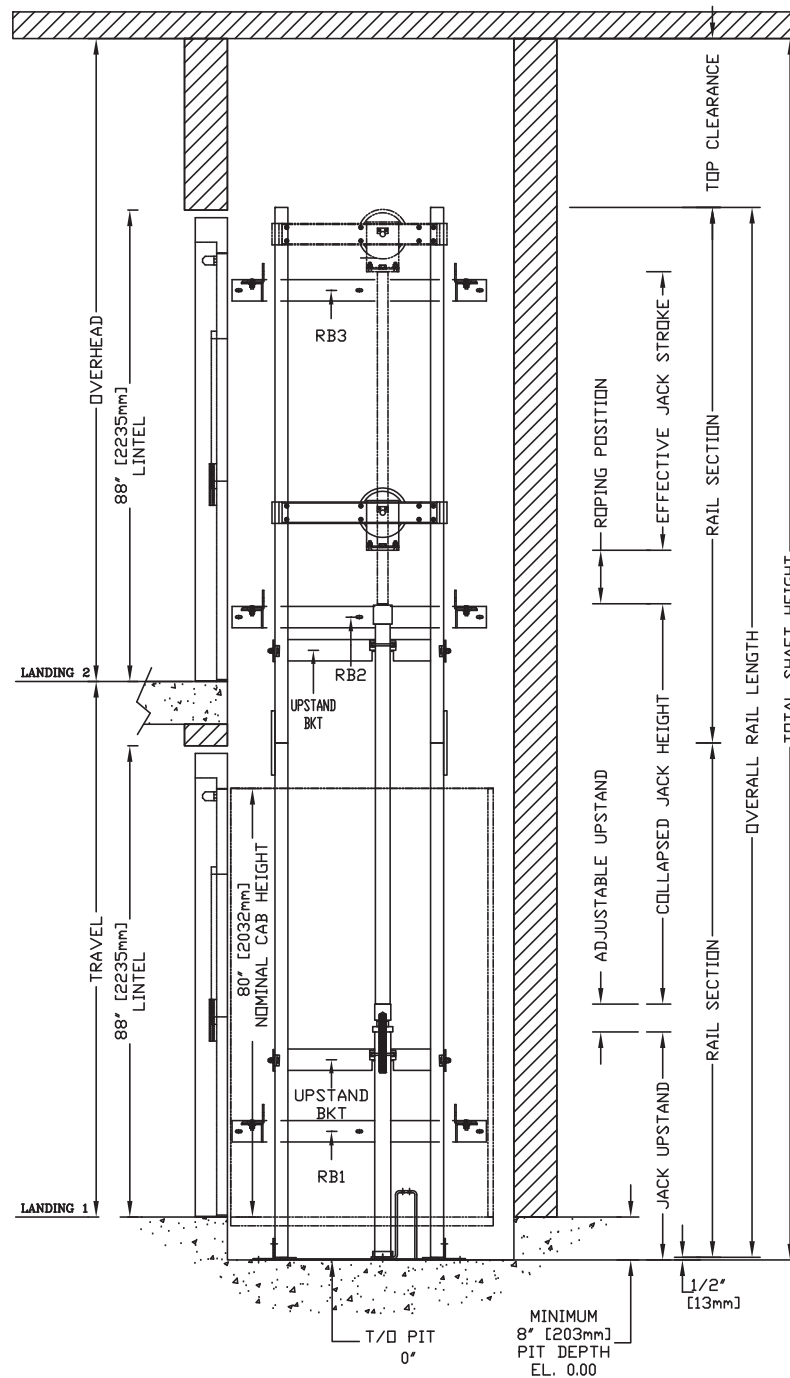

Top rail bracket (RB3): at top of hoistway (consult your Savaria representative for exact location).
 Intermediate rail bracket (RB2): 96 in (2438 mm) intervals above bottom bracket.
 Bottom rail bracket (RB1): 24 in (610 mm) above pit floor.

IMPORTANT: Always refer to your plan drawings for dimensions specific to your site.
 For Infinity with **Auto Slim Doors**, DO NOT use the above drawings; refer to **Appendix A** instead.
 For Infinity with **Bi-fold Doors**, DO NOT use the above drawings; refer to **Appendix B** instead.

Plan view – Infinity 36" x 48" type 1 left-hand

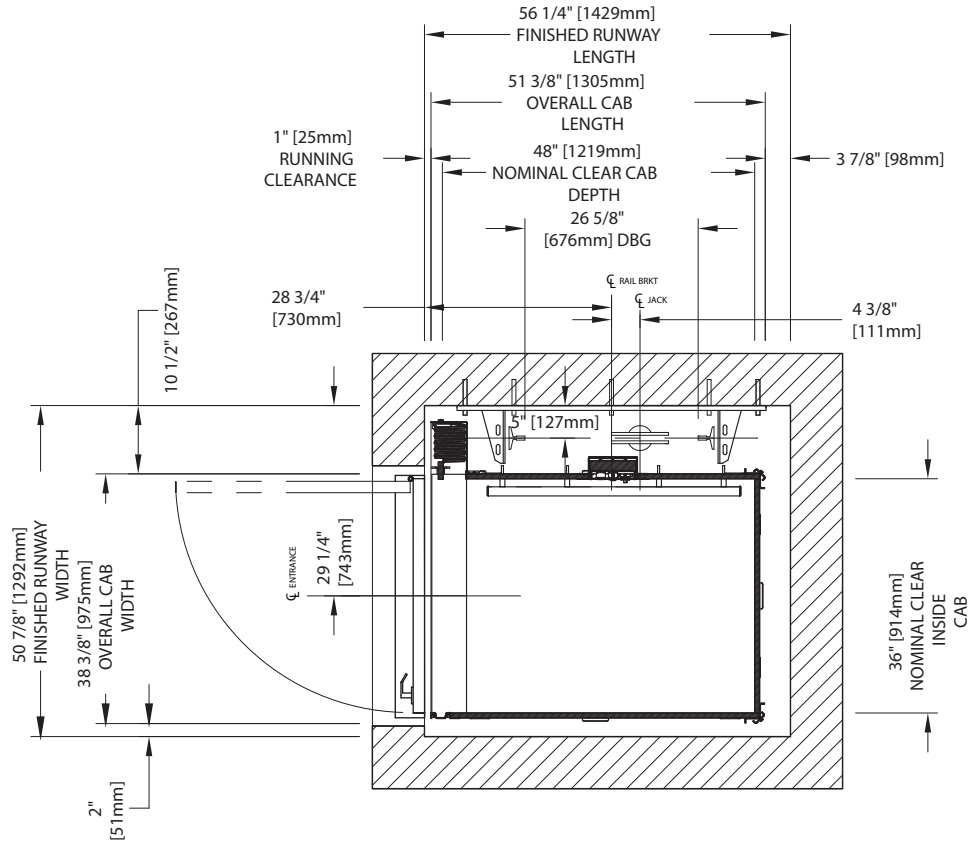

Plan view – Infinity 36" x 48" type 1 right-hand

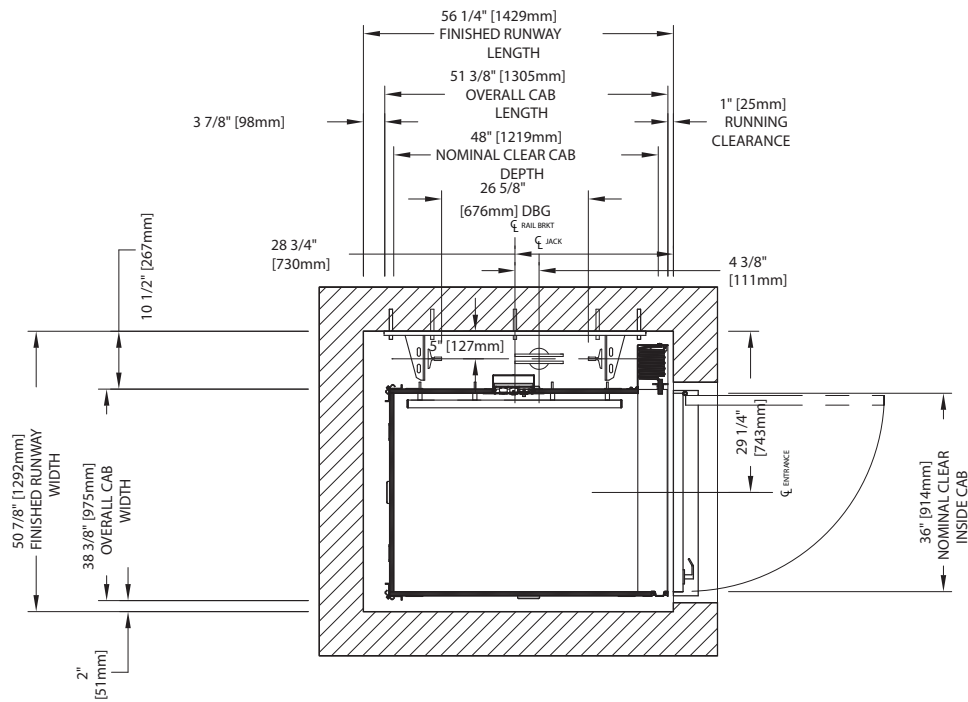

IMPORTANT: Always refer to your plan drawings for dimensions specific to your site.
 For Infinity with **Auto Slim Doors**, DO NOT use the above drawings; refer to **Appendix A** instead.
 For Infinity with **Bi-fold Doors**, DO NOT use the above drawings; refer to **Appendix B** instead.

Plan view – Infinity 36" x 48" type 2

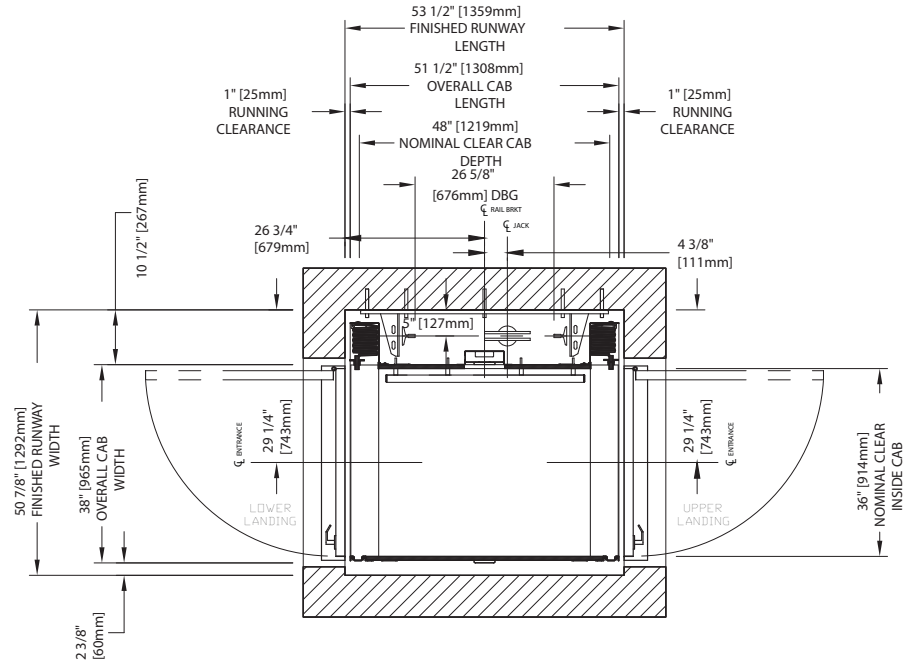

Plan view – Infinity 36" x 48" type 3

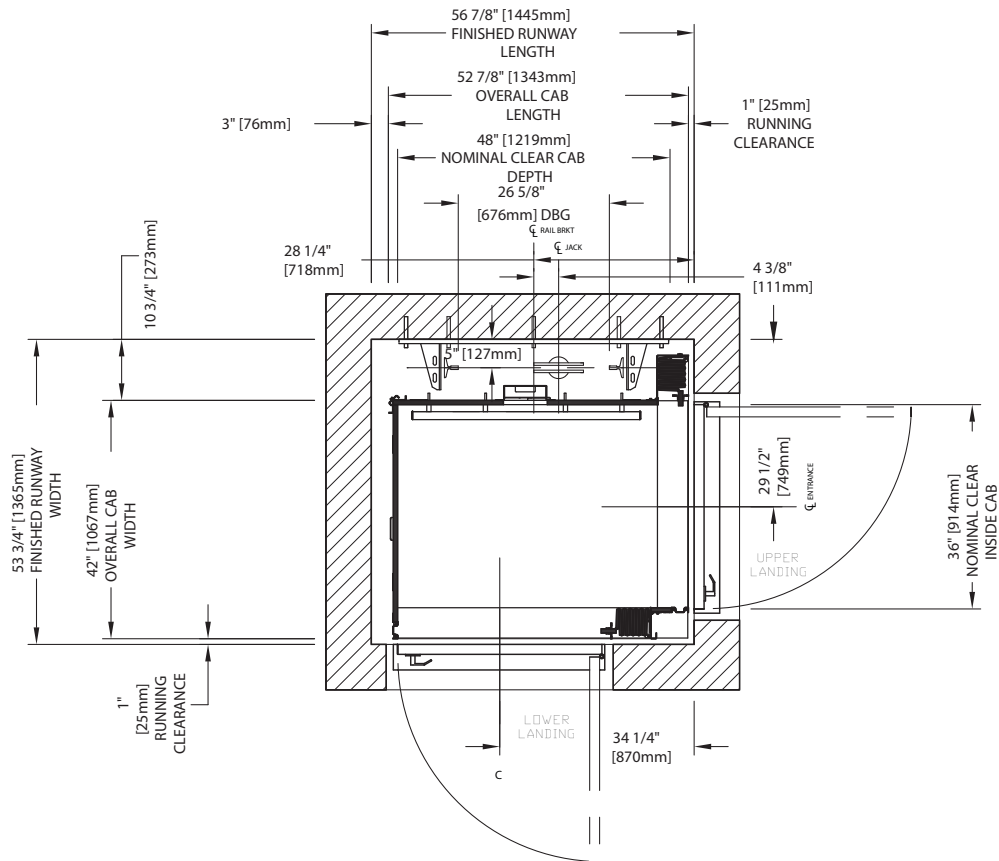

IMPORTANT: Always refer to your plan drawings for dimensions specific to your site.
 For Infinity with **Auto Slim Doors**, DO NOT use the above drawings; refer to **Appendix A** instead.
 For Infinity with **Bi-fold Doors**, DO NOT use the above drawings; refer to **Appendix B** instead.

Plan view – Infinity 36" x 48" type 4

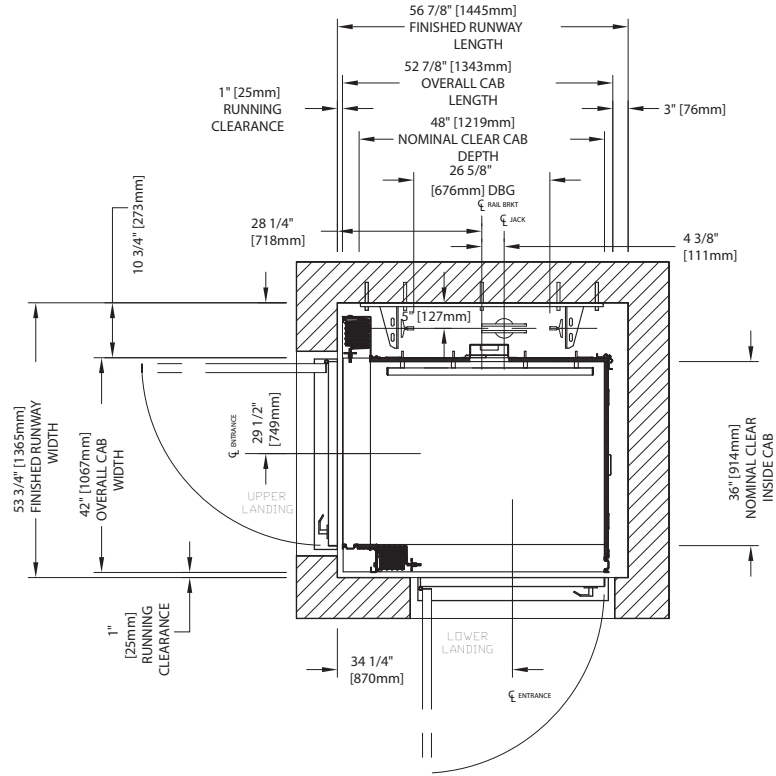

Plan view – Infinity 36" x 48" type 5

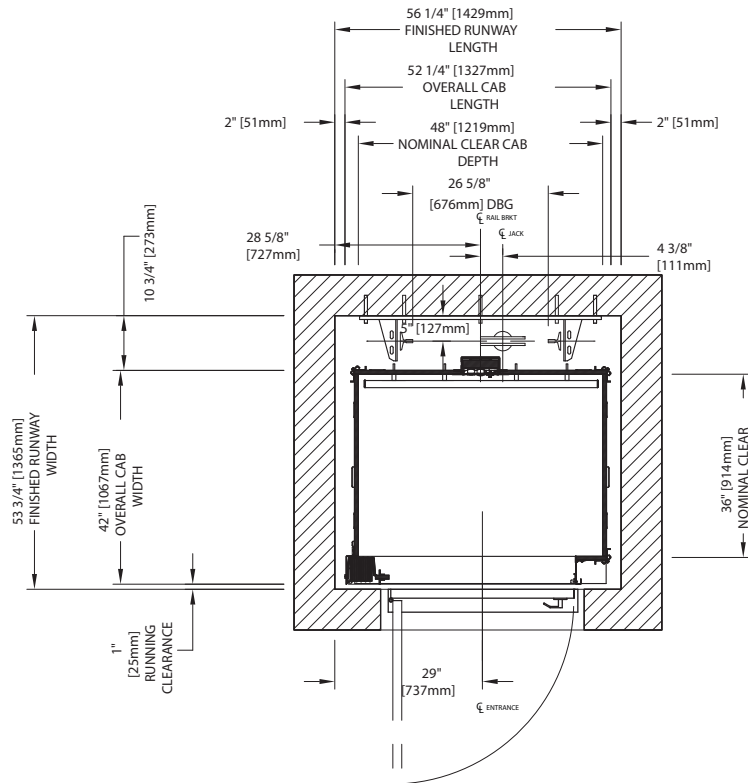

IMPORTANT: Always refer to your plan drawings for dimensions specific to your site.
 For Infinity with **Auto Slim Doors**, DO NOT use the above drawings; refer to **Appendix A** instead.
 For Infinity with **Bi-fold Doors**, DO NOT use the above drawings; refer to **Appendix B** instead.

Plan view – Infinity 36" x 54" type 1 left-hand

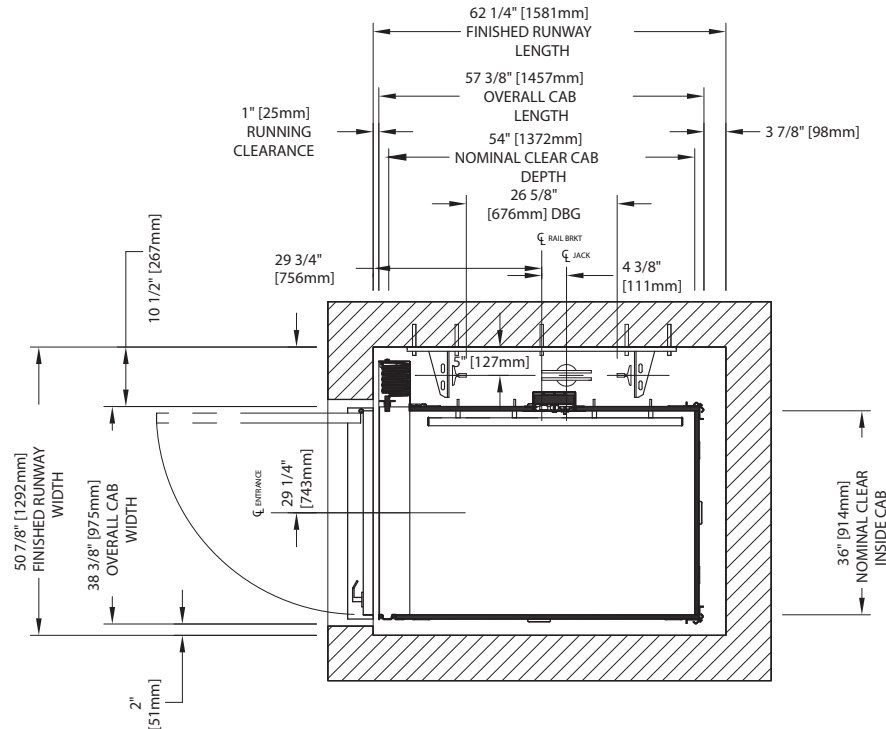

Plan view – Infinity 36" x 54" type 1 right-hand

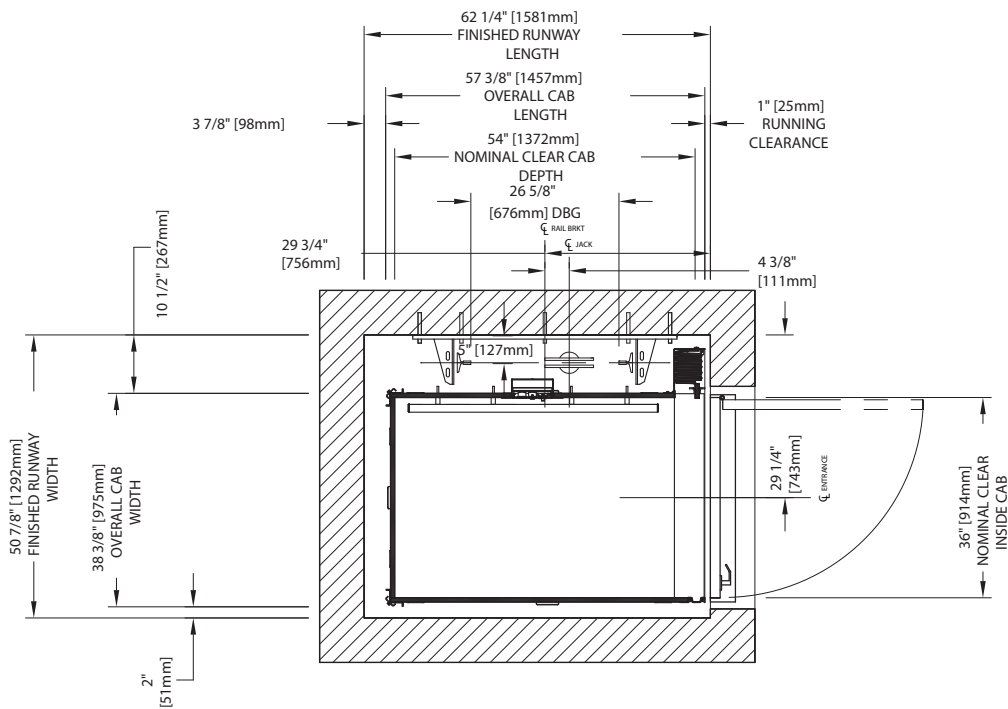

IMPORTANT: Always refer to your plan drawings for dimensions specific to your site.
 For Infinity with **Auto Slim Doors**, DO NOT use the above drawings; refer to **Appendix A** instead.
 For Infinity with **Bi-fold Doors**, DO NOT use the above drawings; refer to **Appendix B** instead.

Plan view – Infinity 36" x 54" type 2

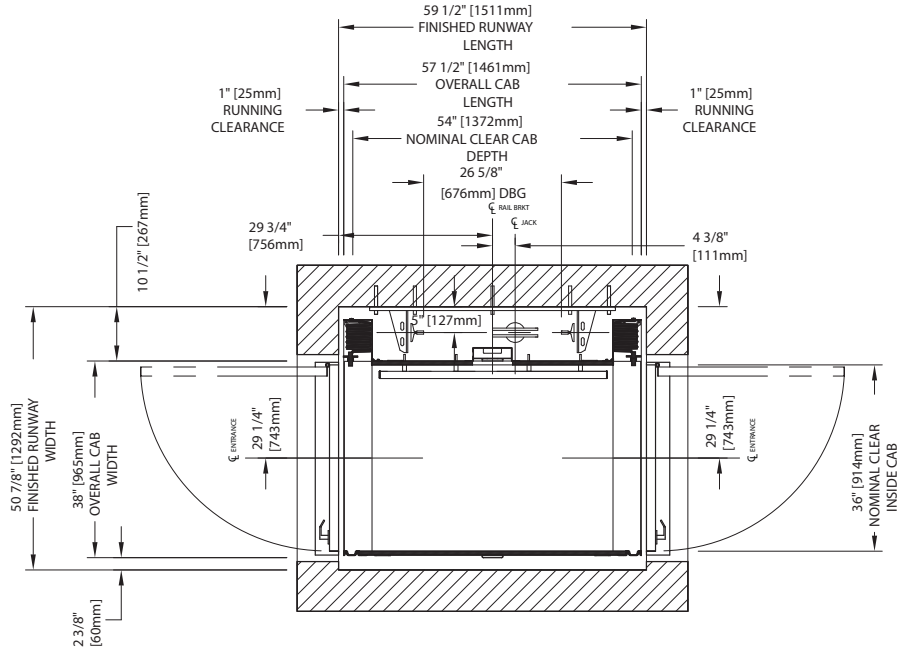

Plan view – Infinity 36" x 54" type 3

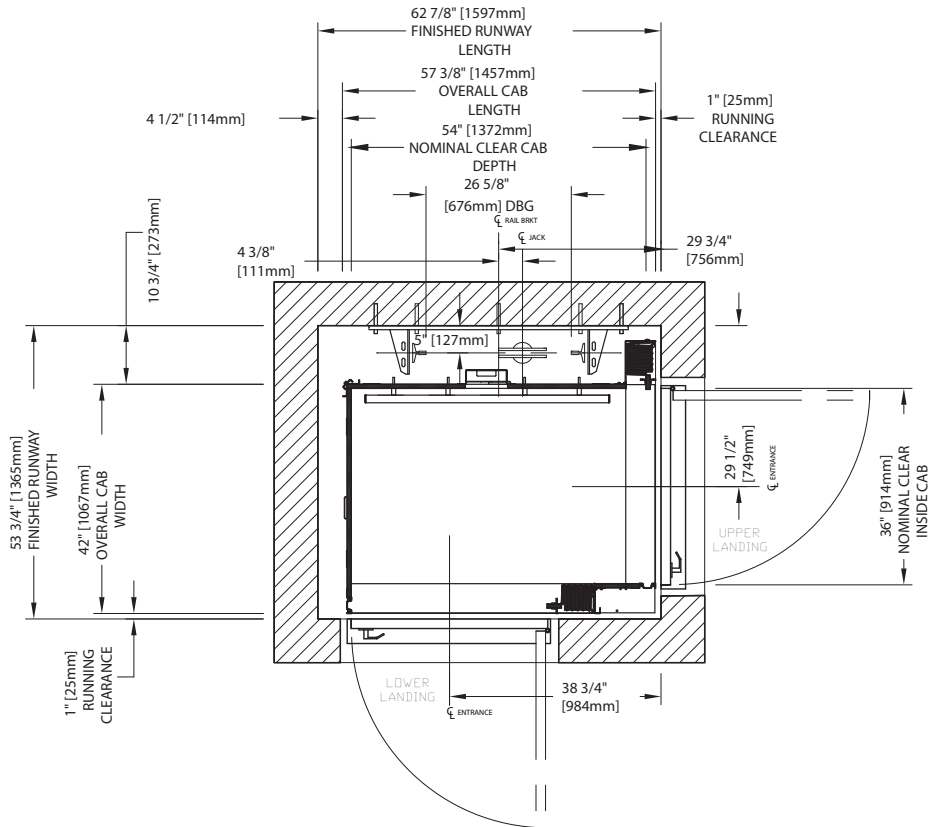

IMPORTANT: Always refer to your plan drawings for dimensions specific to your site.
 For Infinity with **Auto Slim Doors**, DO NOT use the above drawings; refer to **Appendix A** instead.
 For Infinity with **Bi-fold Doors**, DO NOT use the above drawings; refer to **Appendix B** instead.

Plan view – Infinity 36" x 54" type 4

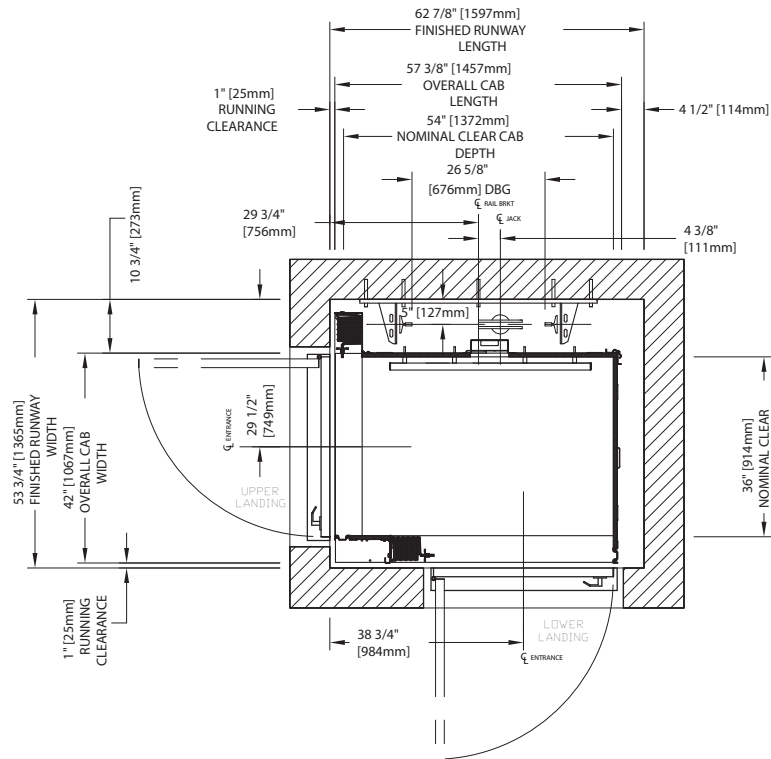

Plan view – Infinity 36" x 54" type 5

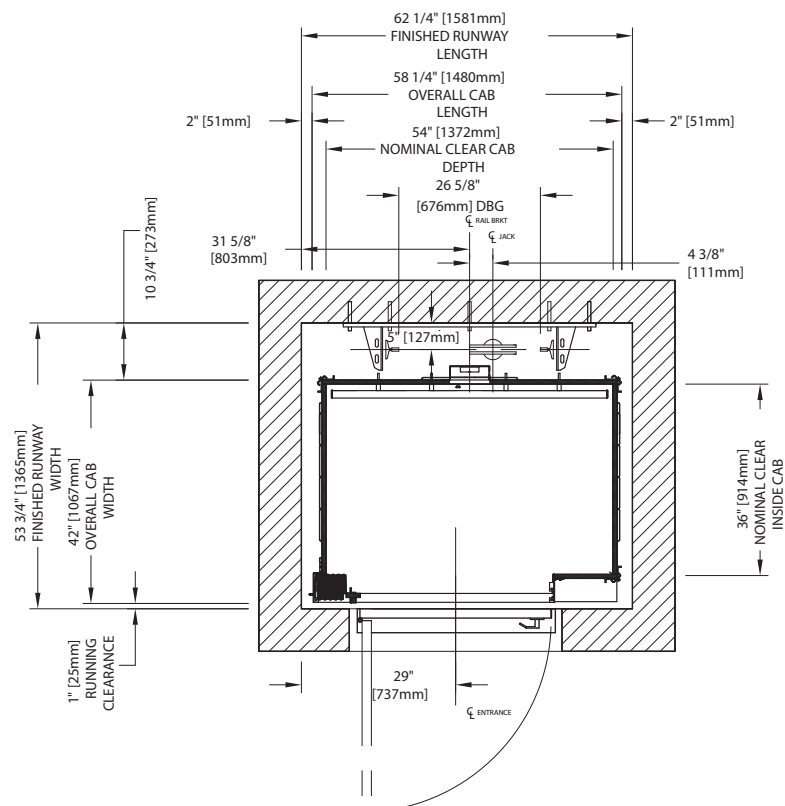

IMPORTANT: Always refer to your plan drawings for dimensions specific to your site.
 For Infinity with **Auto Slim Doors**, DO NOT use the above drawings; refer to **Appendix A** instead.
 For Infinity with **Bi-fold Doors**, DO NOT use the above drawings; refer to **Appendix B** instead.

Plan view – Infinity 36" x 60" type 1 left-hand

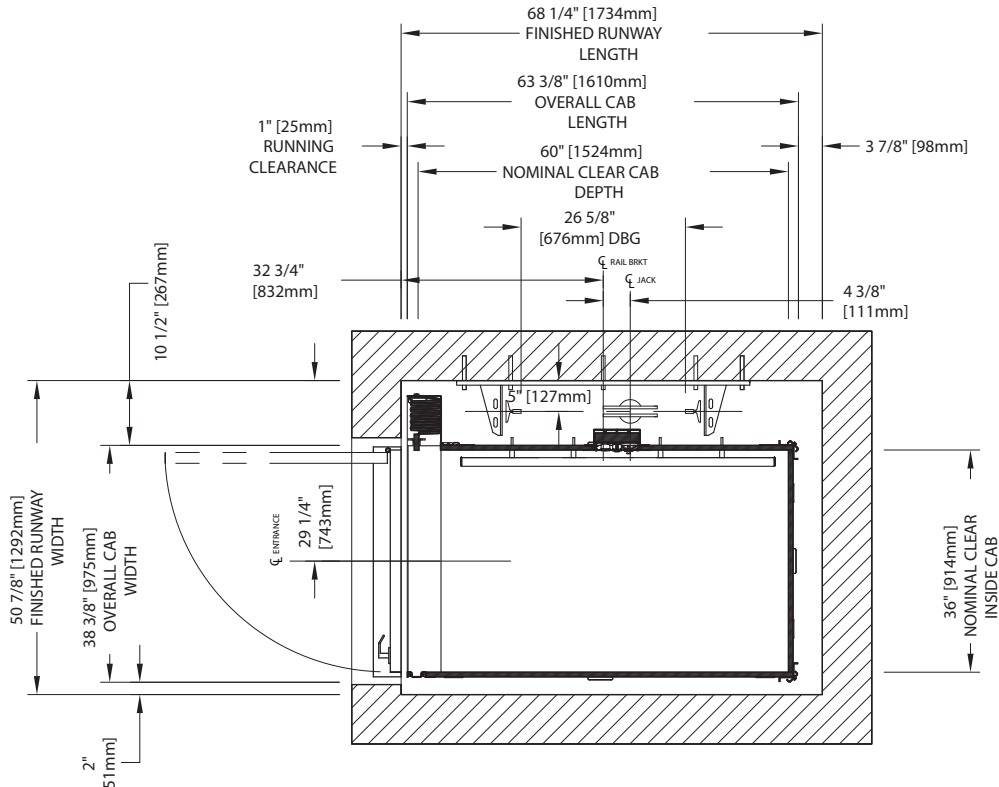

Plan view – Infinity 36" x 60" type 1 right-hand

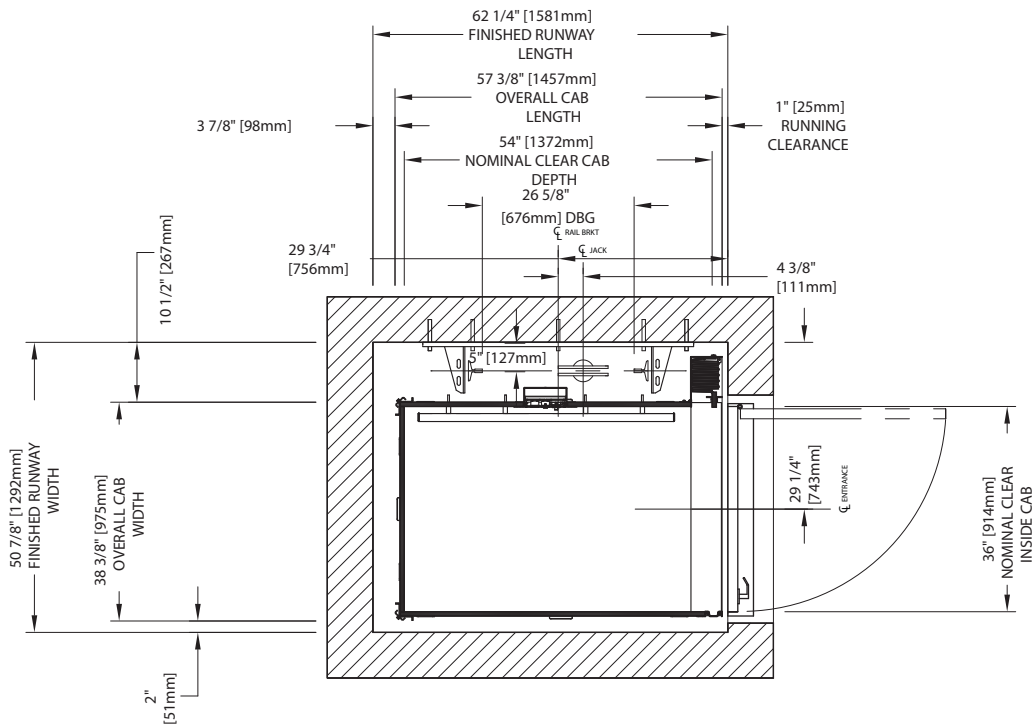

IMPORTANT: Always refer to your plan drawings for dimensions specific to your site.
 For Infinity with **Auto Slim Doors**, DO NOT use the above drawings; refer to **Appendix A** instead.
 For Infinity with **Bi-fold Doors**, DO NOT use the above drawings; refer to **Appendix B** instead.

Plan view – Infinity 36" x 60" type 2

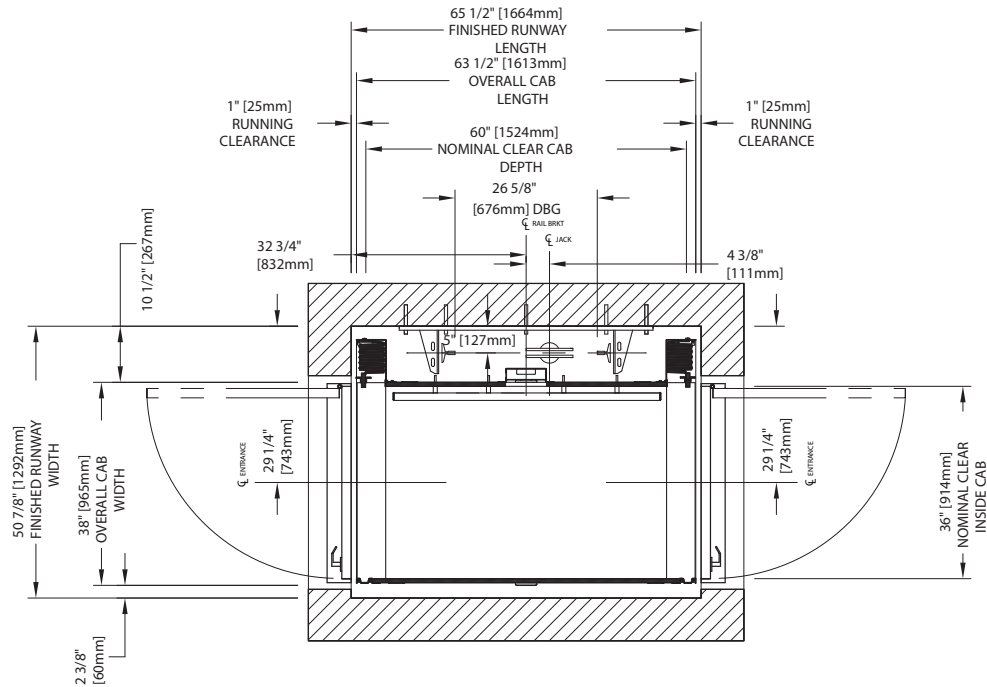

Plan view – Infinity 36" x 60" type 3

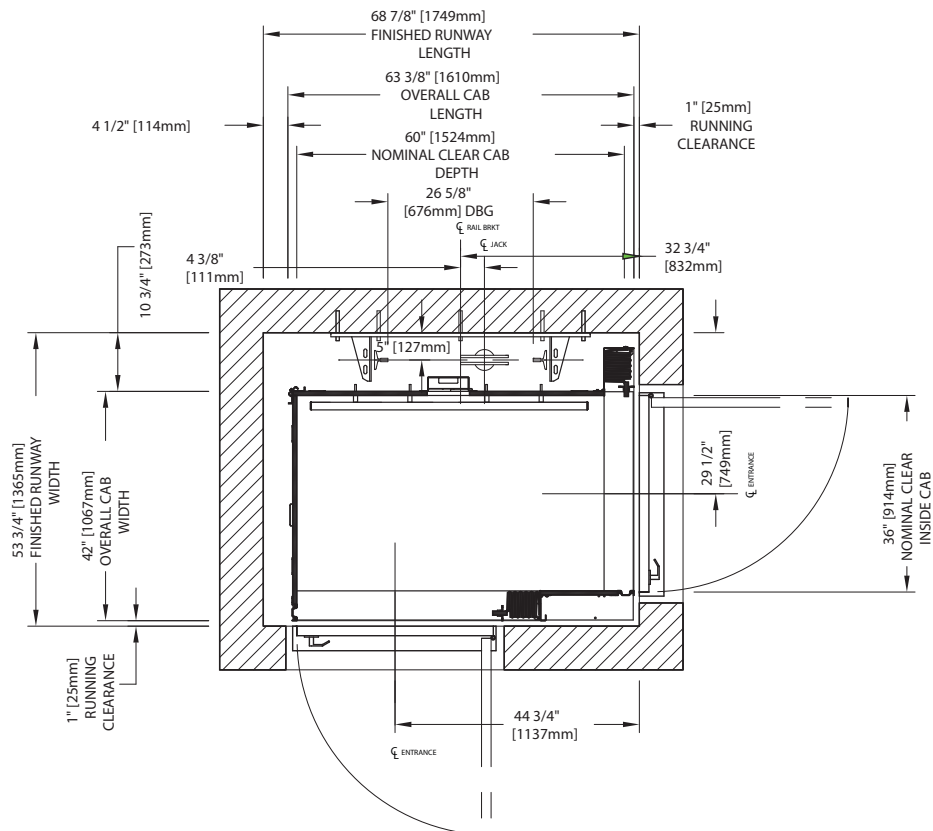

IMPORTANT: Always refer to your plan drawings for dimensions specific to your site.
 For Infinity with **Auto Slim Doors**, DO NOT use the above drawings; refer to **Appendix A** instead.
 For Infinity with **Bi-fold Doors**, DO NOT use the above drawings; refer to **Appendix B** instead.

Plan view – Infinity 36" x 60" type 4

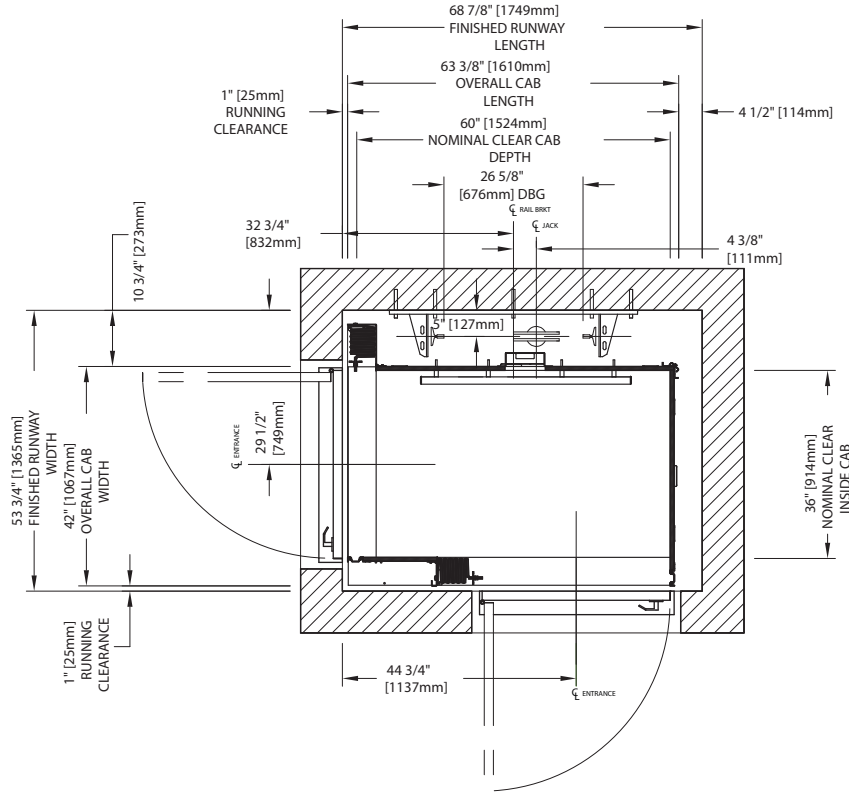

Plan view – Infinity 36" x 60" type 5

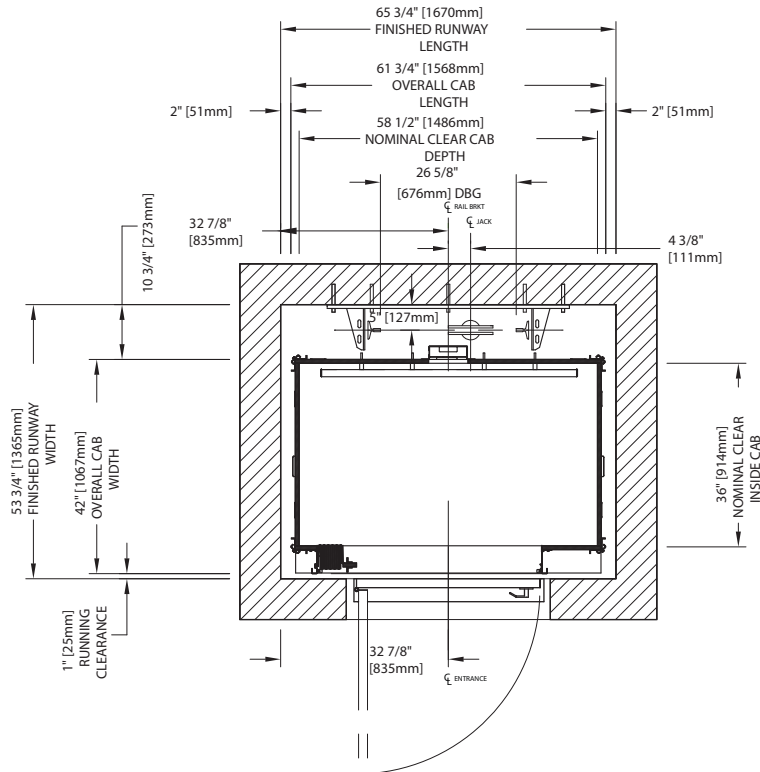

IMPORTANT: Always refer to your plan drawings for dimensions specific to your site.
 For Infinity with **Auto Slim Doors**, DO NOT use the above drawings; refer to **Appendix A** instead.
 For Infinity with **Bi-fold Doors**, DO NOT use the above drawings; refer to **Appendix B** instead.

Plan view – Infinity 40" x 54" type 1 left-hand

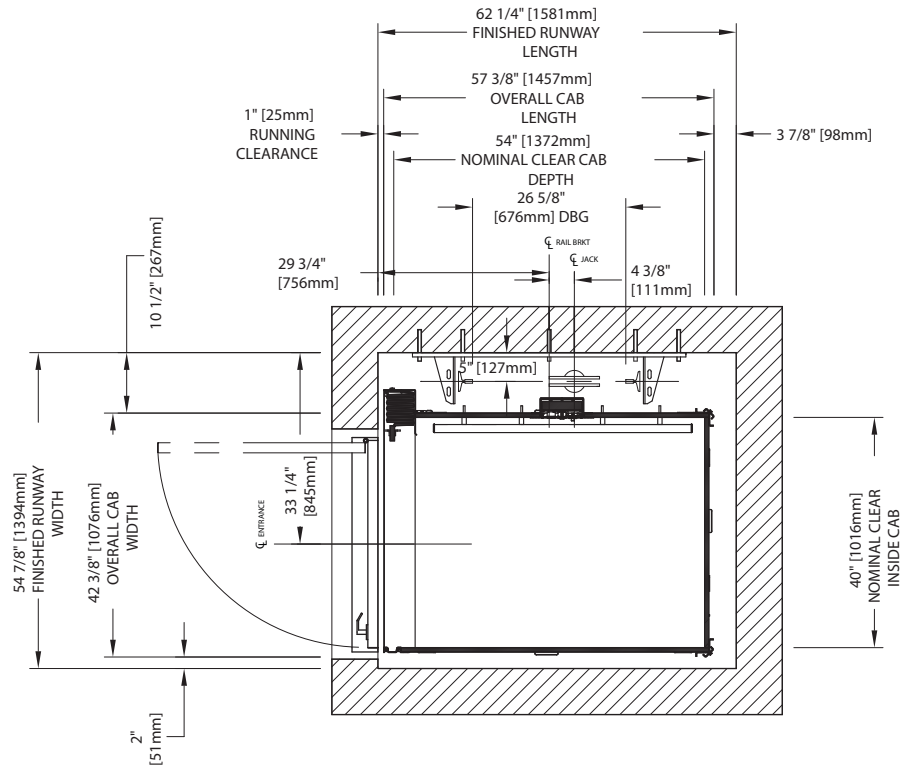

Plan view – Infinity 40" x 54" type 1 right-hand

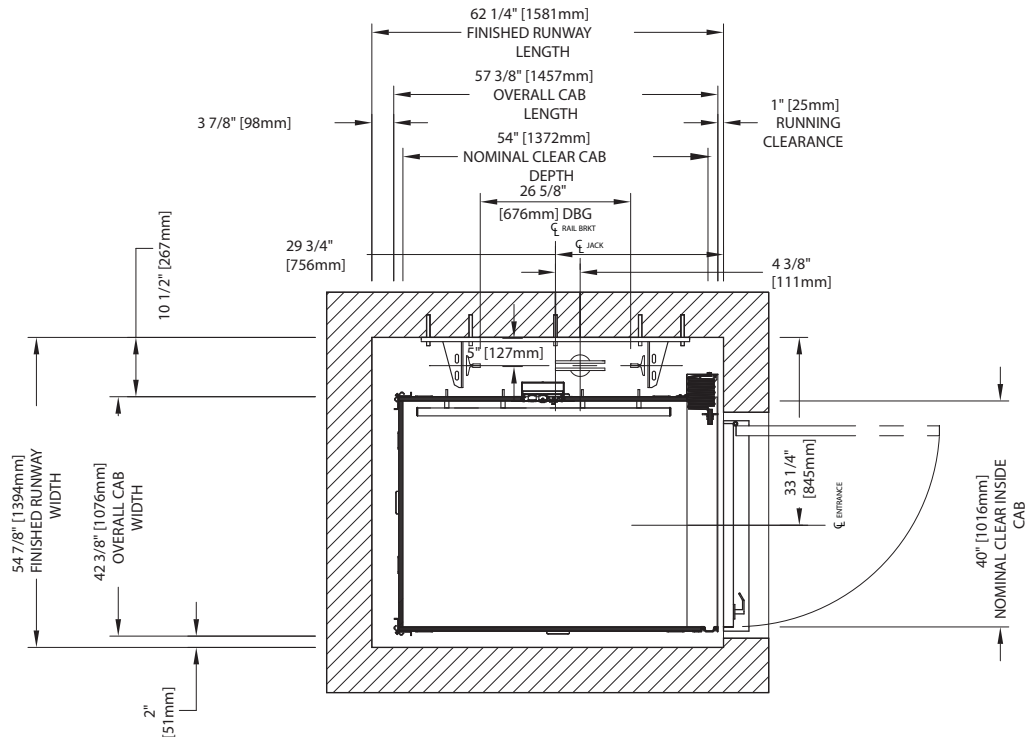

IMPORTANT: Always refer to your plan drawings for dimensions specific to your site.
 For Infinity with **Auto Slim Doors**, DO NOT use the above drawings; refer to **Appendix A** instead.
 For Infinity with **Bi-fold Doors**, DO NOT use the above drawings; refer to **Appendix B** instead.

Plan view – Infinity 40" x 54" type 2

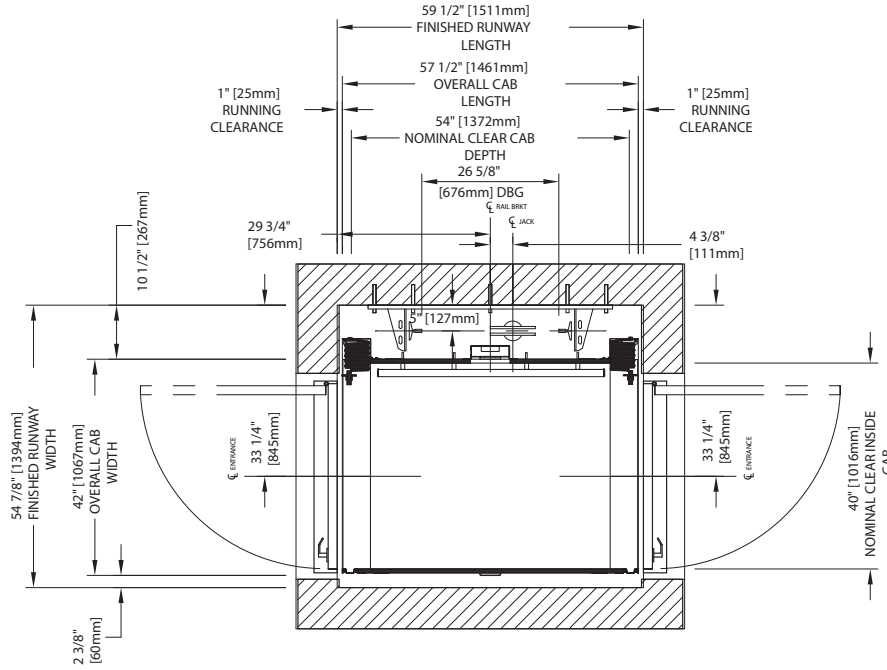

Plan view – Infinity 40" x 54" type 3

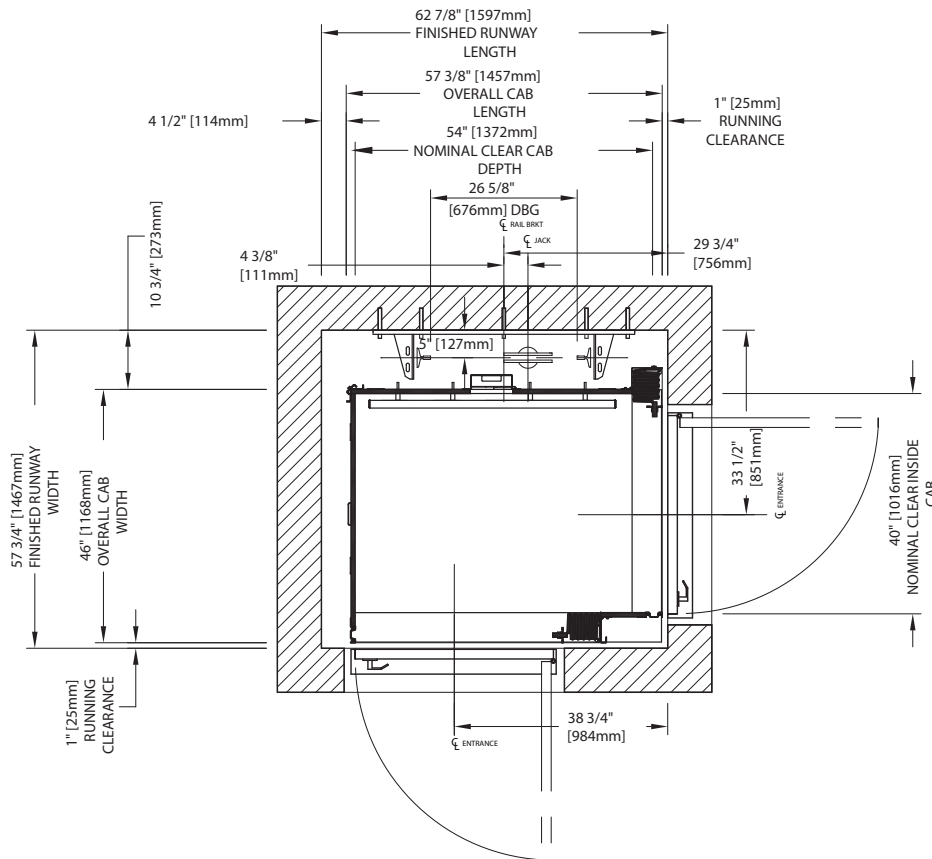

IMPORTANT: Always refer to your plan drawings for dimensions specific to your site.
 For Infinity with **Auto Slim Doors**, DO NOT use the above drawings; refer to **Appendix A** instead.
 For Infinity with **Bi-fold Doors**, DO NOT use the above drawings; refer to **Appendix B** instead.

Plan view – Infinity 40" x 54" type 4

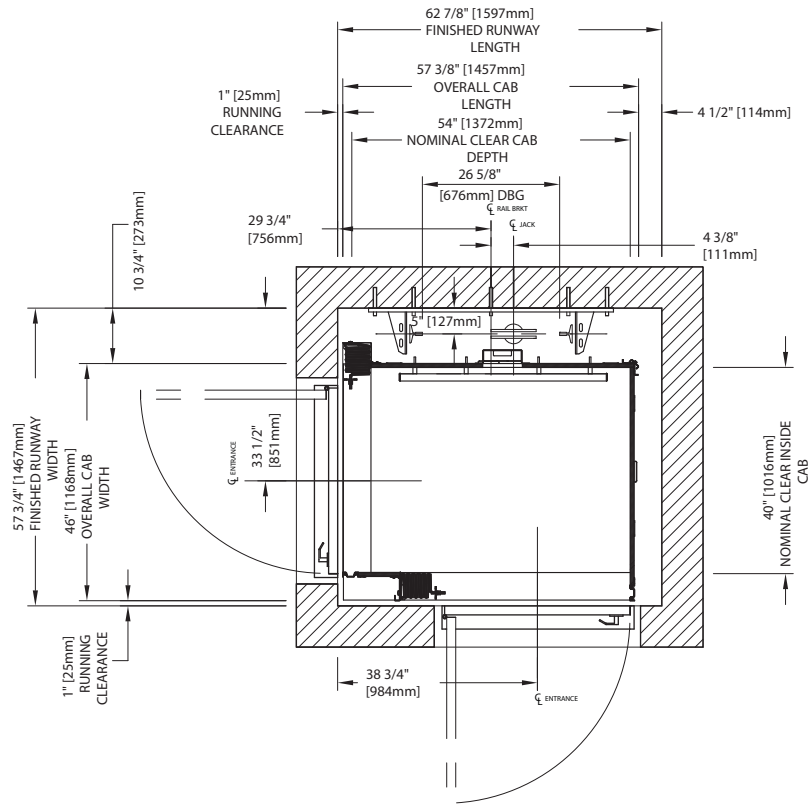

Plan view – Infinity 40" x 54" type 5

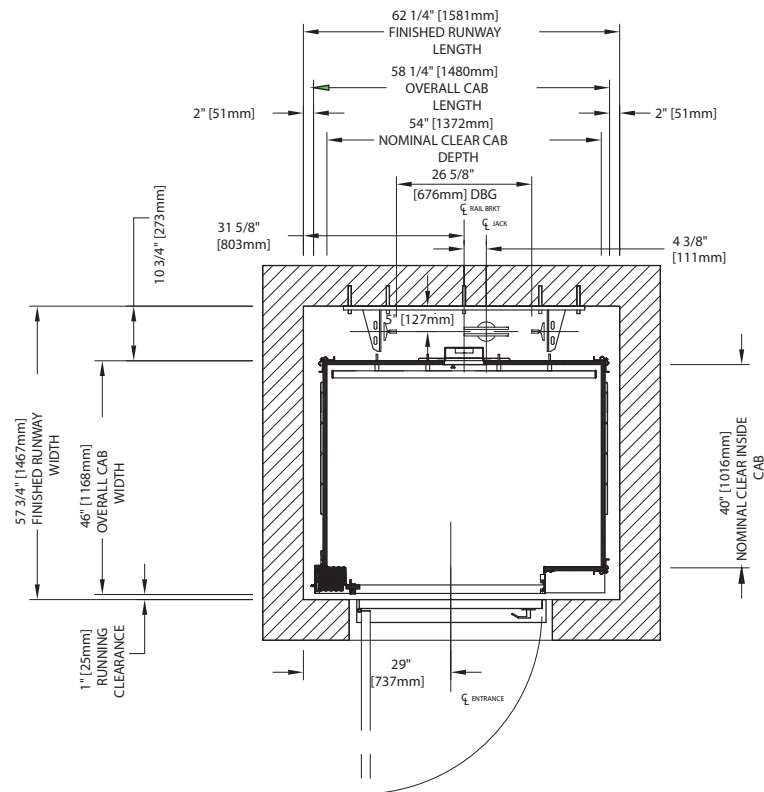

IMPORTANT: Always refer to your plan drawings for dimensions specific to your site.
 For Infinity with **Auto Slim Doors**, DO NOT use the above drawings; refer to **Appendix A** instead.
 For Infinity with **Bi-fold Doors**, DO NOT use the above drawings; refer to **Appendix B** instead.

Elevation view – Infinity HD

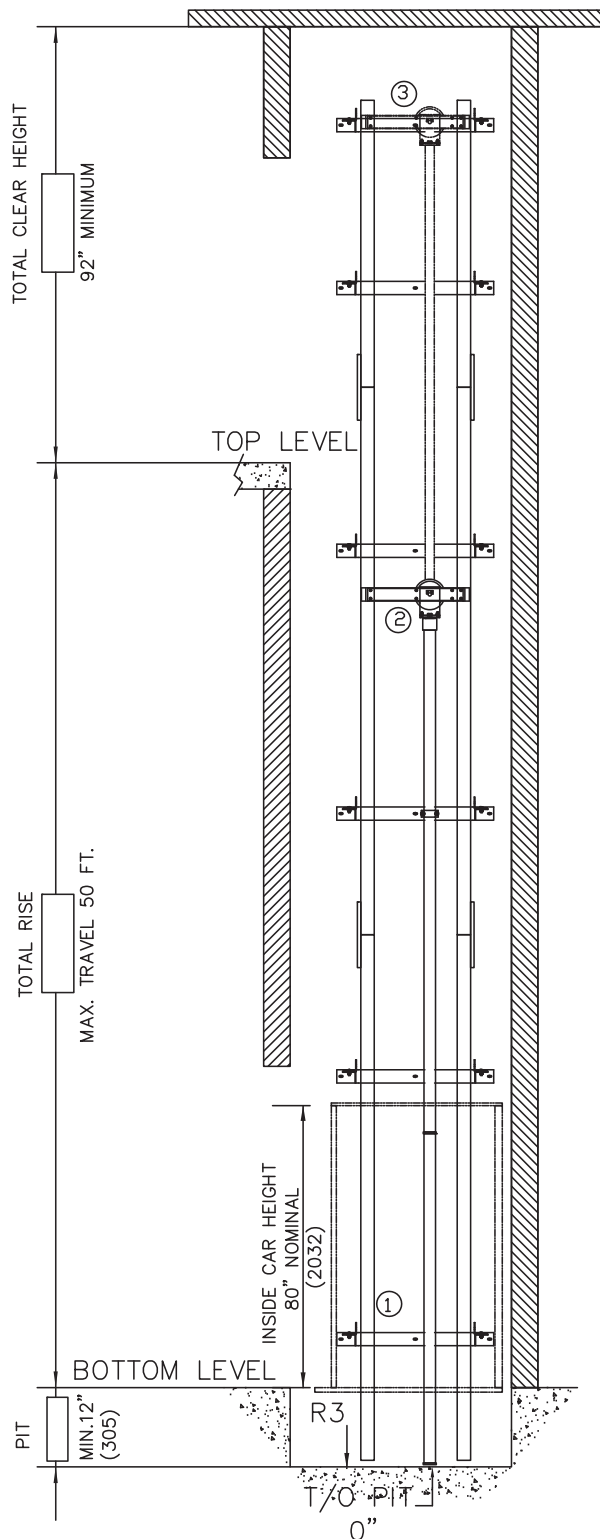

Top rail bracket (3): at top of hoistway (consult your Savaria representative for exact location).
 Intermediate rail bracket (2): 48 in (1219 mm) intervals above bottom bracket.
 Bottom rail bracket (1): 24 in (610 mm) above pit floor.

IMPORTANT: Always refer to your plan drawings for dimensions specific to your site.

For Infinity with **Auto Slim Doors**, DO NOT use the above drawings; refer to **Appendix A** instead.

For Infinity with **Bi-fold Doors**, DO NOT use the above drawings; refer to **Appendix B** instead.

Plan view – Infinity HD 48" x 60" type 1 left-hand

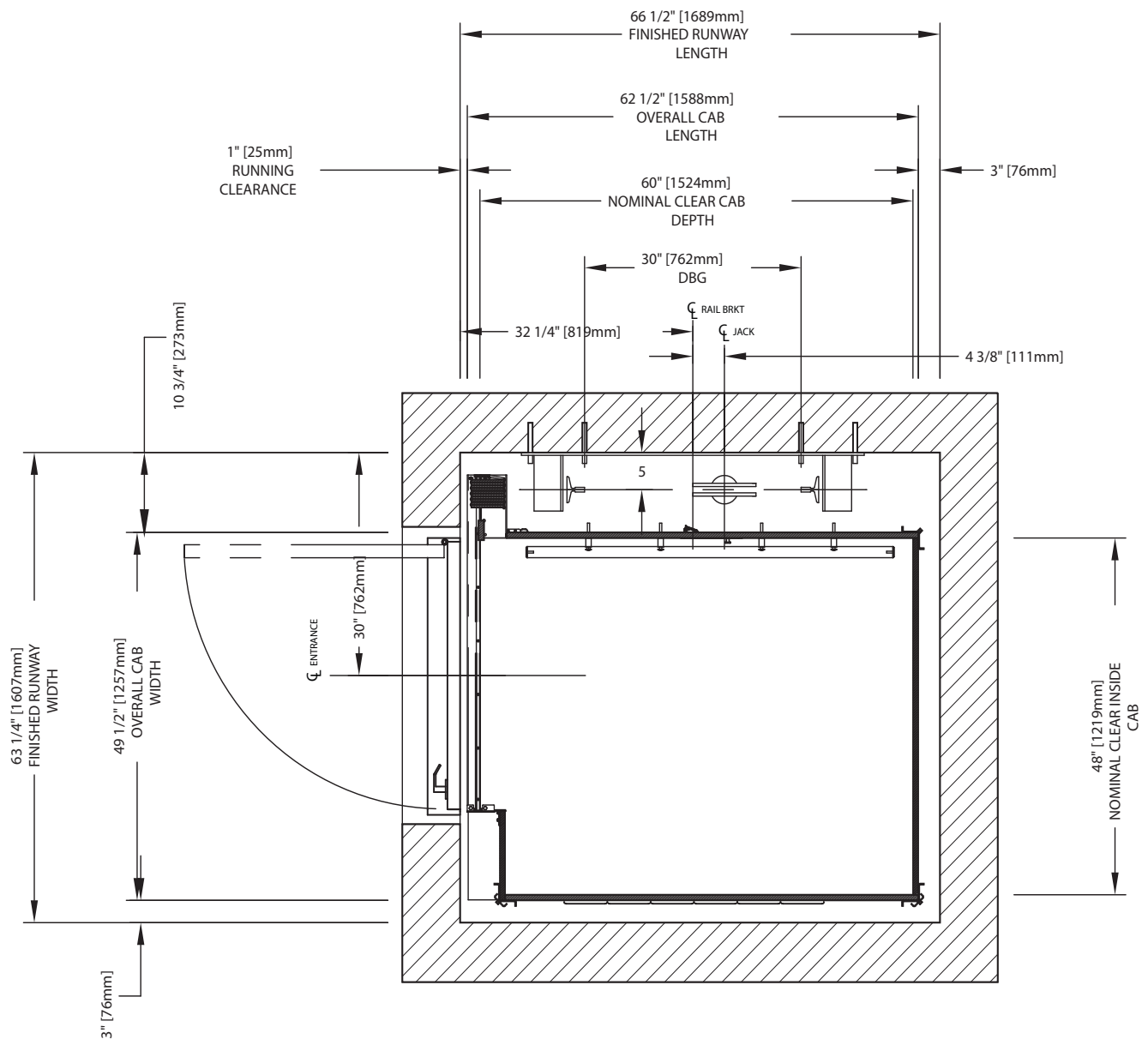

IMPORTANT: Always refer to your plan drawings for dimensions specific to your site.
 For Infinity with **Auto Slim Doors**, DO NOT use the above drawings; refer to **Appendix A** instead.
 For Infinity with **Bi-fold Doors**, DO NOT use the above drawings; refer to **Appendix B** instead.

Plan view – Infinity HD 48" x 60" type 1 right-hand

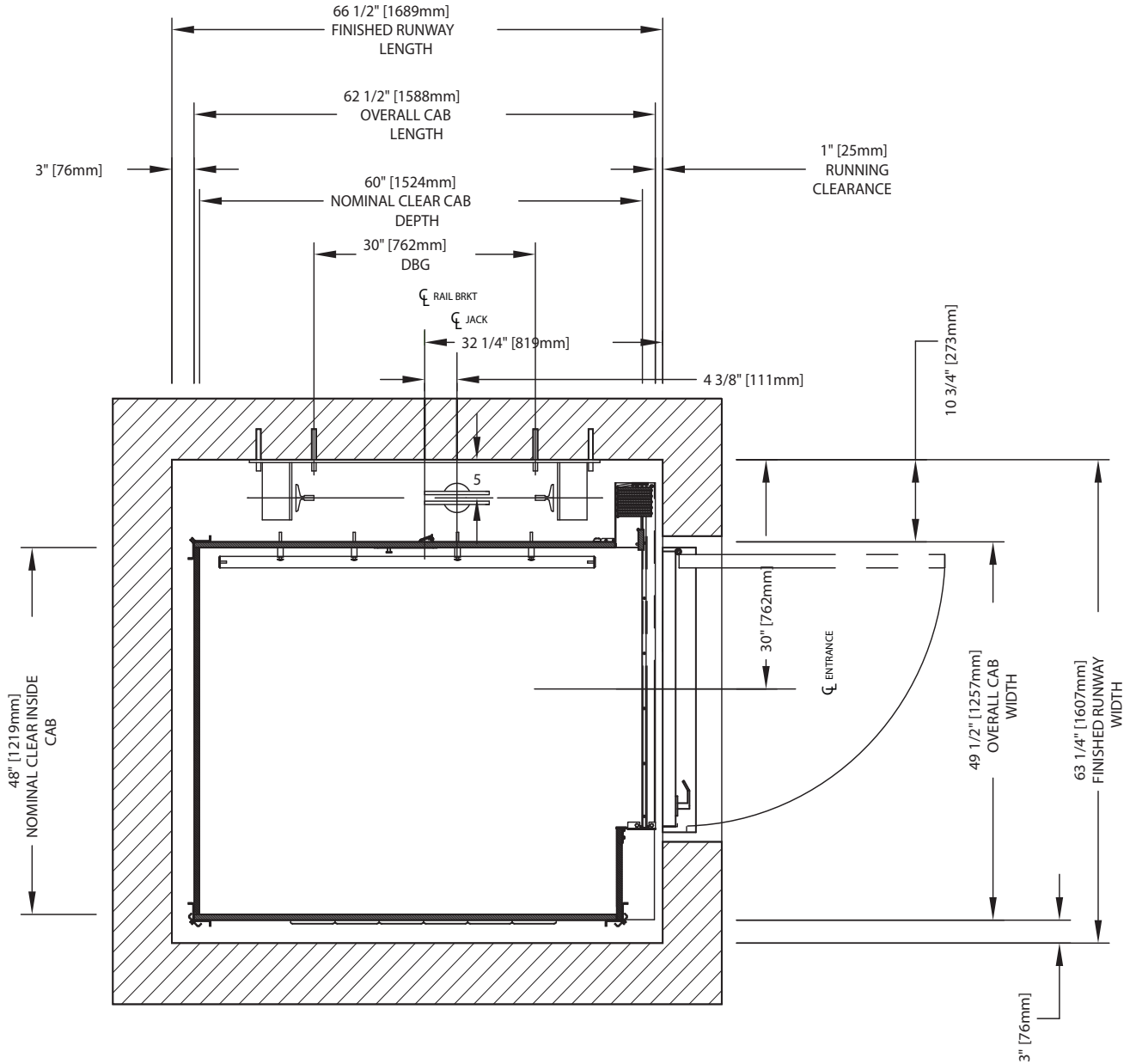

IMPORTANT: Always refer to your plan drawings for dimensions specific to your site.
 For Infinity with **Auto Slim Doors**, DO NOT use the above drawings; refer to **Appendix A** instead.
 For Infinity with **Bi-fold Doors**, DO NOT use the above drawings; refer to **Appendix B** instead.

Plan view – Infinity HD 48" x 60" type 2

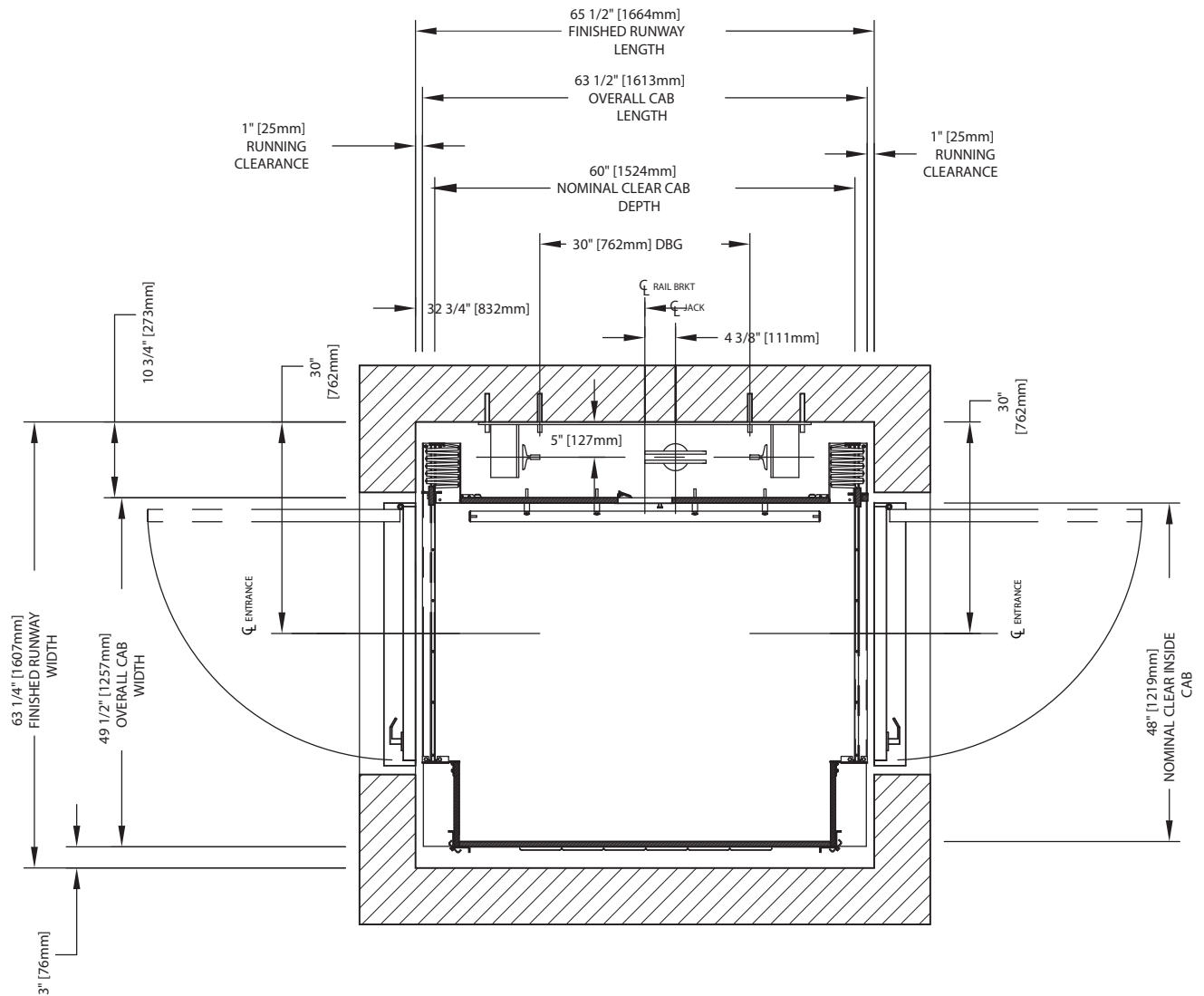

IMPORTANT: Always refer to your plan drawings for dimensions specific to your site.
 For Infinity with **Auto Slim Doors**, DO NOT use the above drawings; refer to **Appendix A** instead.
 For Infinity with **Bi-fold Doors**, DO NOT use the above drawings; refer to **Appendix B** instead.

Plan view – Infinity HD 48" x 60" type 3

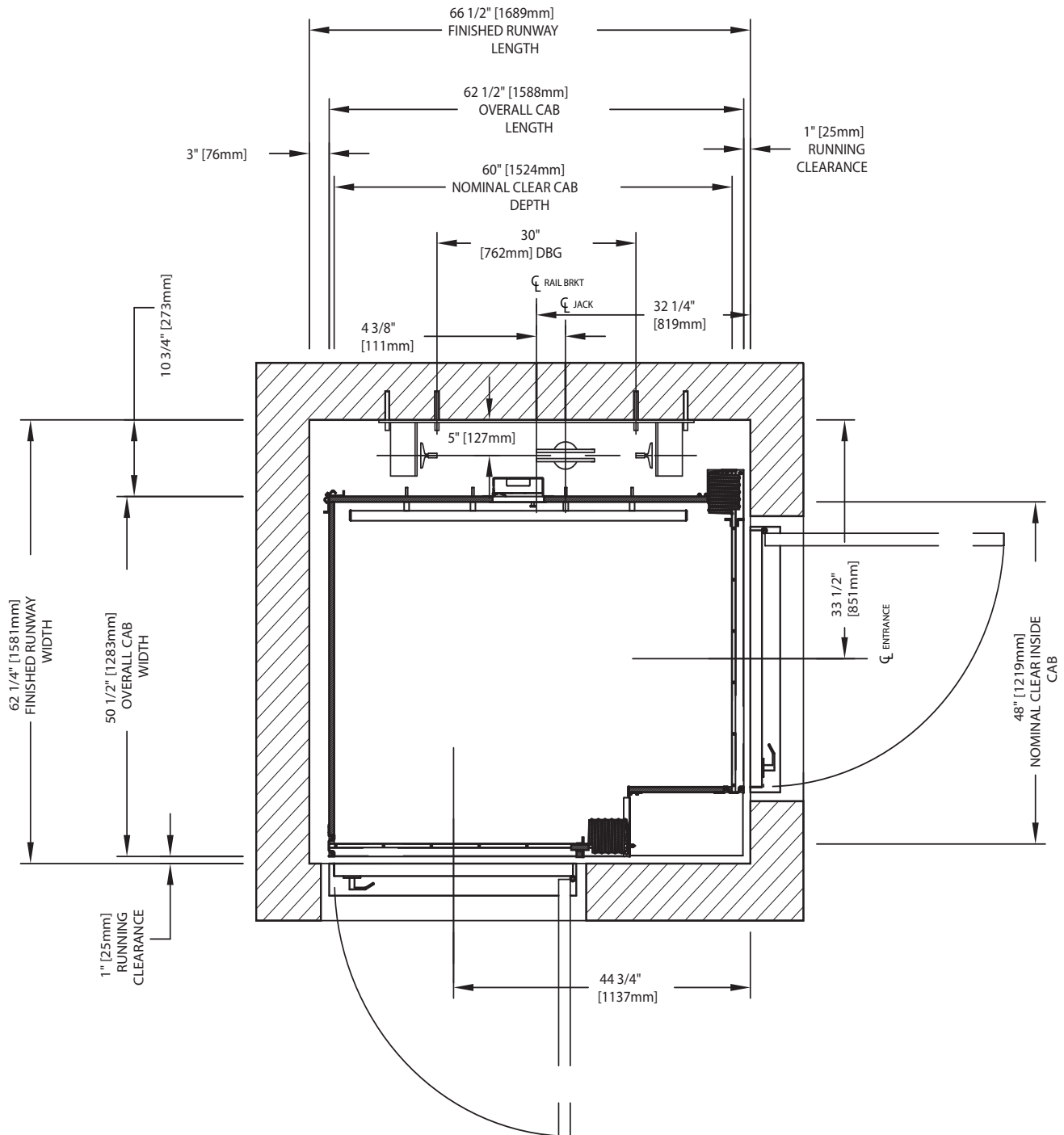

IMPORTANT: Always refer to your plan drawings for dimensions specific to your site.

For Infinity with **Auto Slim Doors**, DO NOT use the above drawings; refer to **Appendix A** instead.

For Infinity with **Bi-fold Doors**, DO NOT use the above drawings; refer to **Appendix B** instead.

Plan view – Infinity HD 48" x 60" type 4

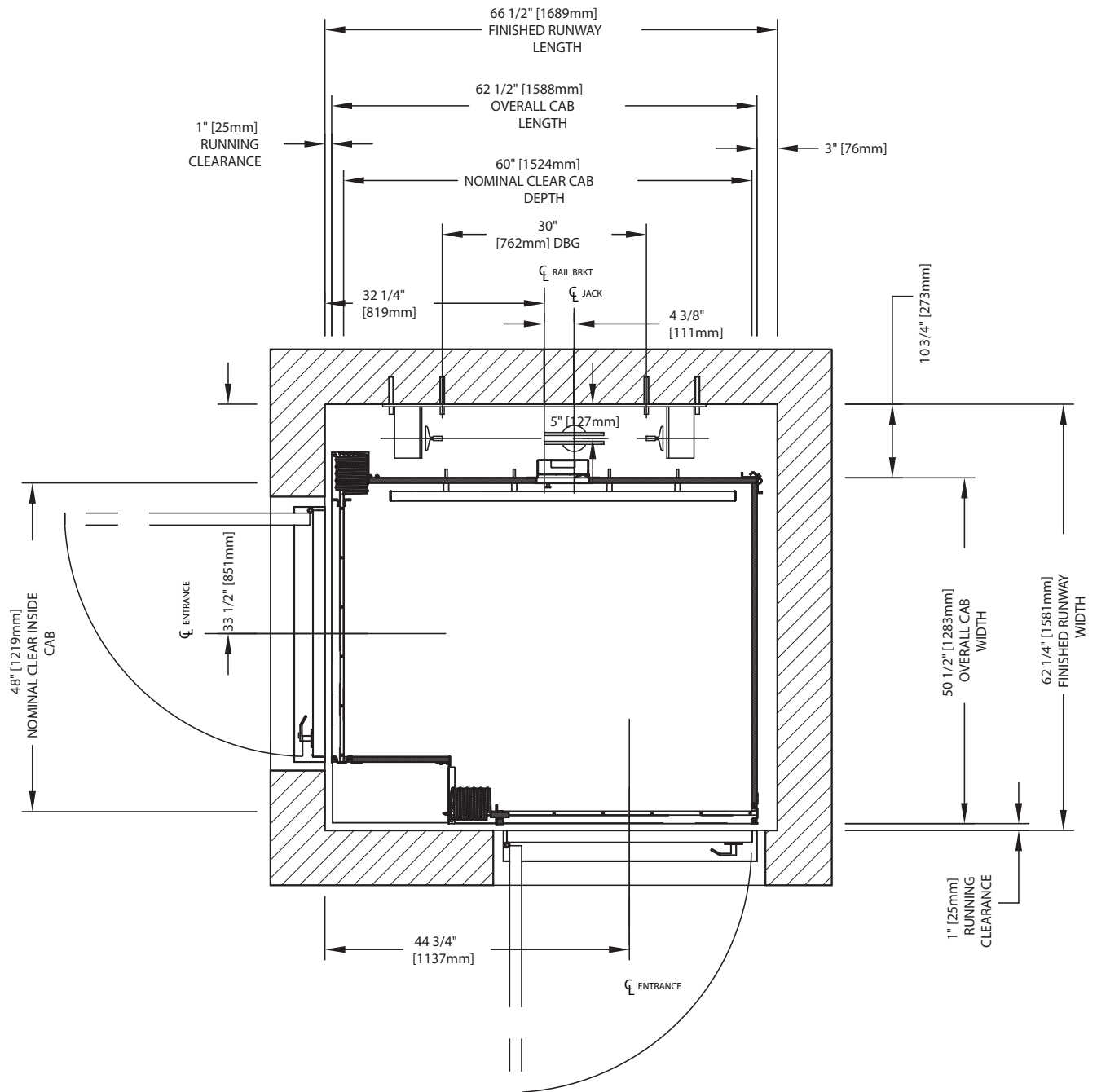

IMPORTANT: Always refer to your plan drawings for dimensions specific to your site.
 For Infinity with **Auto Slim Doors**, DO NOT use the above drawings; refer to **Appendix A** instead.
 For Infinity with **Bi-fold Doors**, DO NOT use the above drawings; refer to **Appendix B** instead.

Plan view – Infinity HD 48" x 60" type 5 (left-hand gate stack/door swing)

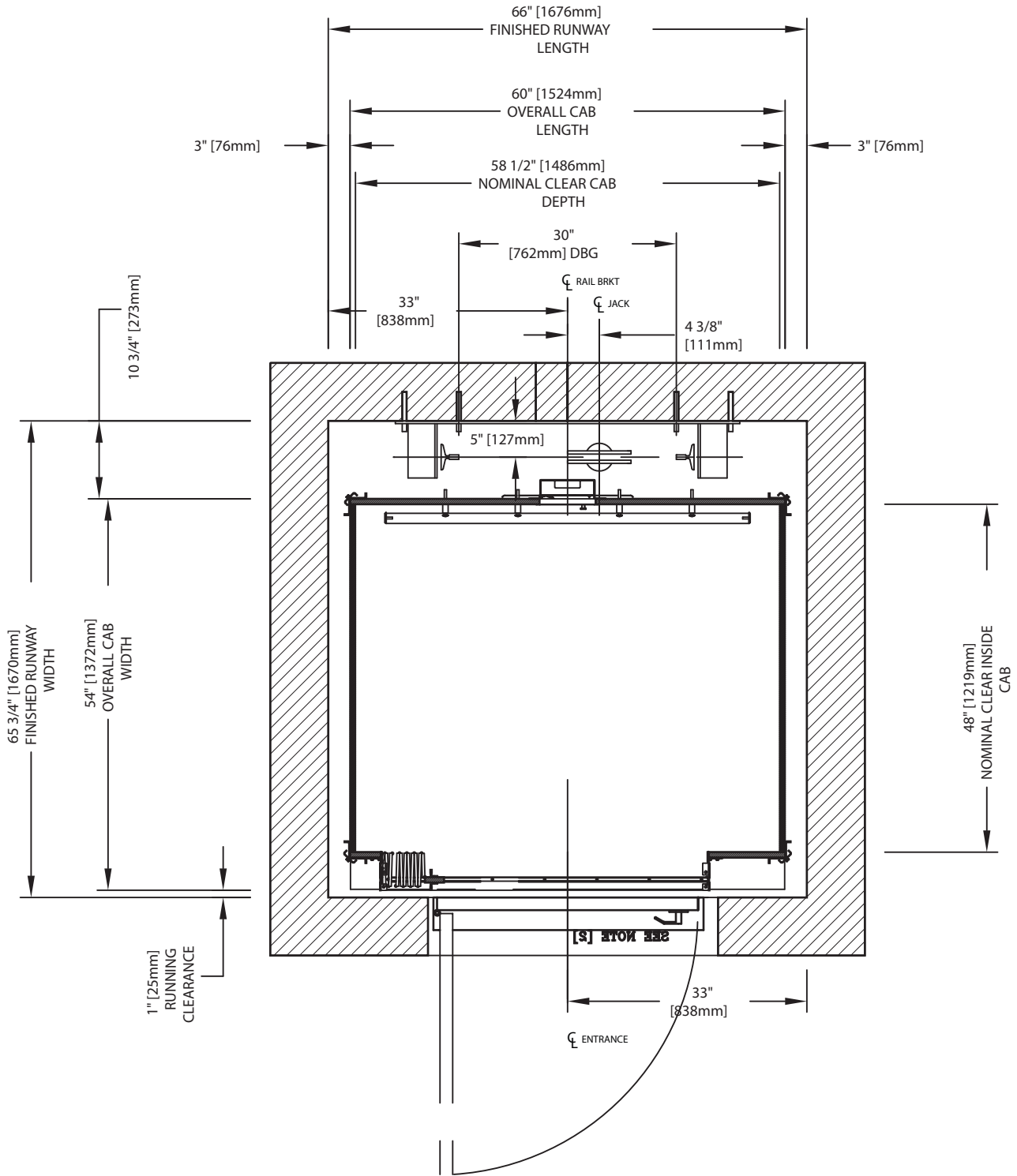

IMPORTANT: Always refer to your plan drawings for dimensions specific to your site.
 For Infinity with **Auto Slim Doors**, DO NOT use the above drawings; refer to **Appendix A** instead.
 For Infinity with **Bi-fold Doors**, DO NOT use the above drawings; refer to **Appendix B** instead.

Plan view – Infinity HD 48" x 60" type 5 (right-hand gate stack/door swing)

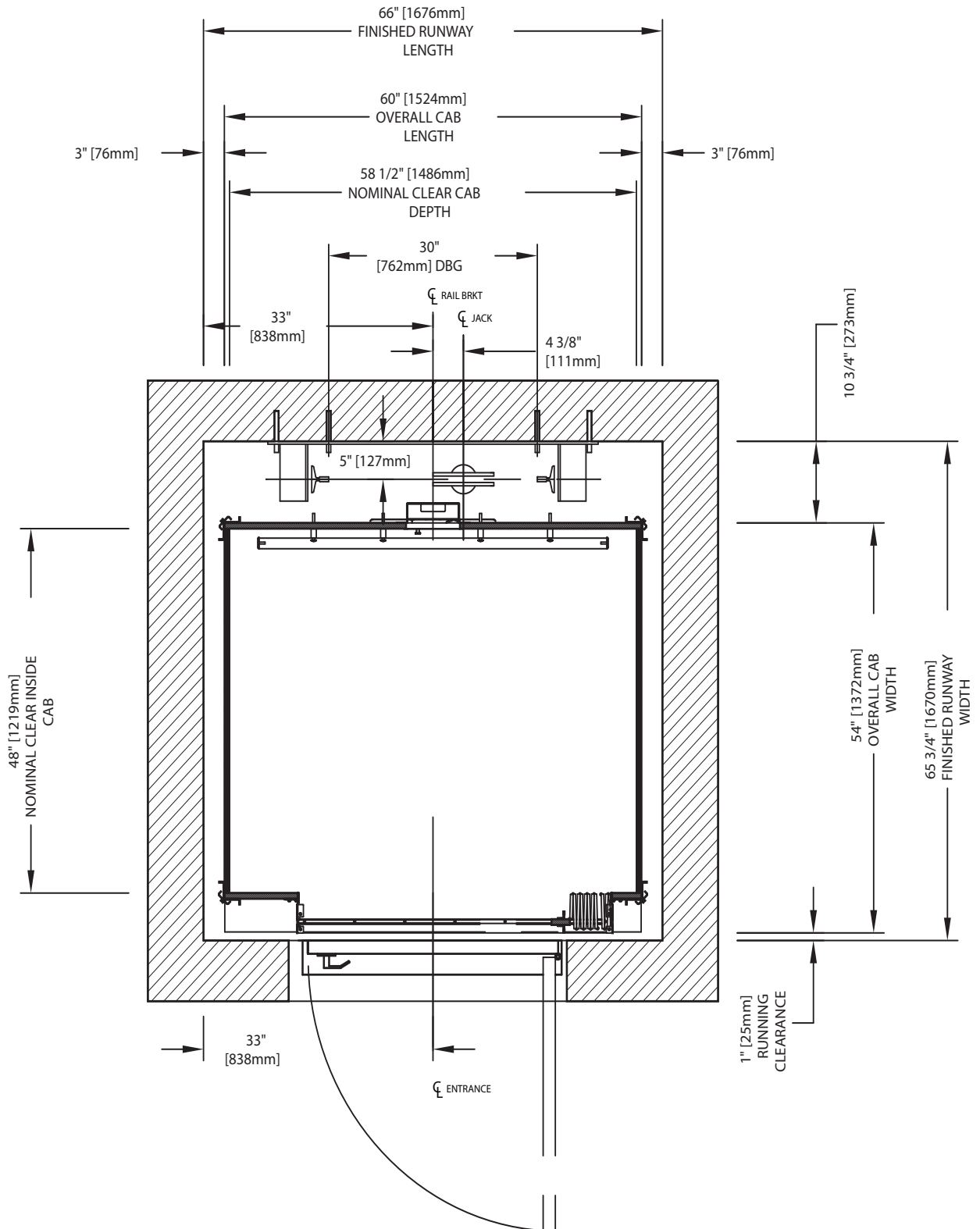

IMPORTANT: Always refer to your plan drawings for dimensions specific to your site.
 For Infinity with **Auto Slim Doors**, DO NOT use the above drawings; refer to **Appendix A** instead.
 For Infinity with **Bi-fold Doors**, DO NOT use the above drawings; refer to **Appendix B** instead.

Door and gate specifications

For door and gate specifications, go to our website www.savaria.com, select the “architects and builders” tab at the top of the page and then select “Doors and Gates” from the menu on the left-hand side of the page.

The link is as follows: <http://www.savaria.com/architects/drawings/doors-gates/index.php>.

Recommendation: We recommend installation of a solid door as a hollow door may be too flexible and cause potential lock issues.

Loads on building and rail dimensions

RAIL FORCES		
		
* R1	* R2	CAPACITY
422 lbf.	251 lbf.	1400 lbs.
304 lbf.	194 lbf.	1000 lbs.
RAIL WEIGHT : 8.0 lbs / ft		

R3 NOTE:	
PIT FLOOR TO SUPPORT LOAD OF: * (INCLUDES IMPACT)	
CAPACITY	
8.22 Kips	1400 lbs.
5.6 Kips	1000 lbs.

FOR TOTAL PULL-OUT FORCE ON RAIL BRACKET, R1 MUST BE DOUBLED eg. 608 lbf for 1000 lbs.

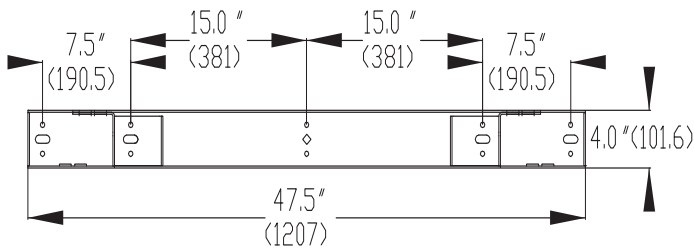
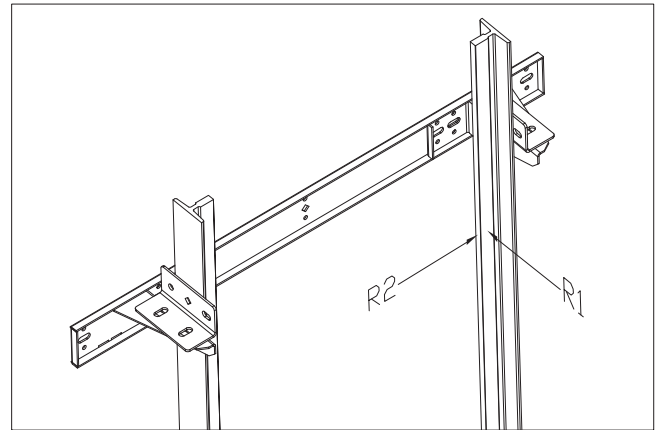
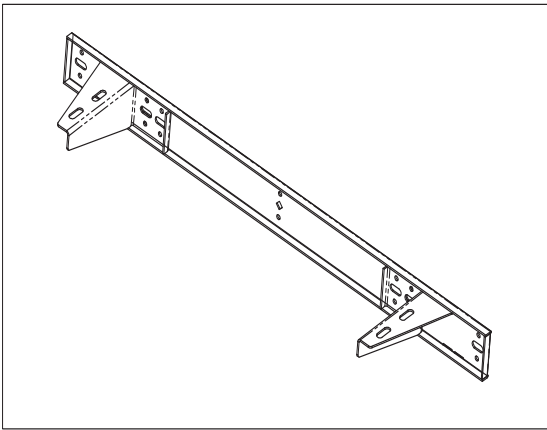

Rail bracket dimensions (Infinity)

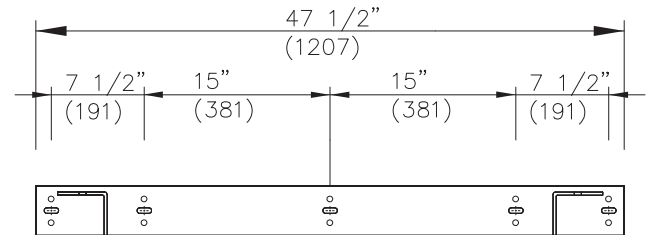

Rail bracket dimensions (Infinity HD)

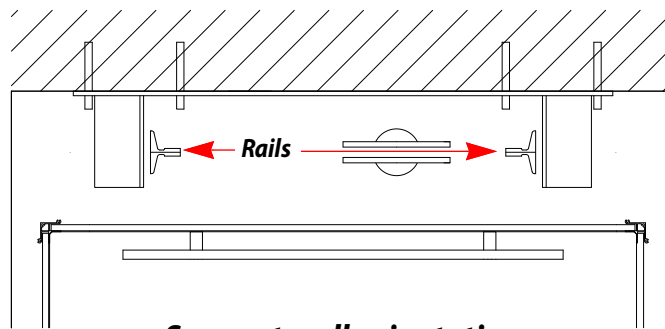

Support wall orientation

Pit details

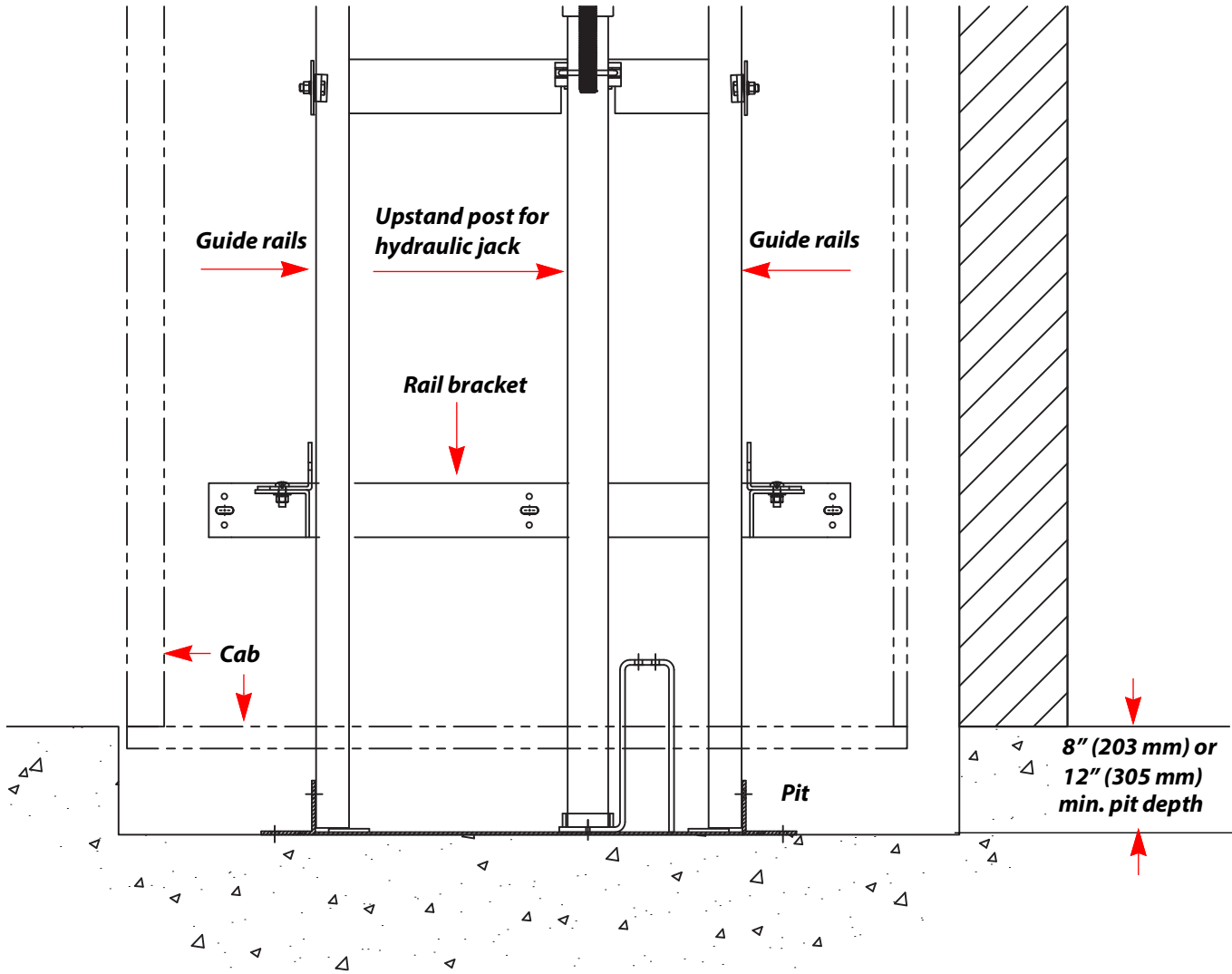

Hoistway and pit notes

- A load bearing wall is required to sustain rail reactions (refer to the section "Loads on building" on the previous page).
- Suggested hoistway pit floor construction consists of an 8" (203 mm) concrete slab poured on a natural or compacted soil with a minimum allowable bearing pressure of 1.0 KSF.
- The minimum compressive strength of the concrete at 28 days must be no less than 3000 PSI. #5 reinforcing steel (grade 60) must be placed at the bottom of the slab in two traverse directions and at a spacing of 12" (305 mm).
- Hoistway pit floor to support a load (including impact) of 5.6 kips (5600 lb/24.9 kN) for Infinity or 8.22 kips (8220 lb/36.6 kN) for Infinity HD.
- Minimum overhead clearance of 92" (2337 mm) for 80" (2032 mm) cab, 96" (2438 mm) for 84" cab, 108" (2743 mm) for 96" cab, and 100" (2540 mm) for units with auto slim doors.
- Minimum pit depth of 8" (203 mm) for Infinity and 12" (305 mm) for Infinity HD.
- Hoistway sizes reflect running and access clearances only. Consult your local AHJ to assure compliance with local codes.
- Hoistway is required to be free of all pipes, wiring and obstructions not related to the operation of the elevator.

Masonry construction – sectional view

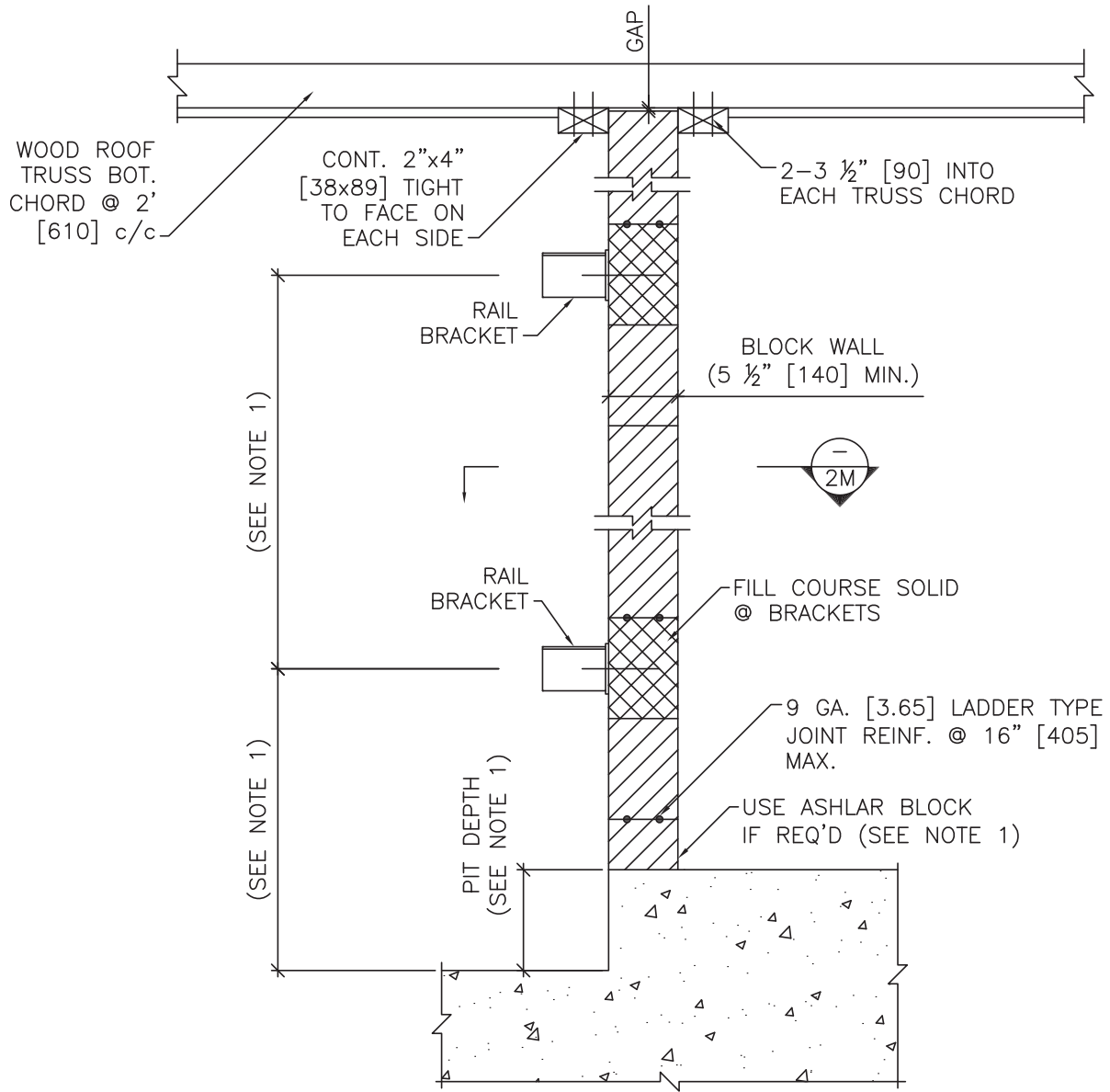

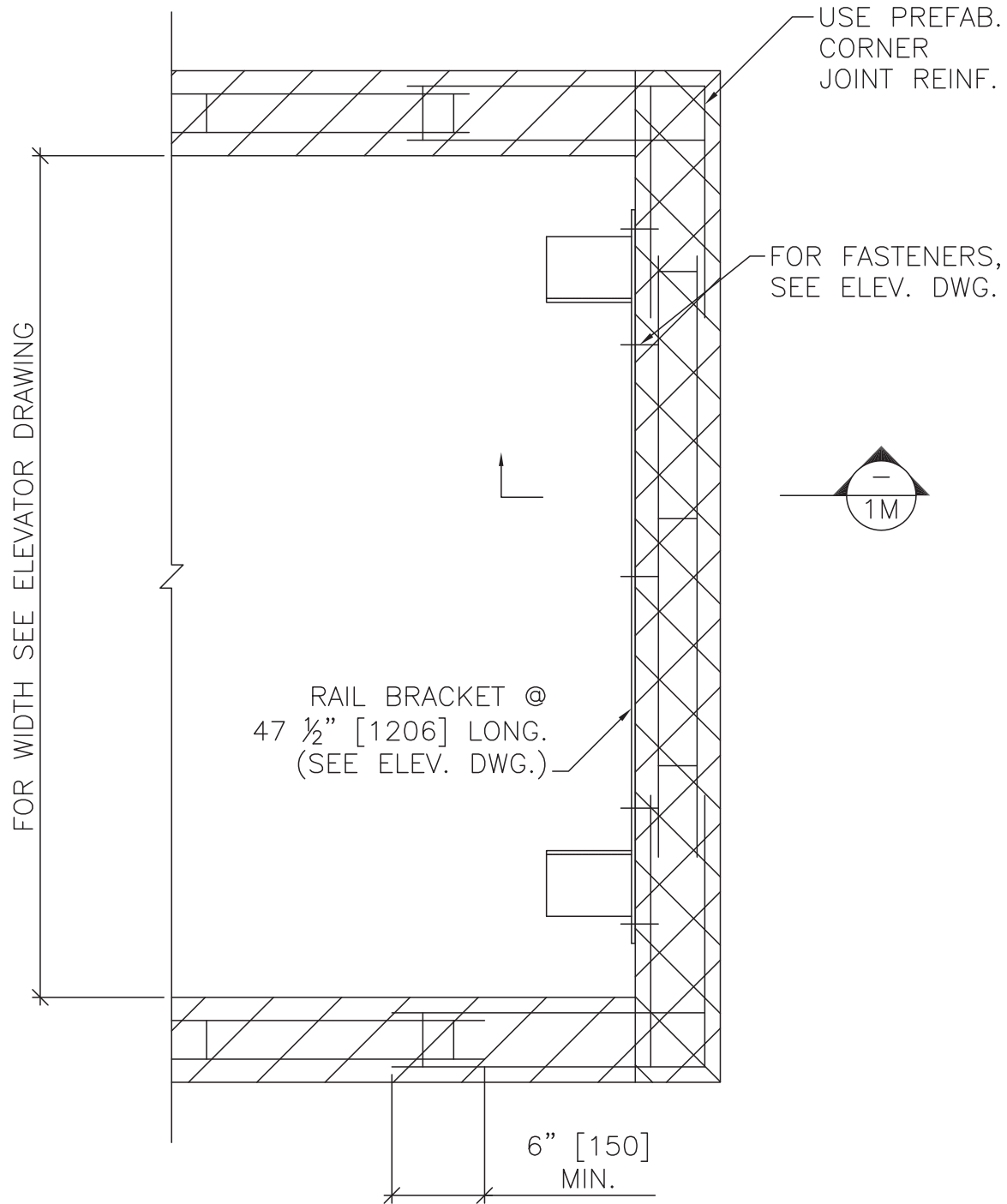
Masonry construction – plan view

Wood construction – sectional view

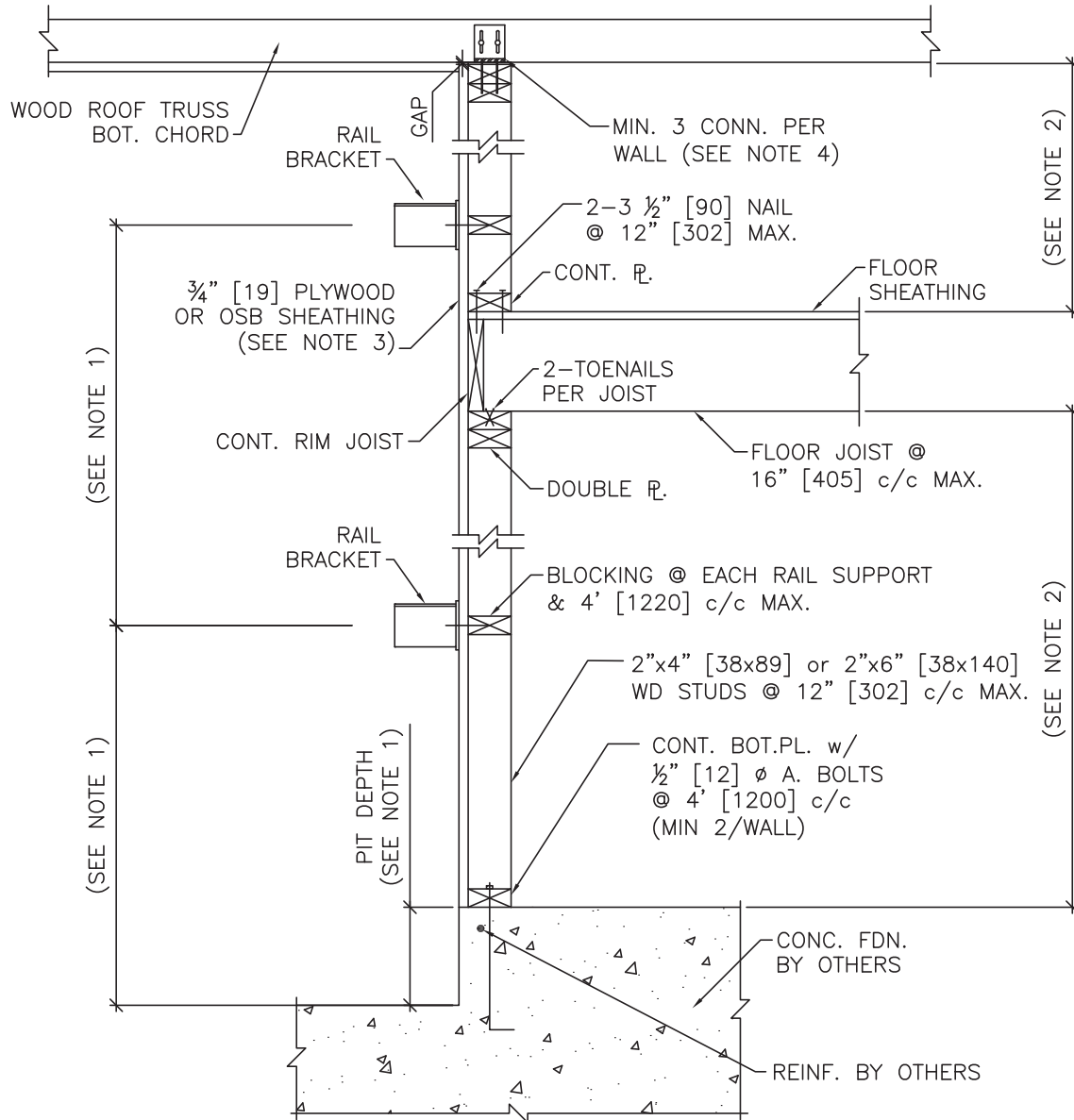

For Reference Only

Wood Stud Partitions (Load-Bearing) – 2-Hour Rating

<p>152 mm 6"</p> <p>wt. 59 kg/m² (12 PSF)</p>	<p>Wd Stud—2 layers 15.9 mm (5/8") SHEETROCK brand gypsum panels, FIRECODE core, or SHEETROCK brand gypsum panels, water-resistant, FIRECODE core, or SHEETROCK Vinyl-Faced Gypsum Panels, FIRECODE Core, ea side—2x4 400 mm (16") o.c.—base layer att with 48 mm (1 3/4") nails 150 mm (6") o.c.—face layer att with 60 mm (2 3/8") nails 200 mm (8") o.c.—joints fin—ULC Des U301, UL Des U301</p>	<p>N/A</p>	<p>SA924 SA928</p> <p>101</p>
<p>152 mm 6"</p> <p>wt. 59 kg/m² (12 PSF)</p>	<p>Wd Stud—2 layers 15.9 mm (5/8") SHEETROCK brand gypsum panels, FIRECODE C core, ea side—2x4 400 mm (16") o.c.—76 mm (3") THERMAFIBER SAFB—RC-1 chan or equiv one side, spaced 600 mm (24") o.c.—resil side screw att—opp side nail att—both base layers appl vert and face layers appl horiz—resil layers perim caulked—joints fin—UL Des U334</p>	<p>59</p> <p>TL-67-239</p>	<p>SA924</p> <p>102</p>
<p>152 mm 6"</p> <p>wt. 63 kg/m² (13 PSF)</p>	<p>Wd Stud—2 layers 15.9 mm (5/8") SHEETROCK brand gypsum panels, FIRECODE C core, ea side—2x4 400 mm (16") o.c.—51 mm (2") THERMAFIBER SAFB—RC-1 chan or equiv one side, spaced 600 mm (24") o.c.—resil side screw att—opp side nail att—both base layers appl vert and face layers appl horiz—resil layers perim caulked—joints fin—UL Des U334</p>	<p>58 52</p> <p>USG-810219 Based on same assembly (non-fire rated) without SAFB—USG-810218</p>	<p>SA924</p> <p>103</p>

Wood construction – plan view

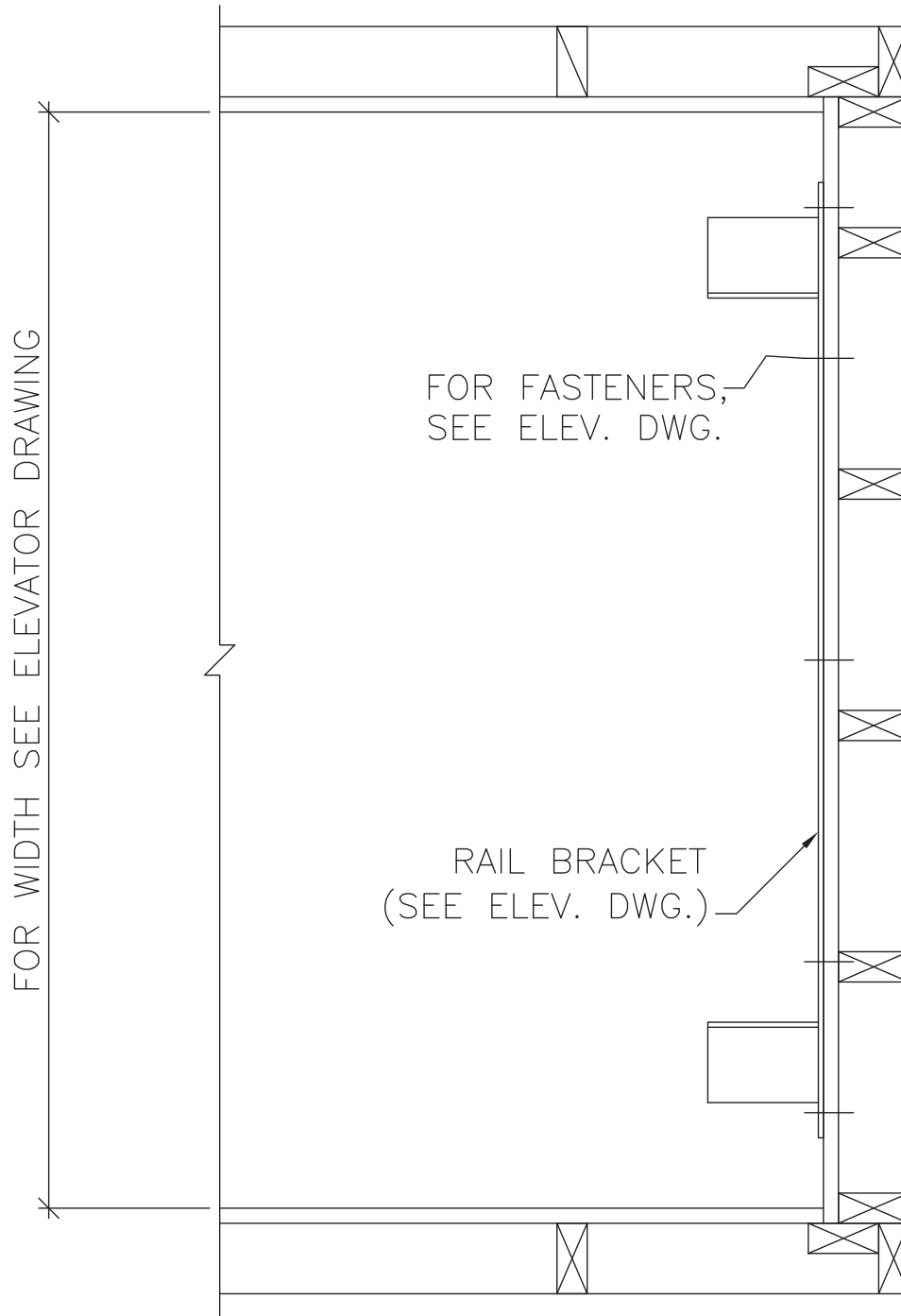

Suggested wall configuration for wood construction (sheet 1)

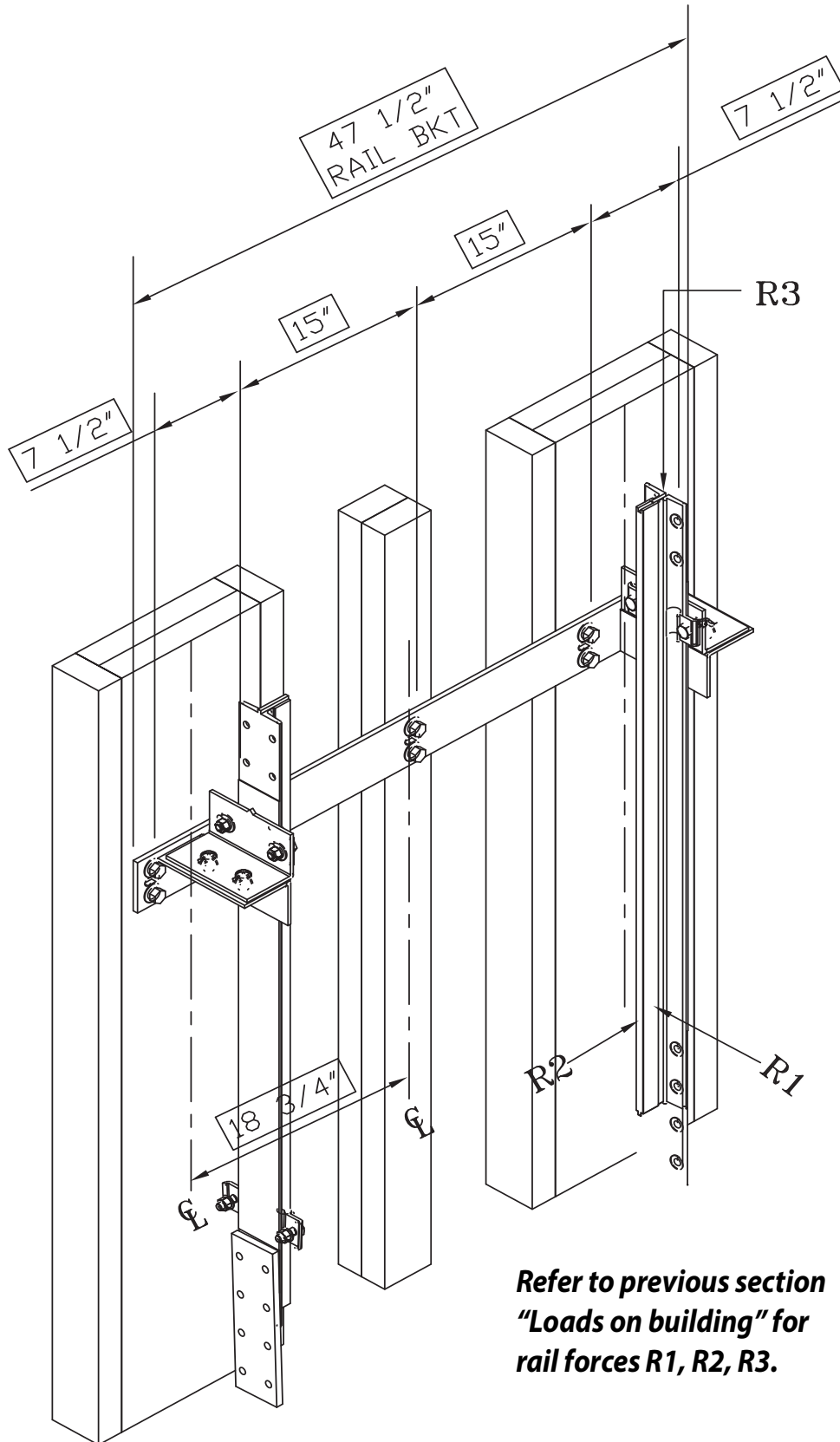

Suggested wall configuration for wood construction (sheet 2)

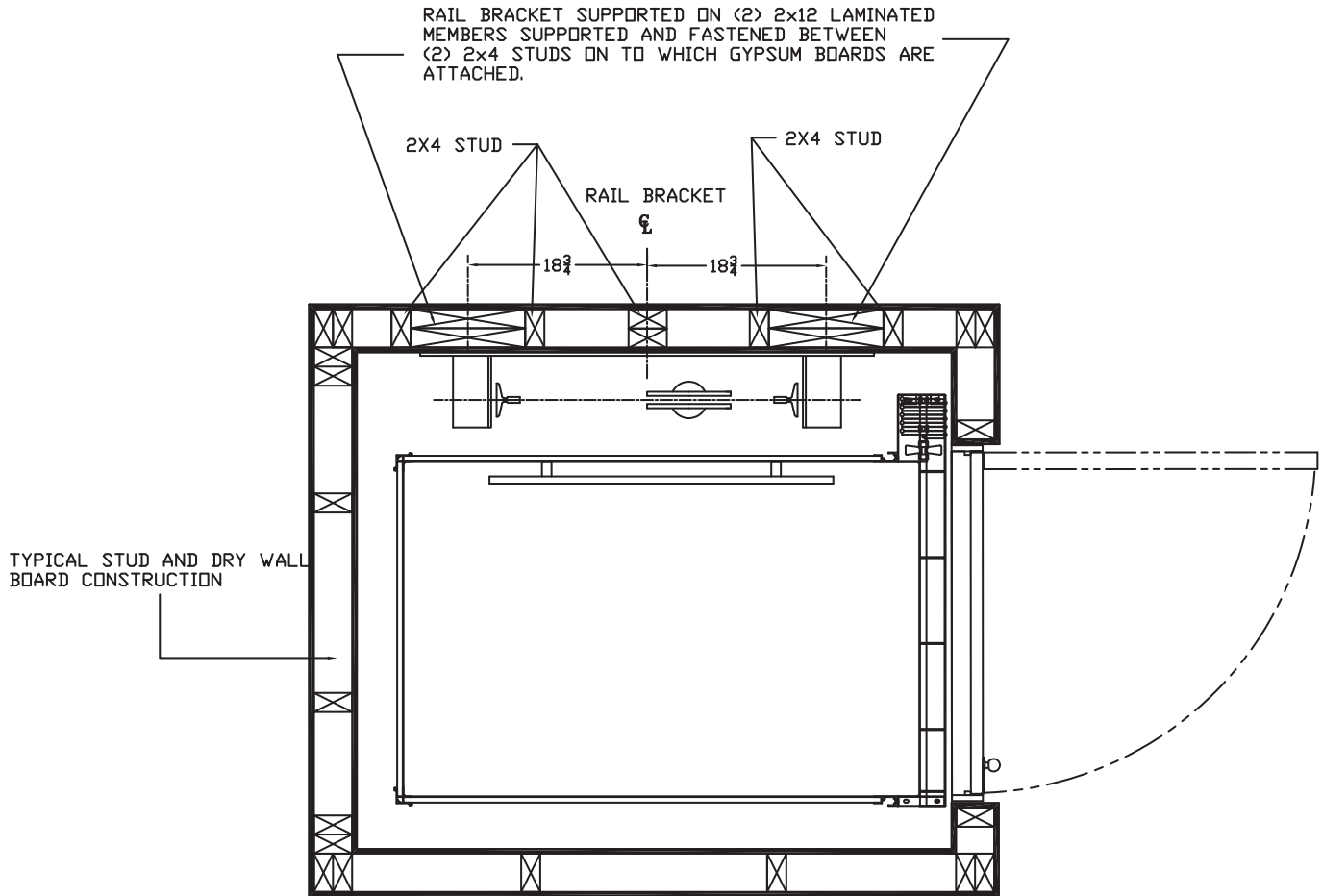

NOTE:

1. THIS DRAWING IS FOR REFERENCE ONLY. BUILDING STRUCTURAL ENGINEER TO ENSURE THAT THE BUILDING AND HOISTWAY WILL SAFELY SUPPORT ALL LOADS IMPOSED BY THE LIFT EQUIPMENT
2. FIRE RATING OF HOISTWAY IS SUBJECT TO LOCAL BUILDING CODES.

Rail support wall specifications

Drawing notes

- 1) See the lift installation (shop) drawings for rail bracket spacing and pit depth.
- 2) Wall lateral support spacing:
 - For 2" x 4" studs, use 6 ft 10" (2090 mm) max.
 - For 2" x 6" studs, use 13 ft 6" (4120 mm) max.
- 3) Sheathing installation: install sheets vertically full width of shaft or min. centred on rail brackets.
- 4) Connectors to resist horizontal load but allow vertical movement. For wood, use 2" x 1/4" cap screw lag bolts.

General specifications

- G1 The design and construction of all work is to conform to the local applicable building code.
- G2 Read the installation (shop) drawings in conjunction with all related architectural, mechanical, electrical, and lift drawings as well as any other contract documents.
- G3 The wall drawings have been prepared using engineering principles and the design loads that are applied by the lift rails to the wall. However, the details and member sizes and the attachments to the structure should not be construed as a complete design of the wall system. The contractor and/or the project engineer is responsible to evaluate the other loads that are applied to the wall from the floor or roof system and modify member sizes or connections as required by their analysis.
- G4 Do not scale the drawings.
- G5 See the lift installation (shop) drawings for service loads (including dynamic effects) which are:
 - Horizontal load parallel to the wall: 194 lbf (0.86 kN) for Infinity; 251 lbf (1.12 kN) for Infinity HD
 - Horizontal load perpendicular to the wall: 304 lbf (1.35 kN) for Infinity; 422 lbf (1.88 kN) for Infinity HD
- G6 Wood: SPF NO 1/2 Mix
 Concrete: 3000 psi (20 Mpa) @ 28 days. If exposed use 5% to 7% air content.
 Anchor bolts: ASTM A307
 Mortar: Type "S"
 Masonry grout: 2100 psi (14 Mpa) high slump
 Masonry block: 2100 psi (14 Mpa) on net area
- G7 Wall to be installed plumb and square within 1/8" (3 mm) of top and bottom of shaft.
- G8 Wall lateral support spacing (H) selected for maximum horizontal deflection of H/360 from rail loads.

Wood construction

- W1 Separate wood from concrete with waterproof barrier or use pressure treated wood.
- W2 Bridging maximum spacing: Load bearing or shear walls – 4 ft (1219 mm) c/c.
- W3 Nail or screw sheathing at 6" (152 mm) c/c at edges and 12" c/c to other members.
 Use 2.5" standard Ardox nails or 2" #12 screws.

Masonry construction

- M1 All masonry construction to conform to applicable local standards
- M2 Reinforce lintel blocks with 2 m-15 m bottom bars unless noted.
- M3 Provide continuous ladder type joint reinforcement at 16" (400 mm) c/c.

Provisions by others

Hoistway

- The hoistway must be designed and built in accordance with all applicable codes (identified on the cover of this manual) and all state and local codes.
- Due to close running clearances, owner/agent must ensure that hoistway and pit (where provided) are level, plumb and square and are in accordance with the dimensions on the installation (shop) drawings.

Minimum overhead clearance

- Owner/agent must ensure minimum overhead clearance is in compliance with codes.

Construction site

- Owner/agent to provide all masonry, carpentry and drywall work as required and shall patch and make good (including finish painting) all areas where walls/floors may need to be cut, drilled or altered in any way to permit the proper installation of the lift.

Dimensions

- Contractor/customer to verify all dimensions and report any discrepancies to our office immediately.

Structural

- Structural engineer to assure that building and shaft will safely support all loads imposed by the lift equipment. Refer to the tables on installation (shop) drawings for loads imposed by the equipment.
- Suitable lintels must be provided by owner/agent. Door frames are not designed to support overload wall loads.

Entrances

- Entrance assemblies must be adjusted to align with platform and interlock equipment. Others to allow an adequate rough opening.
- Return walls at entrances must be built-in by others after entrance assemblies are in place. Entrance assembly must be securely fastened to walls by elevator contractor.
- Fascia panel below upper level entrance where required. Fascia panel must be fastened to a solid wall and be perpendicular to the floor and walls. Hoistway fascia is not self-supporting for long, continuous runs void of entrances. Adequate support for the fascia must be provided.

Machine room

- Machine room must be located at the lowest level adjacent to hoistway, unless shown otherwise on installation (shop) drawings. Field adjustment by installer may be necessary to meet job site conditions or regulations. Access to machine room to be through self-closing lockable door.
- Sleeves for oil and electric lines must be provided from machine room to runway as required (positioned per installer's instructions).

Electrical

- Power supply with a lockable fused disconnect and auxiliary contact to break the battery feed, or circuit breakers with a 3-pole breaker for battery feed required, in compliance with electrical code, located on the wall on the lock jamb side of the machine room door. Contact your Savaria dealer or refer to one of the tables on the next page for OEM part numbers.
- Permanent power of 208 volts, three-phase, 30 amps or 230 volts, single-phase, 40 amps must be supplied by others before installation begins.
- Owner/agent to ensure at least 9.3 foot-candles (100 lux) ambient lighting over lift area.
- Remote hall call (when supplied) to be installed by the owner/agent at 42" (1067 mm) from landing floor and 8" (203 mm) from the door edge.

For Infinity and Infinity HD (5 HP pump unit)

Disconnect Switch Types & Accessories	Cutler Hammer	Federal Pioneer	Siemens
1 Phase 5 H.P. Pump Unit			
2 Pole 240V 1 PH	1HD222N	1322SN	ID321
Required Auxiliary Contact	DS16CP	E1K-1AEV-W94	MSSAK 116
Required Type "D" Fuse (Buss type "FRN" or equal)	2@40 amp	2@40 amp	2@40 amp
3 Phase 5 H.P. Pump Unit			
3 Pole 208V 3 PH	1HD321N	1332SN	ID321
Required Auxiliary Contact	DS16CP	E1K-1AEV-W94	MSSAK 116
Required Type "D" Fuse (Buss type "FRN" or equal)	3@30 amp	3@30 amp	3@30 amp
Cab Lighting			
1 Pole Solid Neutral 120V 1 PH	GP 111N	86211	CFN 211
Required Type "D" Fuse (Buss type "T" or equal)	1@15 amp	1@15 amp	1@15 amp

Savaria Link Option

- If you have the Savaria Link Ethernet remote monitoring option, ensure that you have an Ethernet connection with Internet capability in the vicinity of the unit's controller.
- If you have the Savaria Link Wireless remote monitoring option, ensure that you have a wireless signal with Internet capability in the vicinity of the unit's controller.

Flush wood door instructions for contractors

METHOD TO BUILD FLUSH DOOR: USING STOPPER ON INSIDE OF DOOR FRAME



HOISTWAY VIEW WITH 1/8" SHEET-METAL STOPPER

WARNING : Lock cut-out in top corner representative of a standard 80" door. For taller doors, such as 84" to 96", the top of the cut-out itself needs to stay at 80" from the ground to allow users access to unlock in case of emergency.

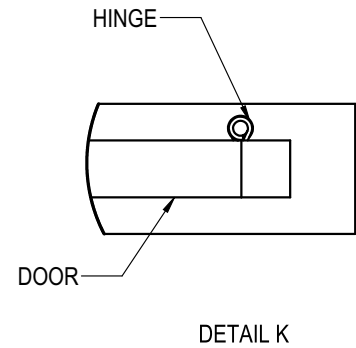
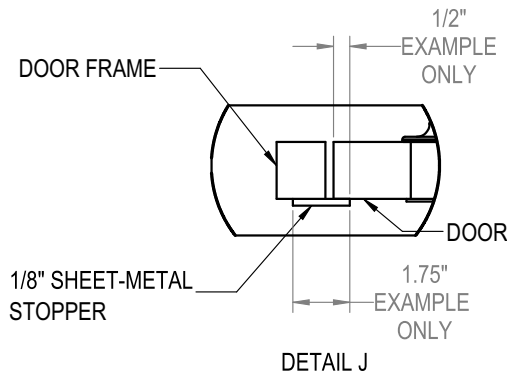
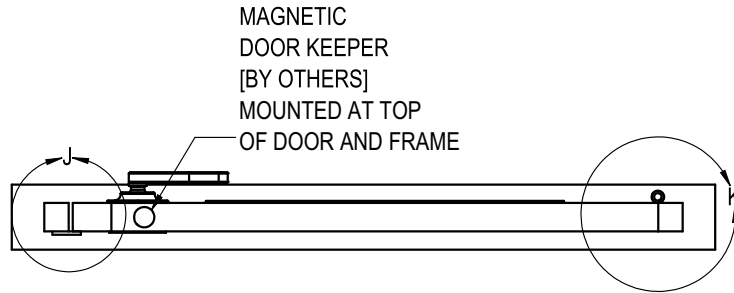

3X HINGES (SPRING HINGES OR DOOR CLOSER ON HYDRAULIC ELEVATOR AND VPL UNITS)

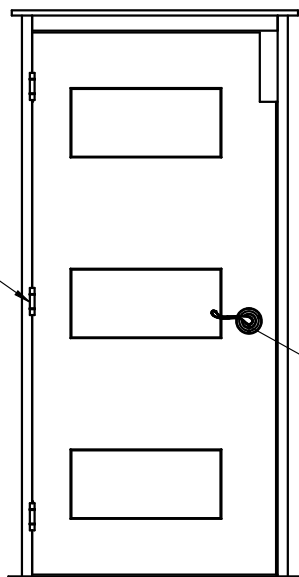

LANDING VIEW

XXX CLEAR DOOR WIDTH

SHEET-METAL STOPPER FLUSH TO DOOR LOCK CUT-OUT

CUP STYLE DOOR HANDLE [BY OTHERS] FROM HOISTWAY VIEW MUST BE FLUSH / RECESSED
NON-FUNCTIONAL DOOR HANDLE [BY OTHERS] FROM LANDING VIEW

2-3/8" DOOR LOCK CUT-OUT ON DOOR

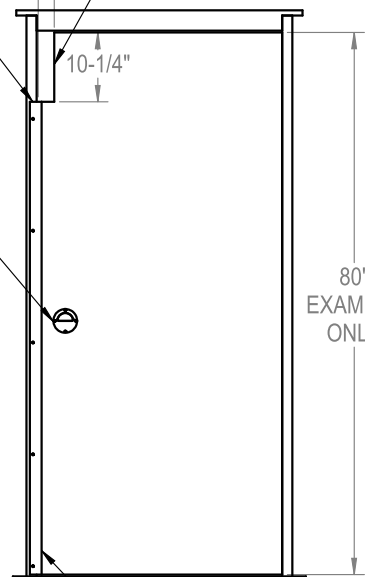

HOISTWAY VIEW

Flush wood door instructions for contractors (cont.)

METHOD TO BUILD FLUSH DOOR USING ANGLE (L) BRACKET STOPPER

WARNING: Lock cut-out in top corner representative of a standard 80" door. For taller doors, such as 84" to 96", the top of the cut-out itself needs to stay at 80" from the ground to allow users access to unlock in case of emergency.



HOUSE VIEW WITH "L" BRACKET STOPPER

MAGNETIC DOOR KEEPER [BY OTHERS] MOUNTED AT TOP OF DOOR AND FRAME

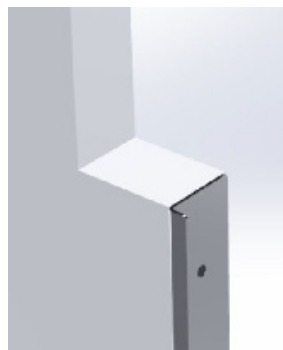
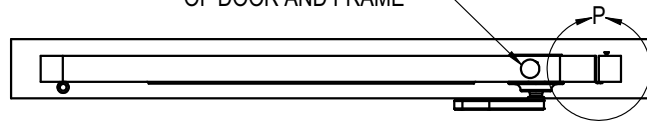

DETAIL M "L" BRACKET MOUNTED ON DOOR SLAB

"L" BRACKET [BY OTHERS]

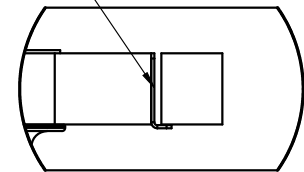

DETAIL P SCALE 1 : 4

CUP STYLE DOOR HANDLE [BY OTHERS] FROM HOISTWAY VIEW MUST BE FLUSH / RECESSED

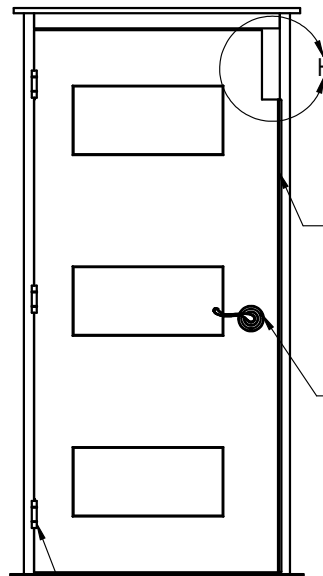
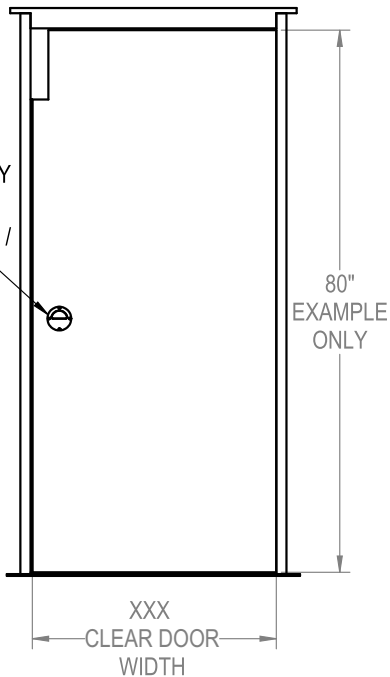

"L" BRACKET [BY OTHERS]
NON-FUNCTIONAL DOOR HANDLE [BY OTHERS] FROM LANDING VIEW

3X HINGES (SPRING HINGES OR DOOR CLOSER ON HYDRAULIC ELEVATOR AND VPL UNITS)

DETAIL H

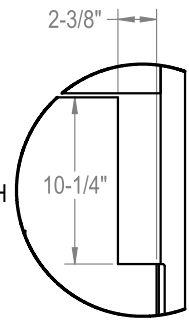

"L" BRACKET FLUSH AT TOP AND BOTTOM

Flush wood door instructions for contractors (cont.)

FLUSH DOOR MADE USING DOOR SPACER

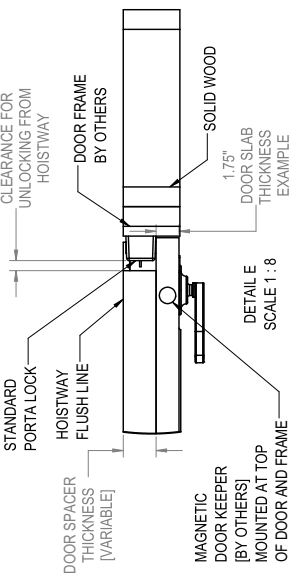

EXAMPLE SHOWN - PLEASE REFER TO FIELD MEASUREMENTS

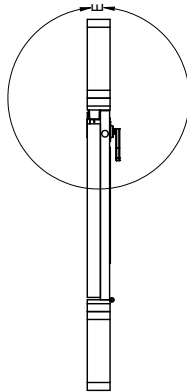

WARNING: Lock cut-out in top corner representative of a standard 30" door. For taller doors, such as 84" to 96", the top of the cut-out itself needs to stay at 80" from the ground to allow users access to unlock in case of emergency.



LANDING VIEW

HOISTWAY VIEW WITH SPACER

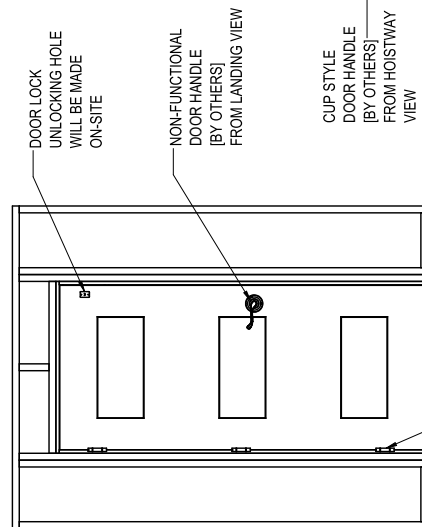
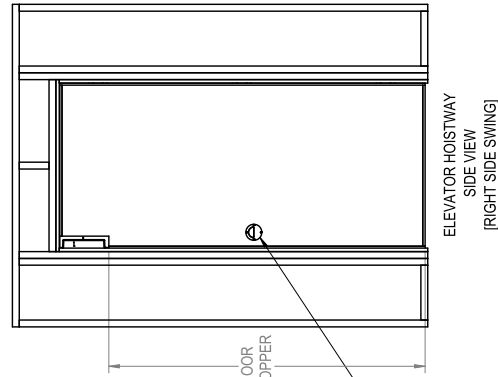
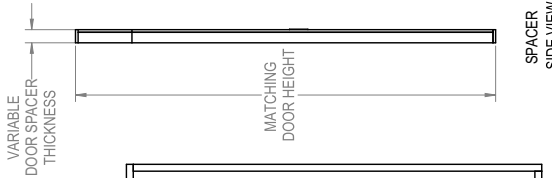
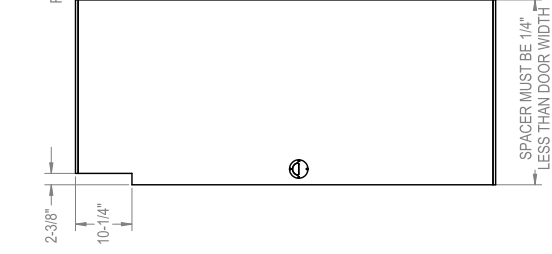
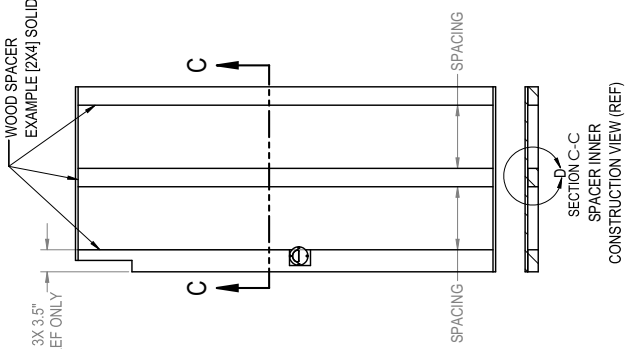
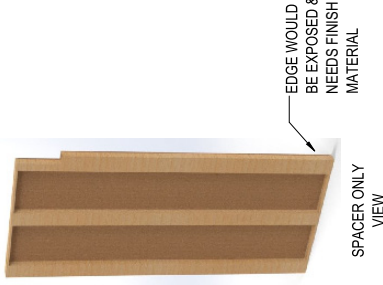
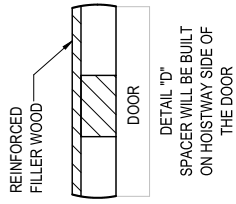

Flush wood door instructions for contractors (cont.)

**LOCK CUTOUT DIMENSIONS: FLUSH PORTA
LOCK BRACKET**

WARNING: Lock cut-out in top corner representative of a standard 80" door. For taller doors, such as 84" to 96", the top of the cut-out itself needs to stay at 80" from the ground to allow users access to unlock in case of emergency.

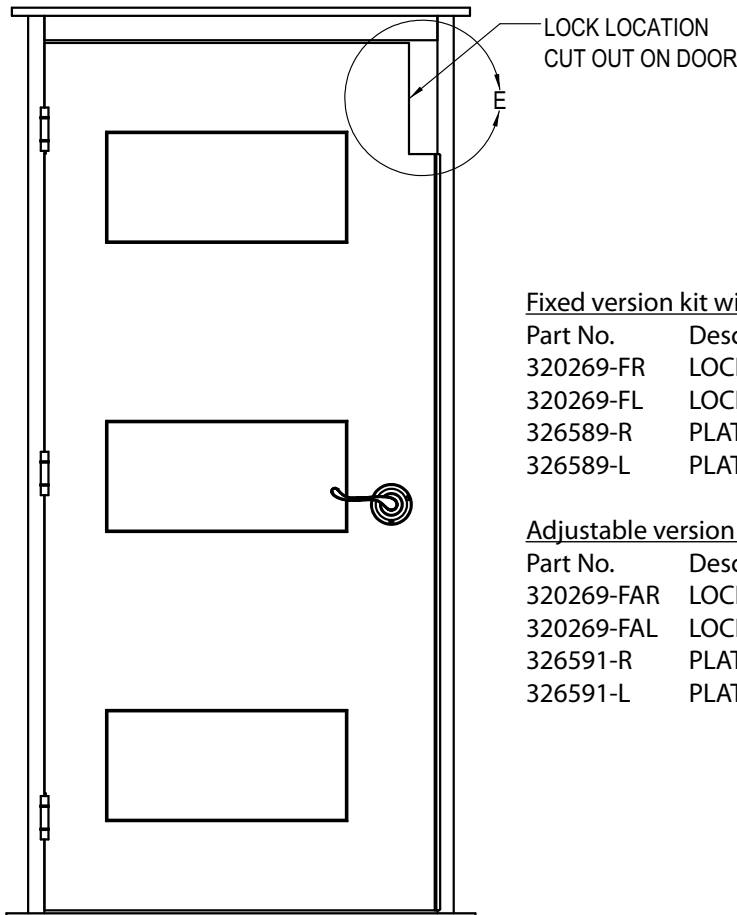

Fixed version kit with lock

Part No.	Description
320269-FR	LOCK_PORTA WOOD DR FLSH, RH ASSY
320269-FL	LOCK_PORTA WOOD DR FLSH, LH ASSY
326589-R	PLATE ONLY, RH
326589-L	PLATE ONLY, LH

Adjustable version kit with lock

Part No.	Description
320269-FAR	LOCK_PORTA WOOD DR FLSH, RH ASSY
320269-FAL	LOCK_PORTA WOOD DR FLSH, LH ASSY
326591-R	PLATE ASSEMBLY ONLY, RH
326591-L	PLATE ASSEMBLY ONLY, LH

LOCK BRACKET OPTIONS:

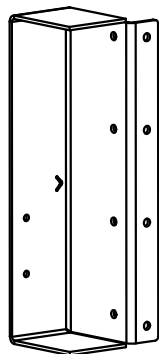

OPTION-1
FOR 1-3/4" DOOR
THICKNESS

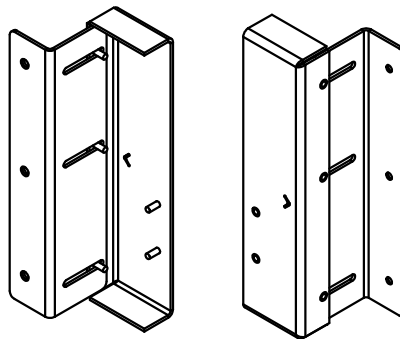

OPTION-2
2 PIECES LOCK
BRACKET FOR 1-1/2" - 2"
DOOR THICKNESS

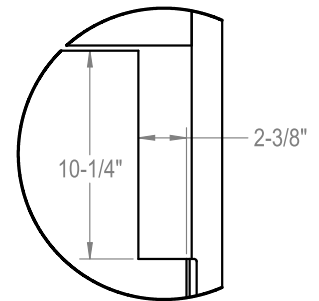

DETAIL E
SCALE 1 : 8

COP dimensions

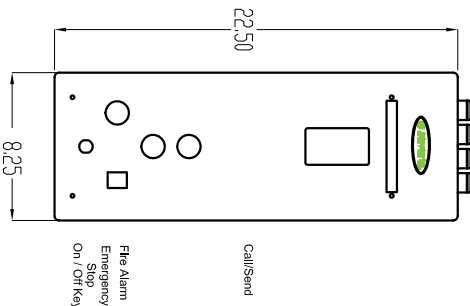
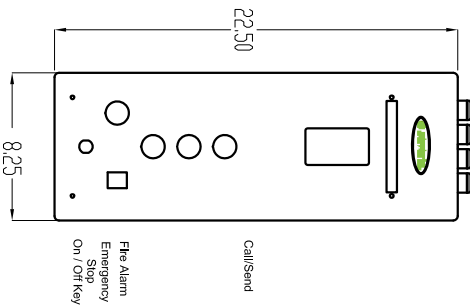
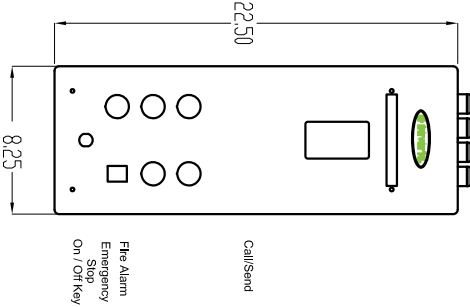
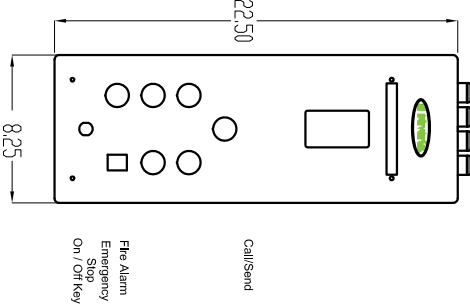
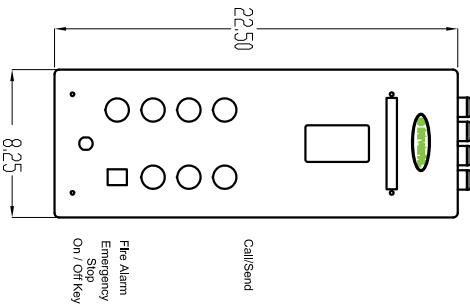
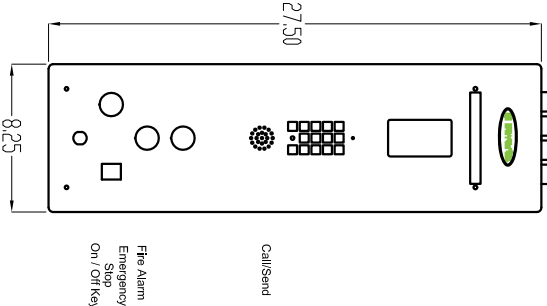
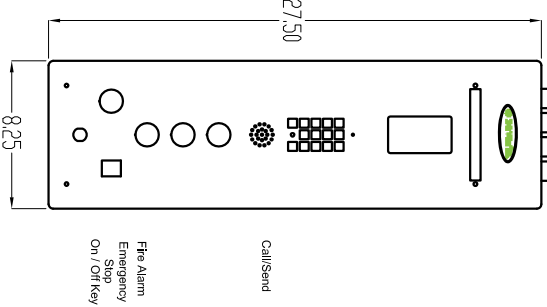
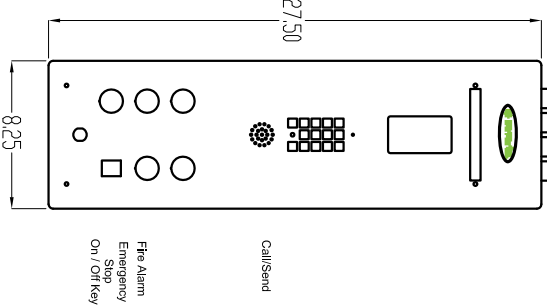
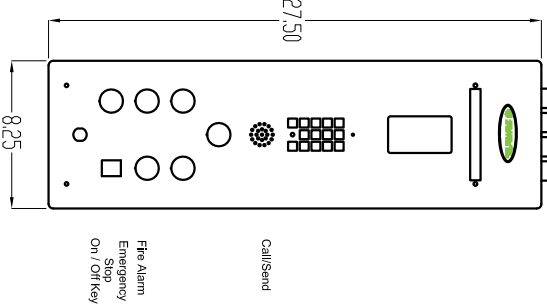
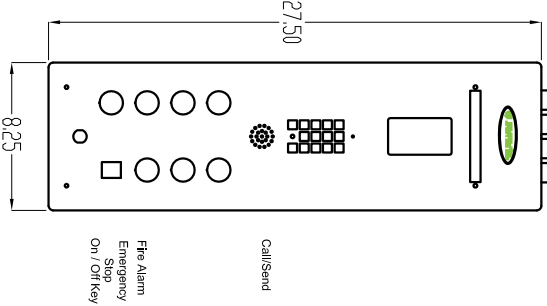
<p>C2P-12__STD</p>  <p>22.50</p> <p>8.25</p> <p>CallSend</p> <p>Fire Alarm Emergency Stop On / Off Key</p>	<p>C2P-123__STD</p>  <p>22.50</p> <p>8.25</p> <p>CallSend</p> <p>Fire Alarm Emergency Stop On / Off Key</p>	<p>C2P-1234__STD</p>  <p>22.50</p> <p>8.25</p> <p>CallSend</p> <p>Fire Alarm Emergency Stop On / Off Key</p>	<p>C2P-12345__STD</p>  <p>22.50</p> <p>8.25</p> <p>CallSend</p> <p>Fire Alarm Emergency Stop On / Off Key</p>	<p>C2P-123456__STD</p>  <p>22.50</p> <p>8.25</p> <p>CallSend</p> <p>Fire Alarm Emergency Stop On / Off Key</p>	<p>C2P-12__CST</p>  <p>27.50</p> <p>8.25</p> <p>CallSend</p> <p>Fire Alarm Emergency Stop On / Off Key</p>	<p>C2P-123__CST</p>  <p>27.50</p> <p>8.25</p> <p>CallSend</p> <p>Fire Alarm Emergency Stop On / Off Key</p>	<p>C2P-1234__CST</p>  <p>27.50</p> <p>8.25</p> <p>CallSend</p> <p>Fire Alarm Emergency Stop On / Off Key</p>	<p>C2P-12345__CST</p>  <p>27.50</p> <p>8.25</p> <p>CallSend</p> <p>Fire Alarm Emergency Stop On / Off Key</p>	<p>C2P-123456__CST</p>  <p>27.50</p> <p>8.25</p> <p>CallSend</p> <p>Fire Alarm Emergency Stop On / Off Key</p>
---	--	--	--	---	--	---	---	---	--

Hall call dimensions

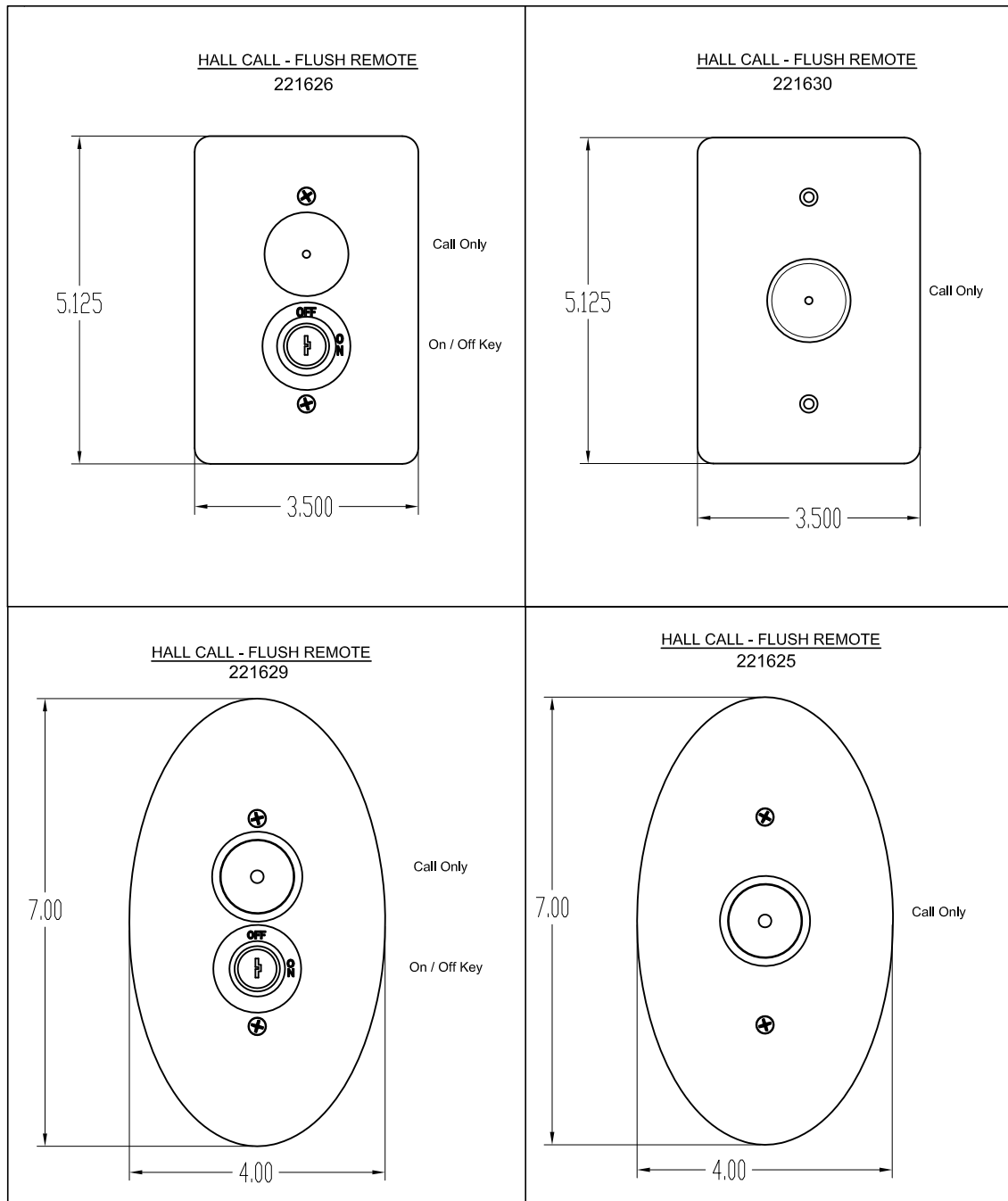

Appendix A

Infinity with Auto Slim Doors

This appendix provides elevation and plan view drawings for Infinity cabs with Auto Slim Doors. Drawings for the auto slim doors entrance assembly are provided on the next two pages.

Auto slim doors entrance assembly, CO = 2100

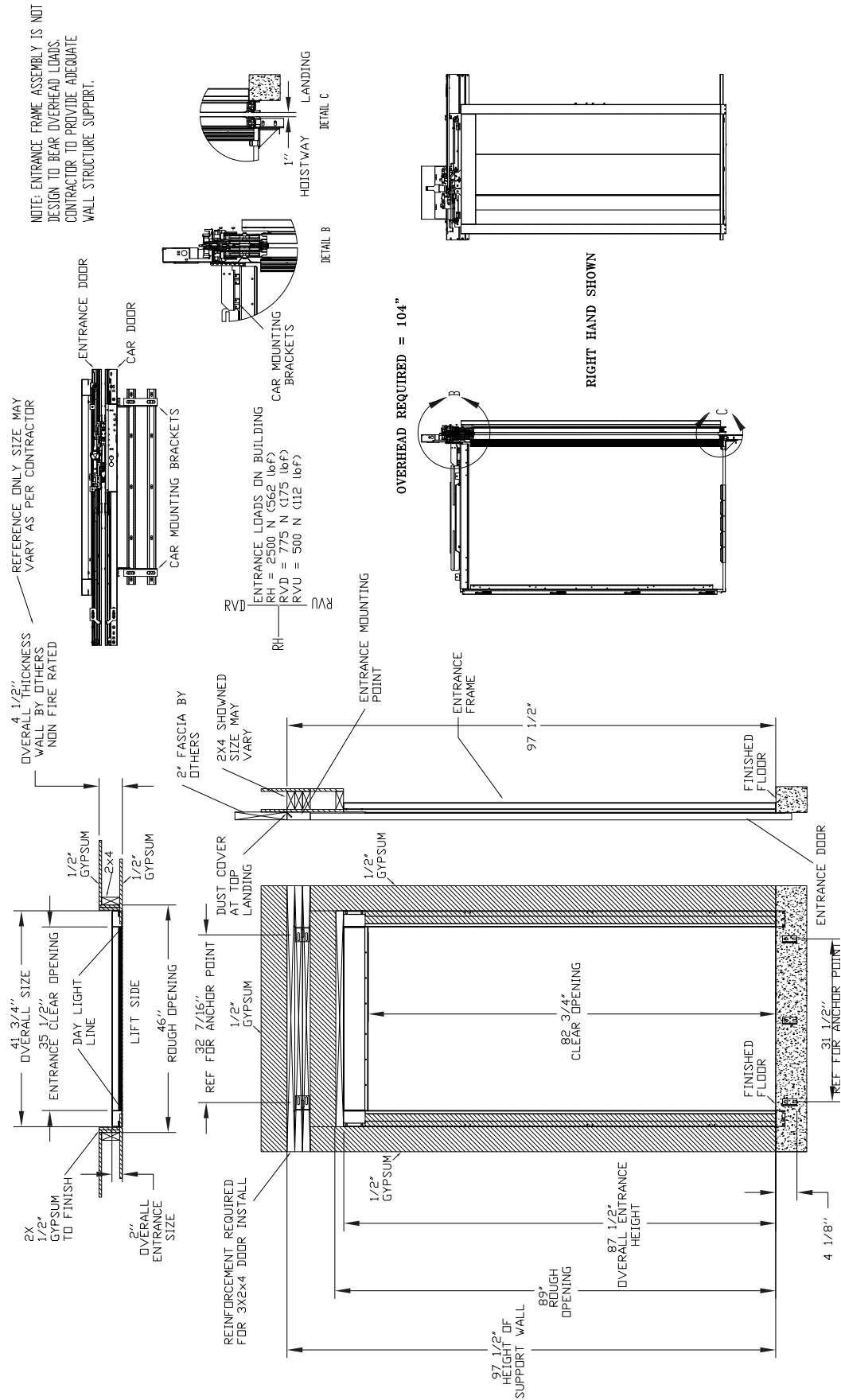

Elevation view – Infinity type 1L with auto slim doors

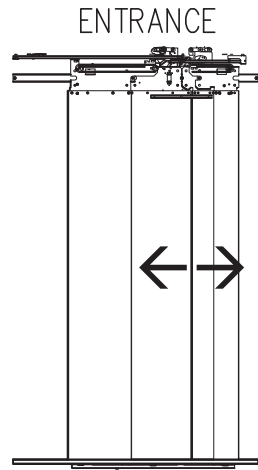
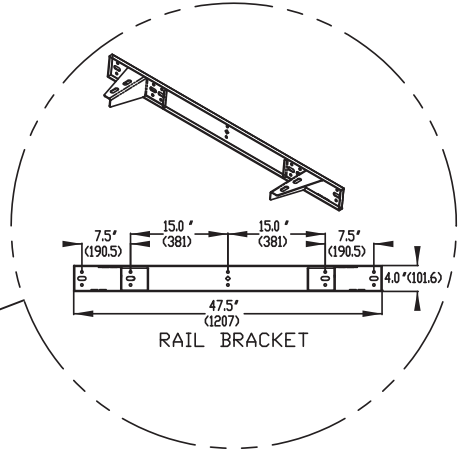
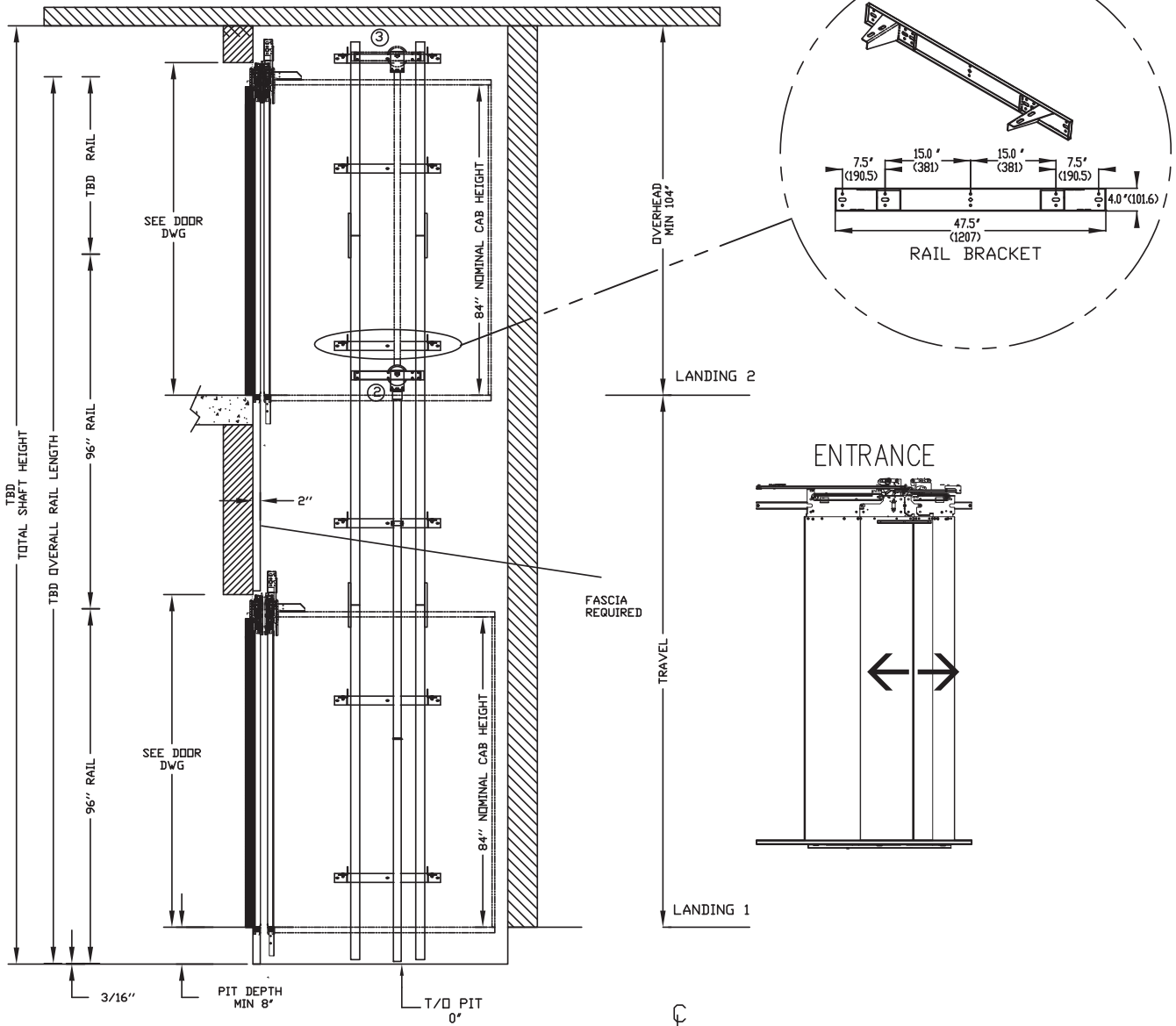

RAIL FORCES		R3 NOTE:
		PIT FLOOR TO SUPPORT LOAD OF: 5.6Klps * (INCLUDES IMPACT)
*R1	*R2	FOR TOTAL PULL-OUT FORCE ON RAIL BRACKET, R1 MUST BE DOUBLED eg.
304lbf.	194lbf.	
RAIL WEIGHT : 8.0 lbs / ft		

RAIL BRACKET

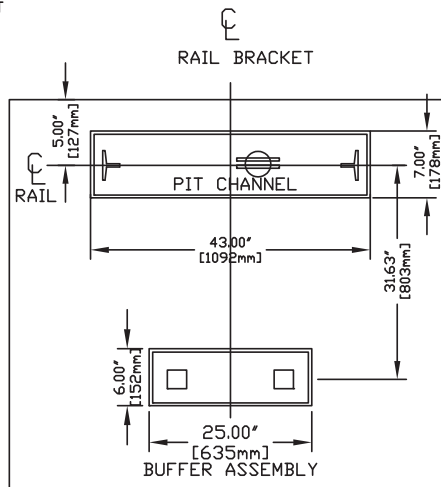

Plan view – Infinity type 1L with auto slim doors

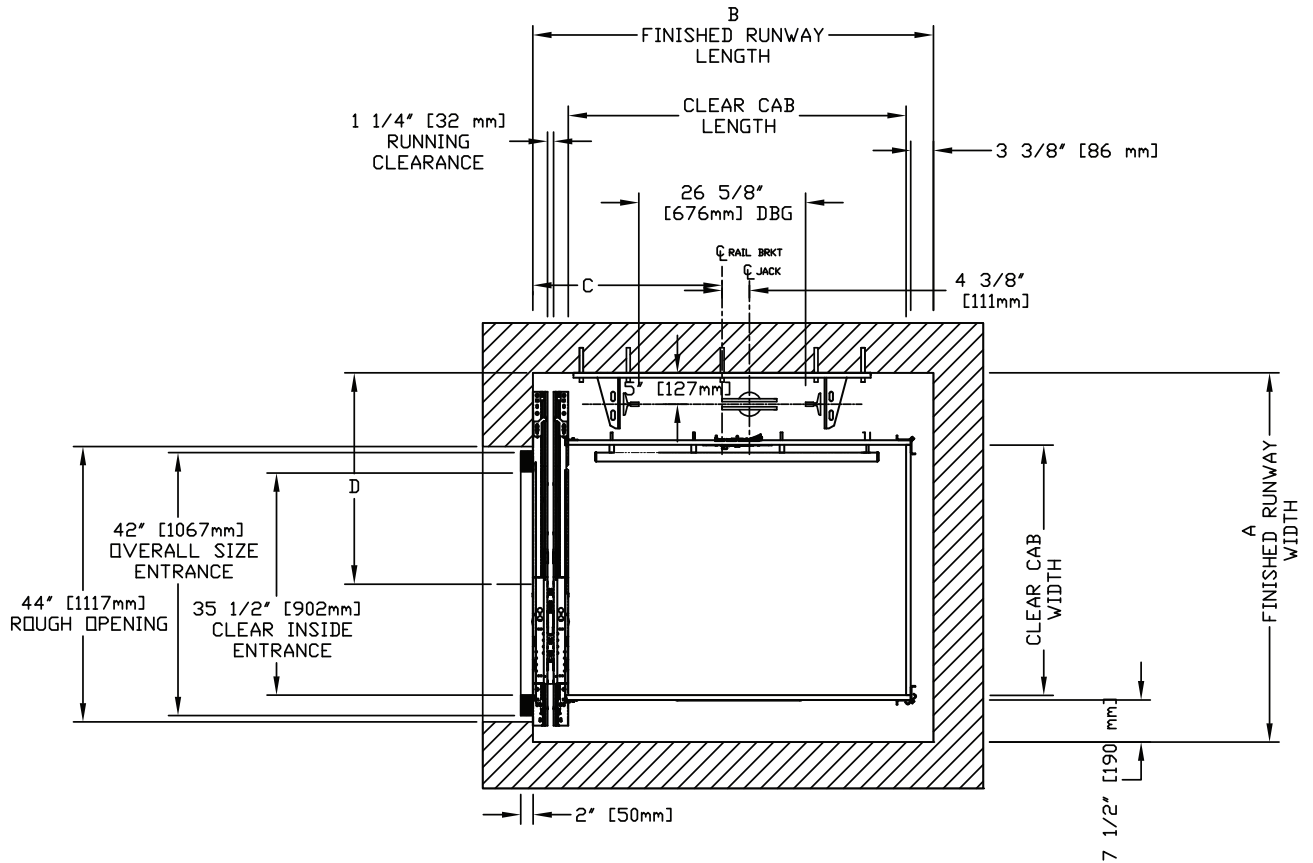

CLEAR INSIDE CAB WIDTH		CLEAR INSIDE CAB LENGTH		A FINISHED RUNWAY WIDTH		B FINISHED RUNWAY LENGTH		C RAIL CENTER LINE		D DOOR CENTER LINE	
mm	Inches	mm	Inches	mm	Inches	mm	Inches	mm	Inches	mm	Inches
914	36	1219	48	1499	59	1473	58	775	30.5	838	33.00
914	36	1372	54	1499	59	1626	64	826	32.5	838	33.00
914	36	1524	60	1499	59	1778	70	902	35.5	838	33.00
1016	40	1372	54	1524	60	1626	64	826	32.5	883	34 3/4
HD 1219	48	1524	60	1626	64	1778	70	914	36.0	857	33 3/4

Elevation view – Infinity type 1R with auto slim doors

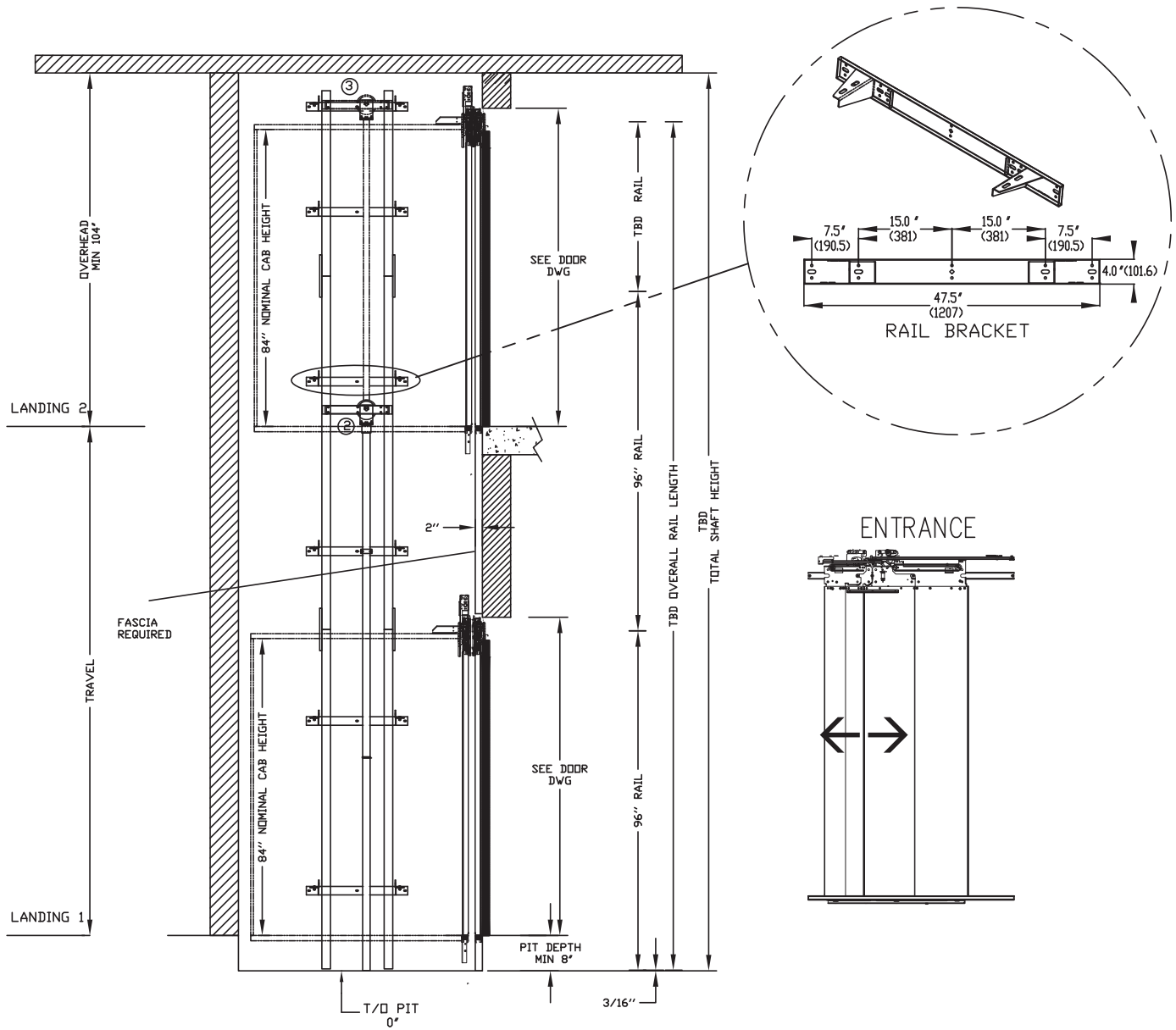

RAIL FORCES	
*R1	*R2
304lbf.	194lbf.
RAIL WEIGHT : 8.0 lbs / ft	

R3 NOTE:
 PIT FLOOR TO SUPPORT LOAD OF:
 5.6Kips * (INCLUDES IMPACT)
 FOR TOTAL PULL-OUT FORCE ON RAIL BRACKET,
 R1 MUST BE DOUBLED eg.

RAIL BRACKET

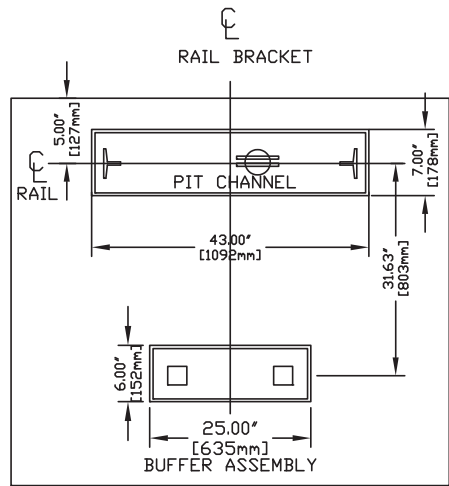

Plan view – Infinity type 1R with auto slim doors

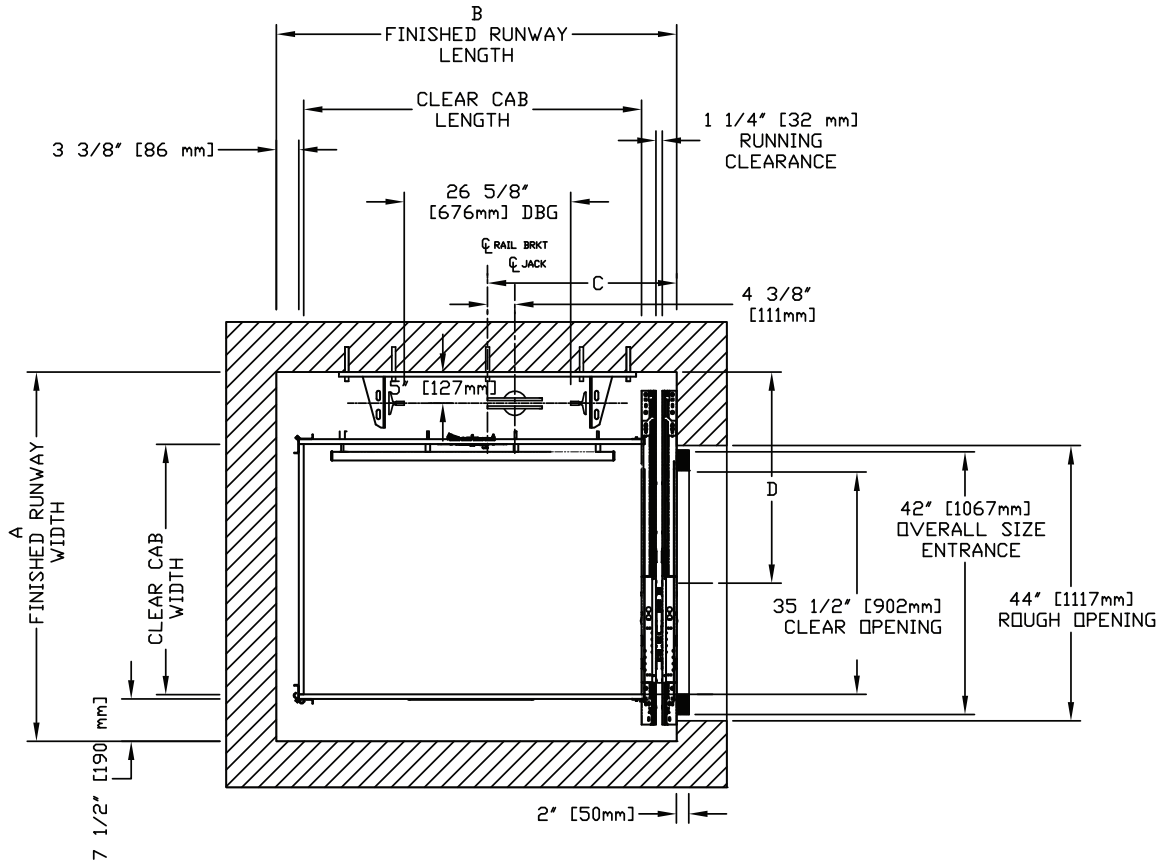

CLEAR INSIDE CAB WIDTH		CLEAR INSIDE CAB LENGTH		A FINISHED RUNWAY WIDTH		B FINISHED RUNWAY LENGTH		C RAIL CENTER LINE		D DOOR CENTER LINE	
mm	Inches	mm	Inches	mm	Inches	mm	Inches	mm	Inches	mm	Inches
914	36	1219	48	1499	59	1473	58	775	30.5	838	33.0
914	36	1372	54	1499	59	1626	64	826	32.5	838	33.0
914	36	1524	60	1499	59	1778	70	902	35.5	838	33.0
1016	40	1372	54	1524	60	1626	64	826	32.5	883	34 3/4
1219	48	1524	60	1626	64	1778	70	914	36.0	857	33 3/4

HD

Elevation view – Infinity type 2 with auto slim doors

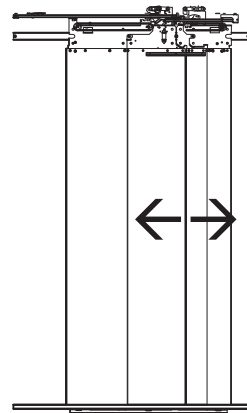
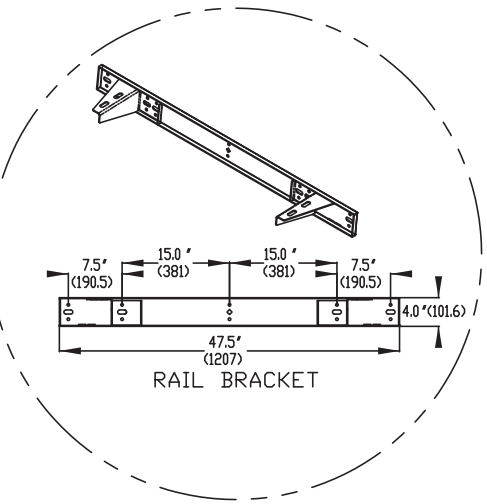
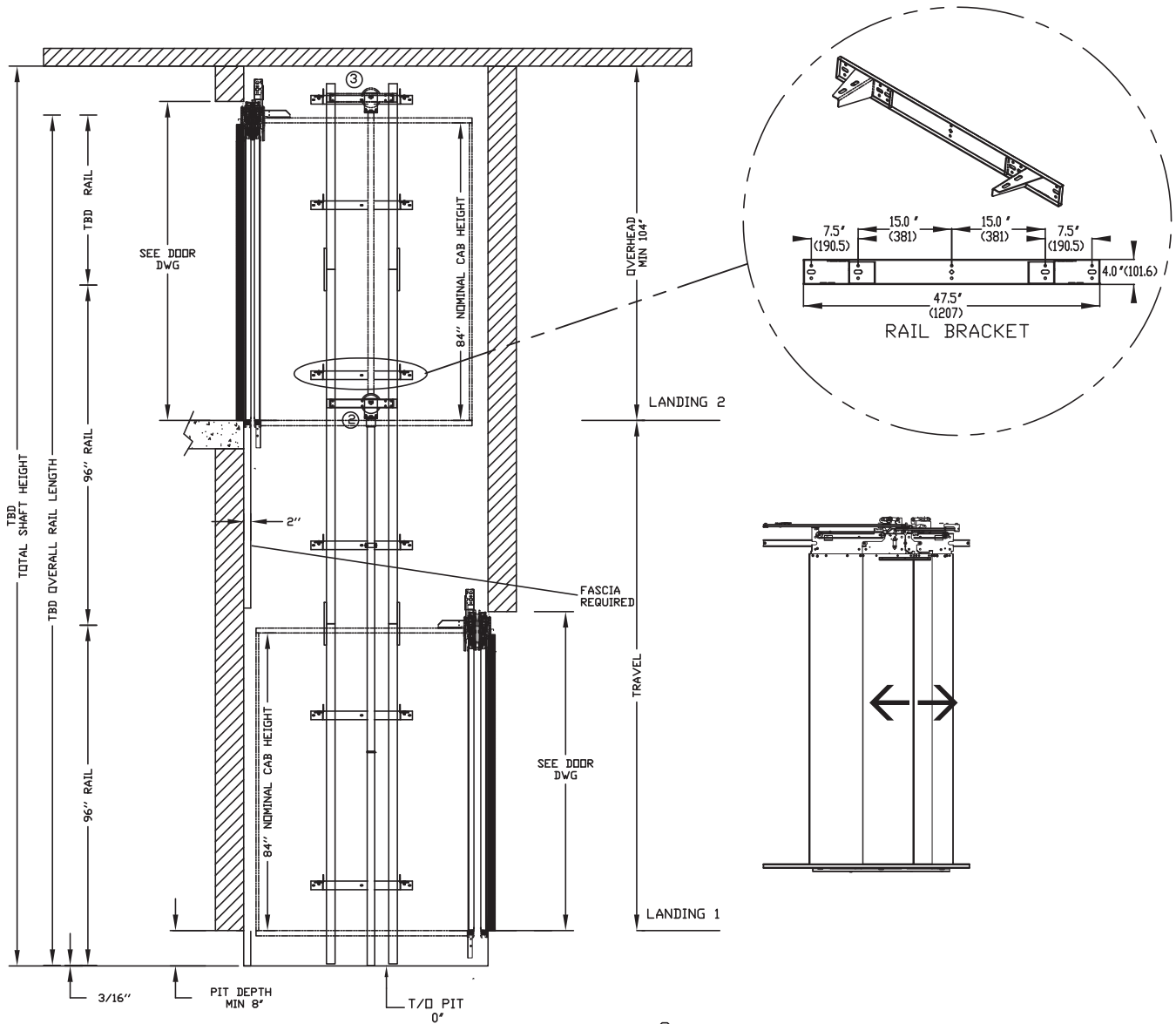

RAIL FORCES		R3 NOTE:
		PIT FLOOR TO SUPPORT LOAD OF: 5.6Kips * (INCLUDES IMPACT)
*R1	*R2	
304lbf.	194lbf.	FOR TOTAL PULL-OUT FORCE ON RAIL BRACKET, R1 MUST BE DOUBLED eg.
RAIL WEIGHT : 8.0 lbs / ft		

RAIL BRACKET

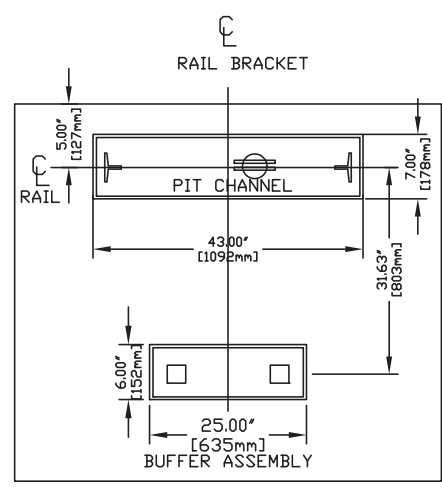

Plan view – Infinity type 2 with auto slim doors

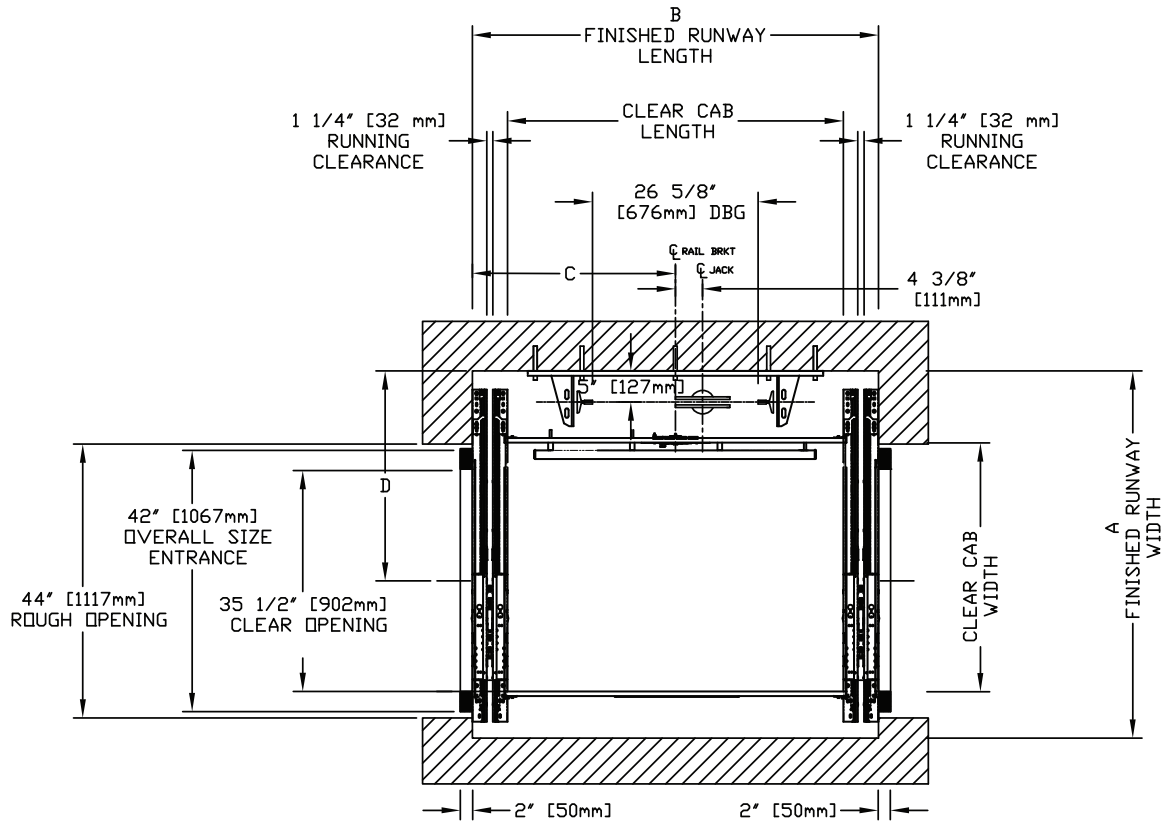

CLEAR INSIDE CAB WIDTH		CLEAR INSIDE CAB LENGTH		A FINISHED RUNWAY WIDTH		B FINISHED RUNWAY LENGTH		C RAIL CENTER LINE		D DOOR CENTER LINE	
mm	Inches	mm		mm	Inches	mm	Inches	mm	Inches	mm	Inches
914	36	1219	48	1499	59	1518	59 3/4	759	29 7/8	838	33.00
914	36	1372	54	1499	59	1670	65 3/4	835	32 7/8	838	33.00
914	36	1524	60	1499	59	1822	71 3/4	911	35 7/8	838	33.00
1016	40	1372	54	1524	60	1670	65 3/4	835	32 7/8	883	34 3/4
HD 1219	48	1524	60	1626	64	1803	71	902	35 1/2	857	33 3/4

Elevation view – Infinity type 3 with auto slim doors

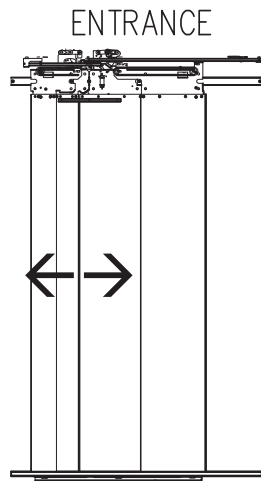
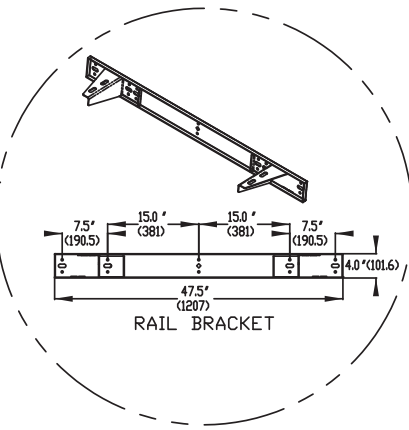
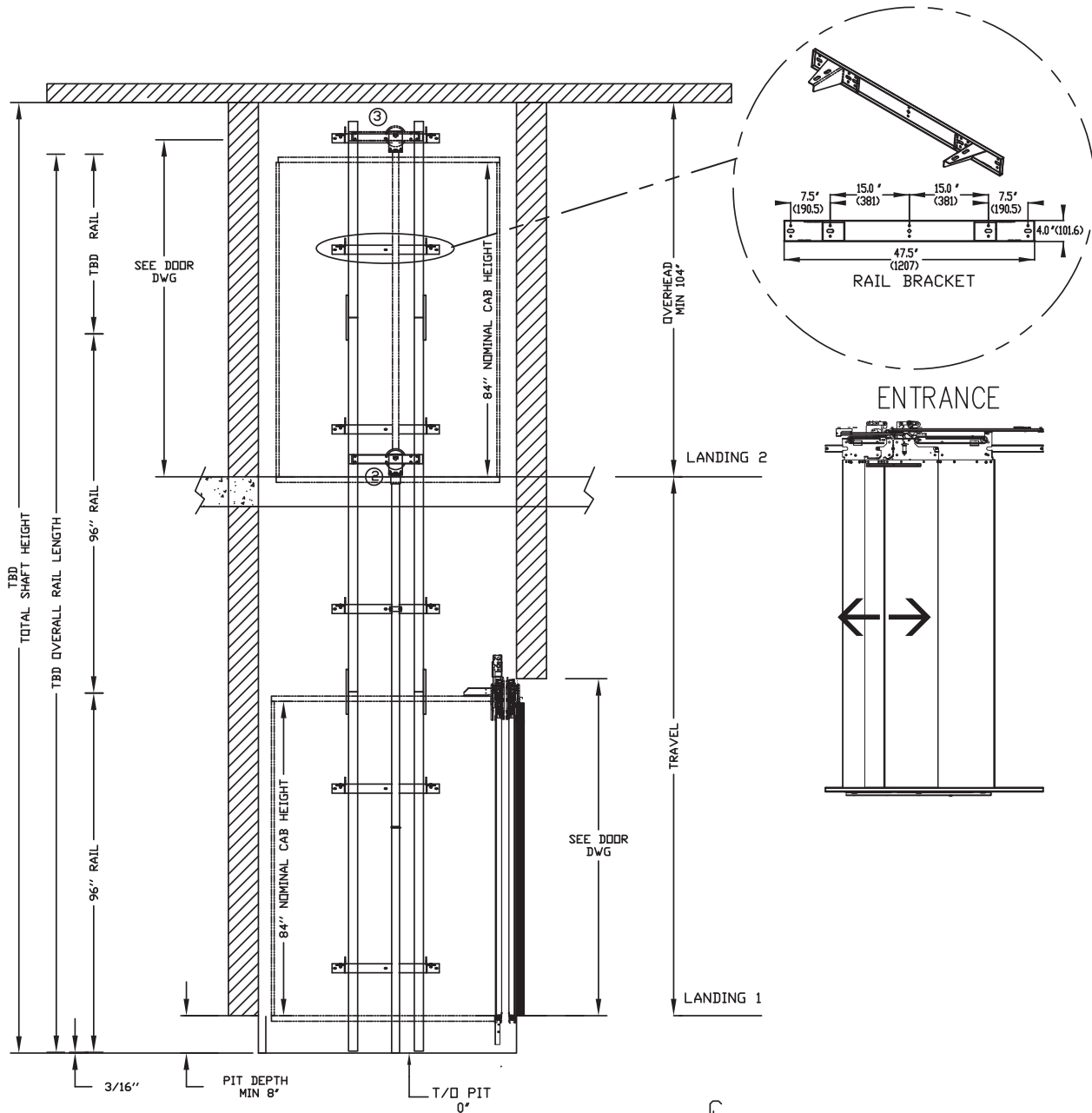

RAIL BRACKET

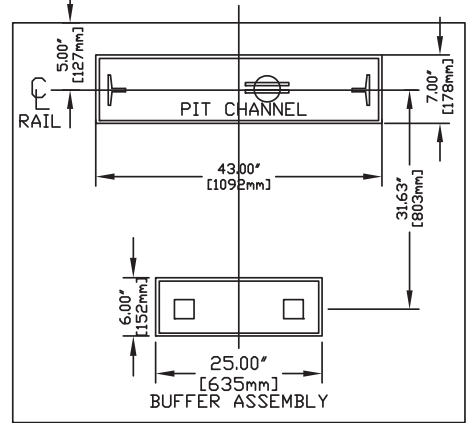

RAIL FORCES		R3 NOTE:
		PIT FLOOR TO SUPPORT LOAD OF: 5.6Klps * (INCLUDES IMPACT)
*R1	*R2	FOR TOTAL PULL-OUT FORCE ON RAIL BRACKET, R1 MUST BE DOUBLED eg.
304lbf.	194lbf.	
RAIL WEIGHT : 8.0 lbs / ft		

RAIL BRACKET

Plan view – Infinity type 3 with auto slim doors

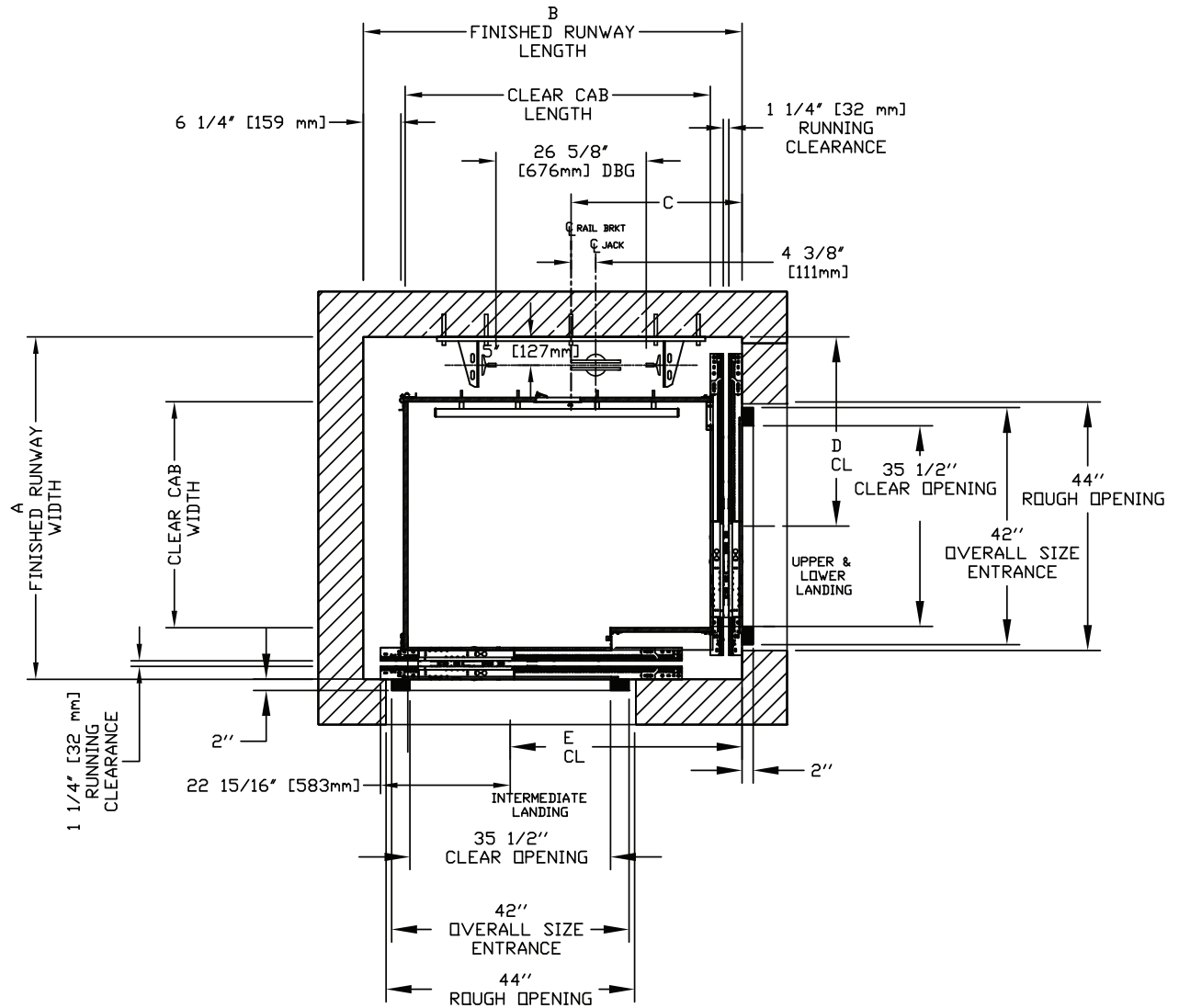

HD

CLEAR INSIDE CAB WIDTH		CLEAR INSIDE CAB LENGTH		A FINISHED RUNWAY WIDTH		B FINISHED RUNWAY LENGTH		C RAIL CENTER LINE		D DOOR CENTER LINE		E DOOR CENTER LINE	
mm	Inches	mm		mm	Inches	mm	Inches	mm	Inches	mm	Inches	mm	Inches
914	36	1372	54	1540	60 5/8	1702	67	826	32.5	838	33	1064	41 7/8
914	36	1524	60	1540	60 5/8	1854	73	902	35.5	838	33	1216	47 7/8
1016	40	1372	54	1581	62 1/4	1702	67	826	32.5	883	34 3/4	1064	41 7/8
1219	48	1524	60	1759	69 1/4	1778	70	889	35.0	857	33 3/4	768	30 1/4

Elevation view – Infinity type 4 with auto slim doors

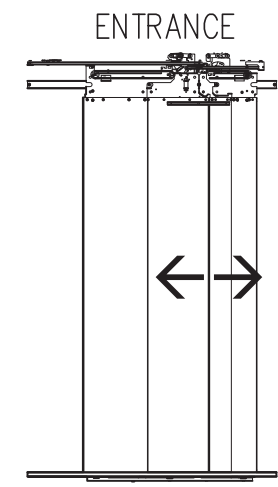
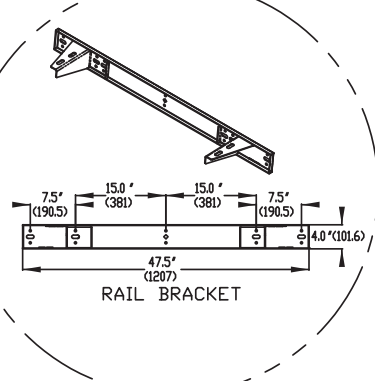
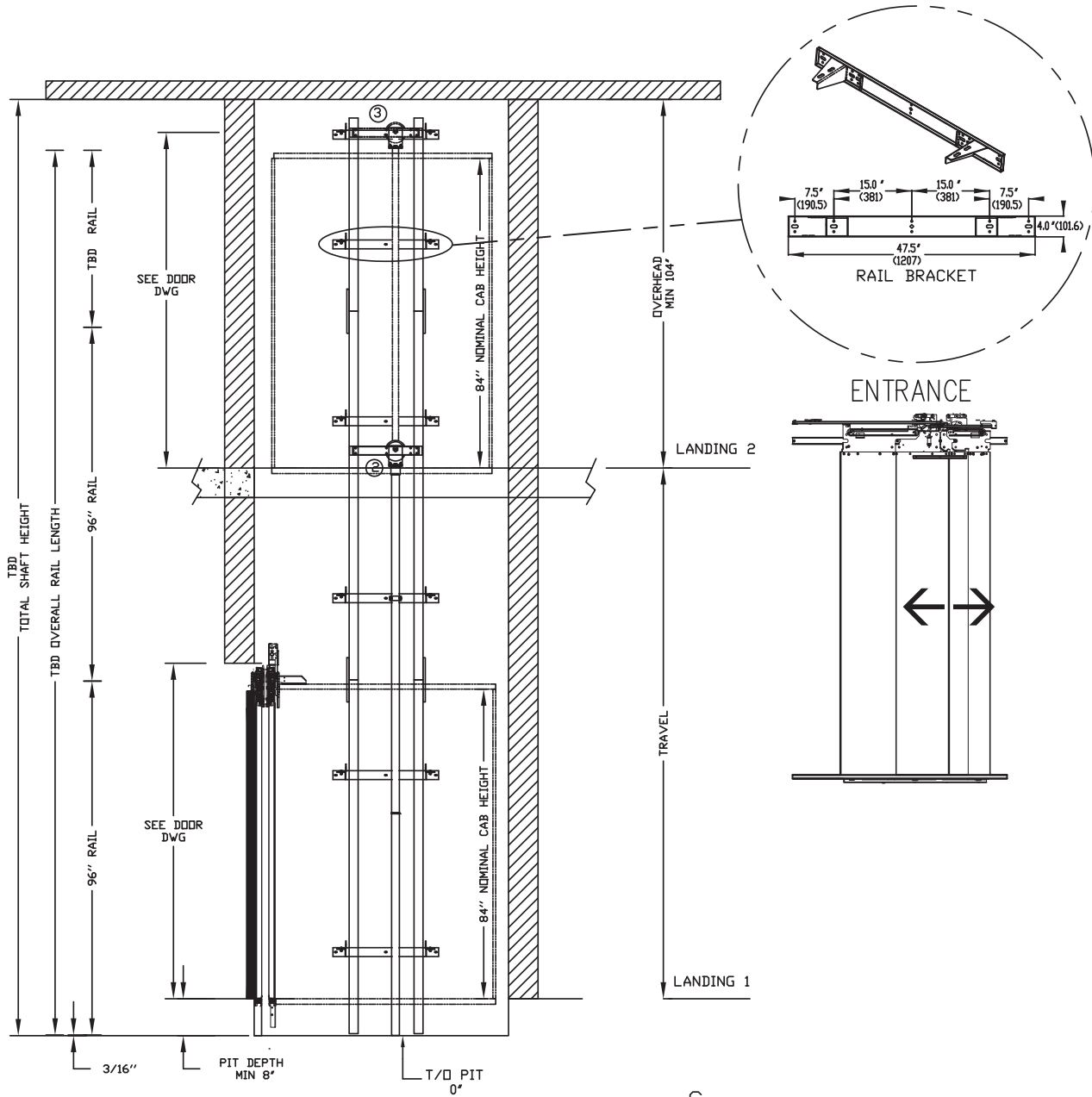

RAIL FORCES	
*R1	*R2
304lbf.	194lbf.
RAIL WEIGHT : 8.0 lbs / ft	

R3 NOTE:
 PIT FLOOR TO SUPPORT LOAD OF:
 5.6Kips * (INCLUDES IMPACT)
 FOR TOTAL PULL-OUT FORCE ON RAIL BRACKET,
 R1 MUST BE DOUBLED eg.

RAIL BRACKET

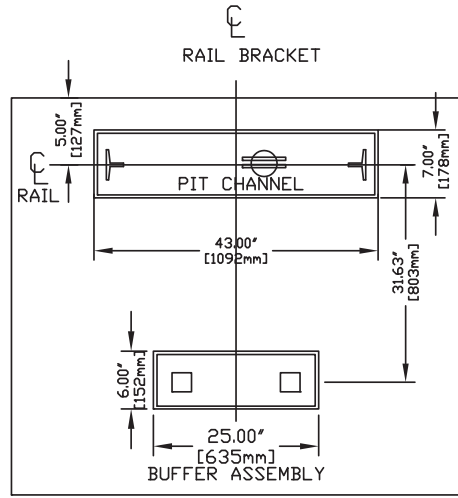

Plan view – Infinity type 4 with auto slim doors

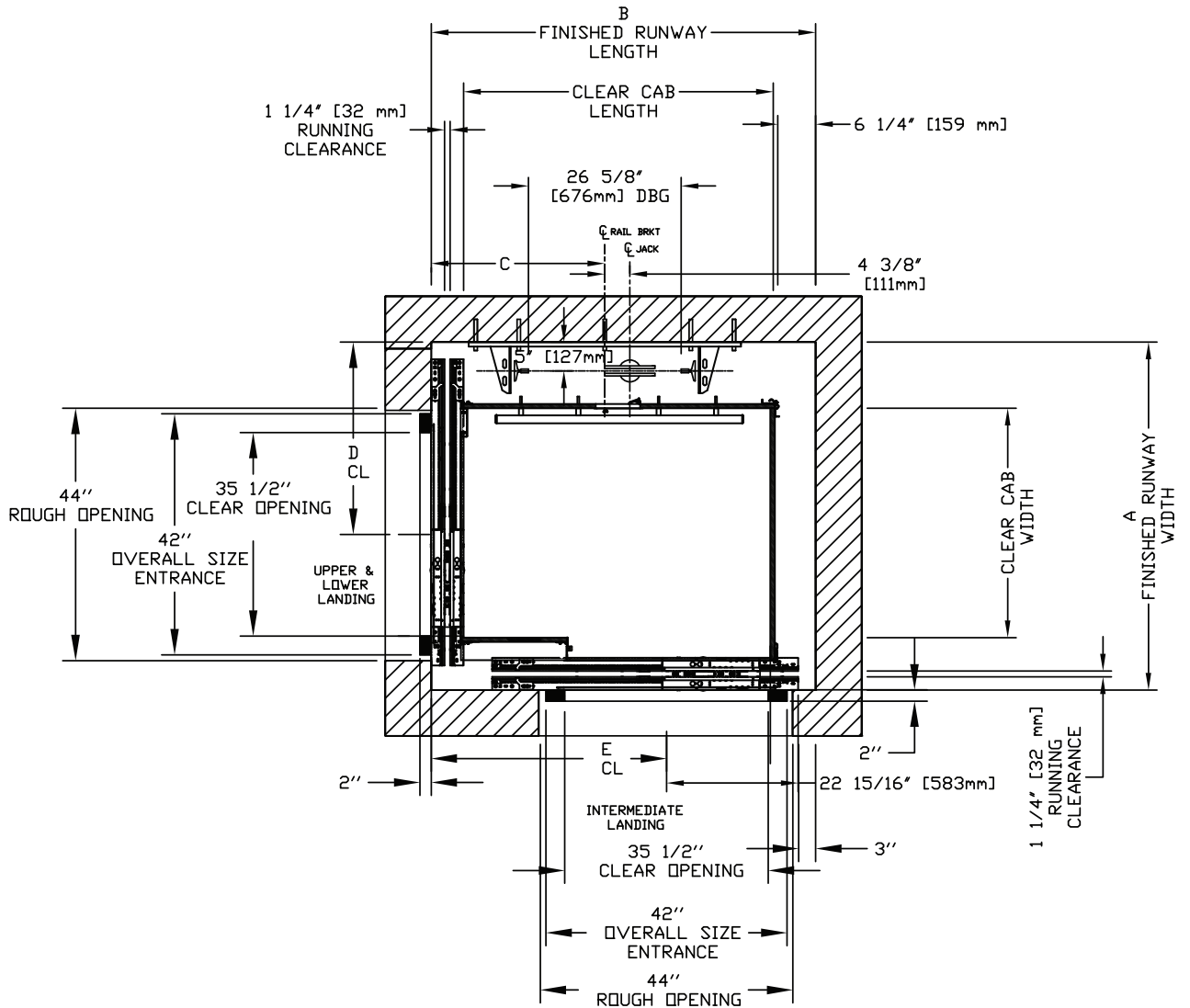

CLEAR INSIDE CAB WIDTH		CLEAR INSIDE CAB LENGTH		A FINISHED RUNWAY WIDTH		B FINISHED RUNWAY LENGTH		C RAIL CENTER LINE		D DOOR CENTER LINE		E DOOR CENTER LINE	
mm	Inches	mm		mm	Inches	mm	Inches	mm	Inches	mm	Inches	mm	Inches
914	36	1372	54	1540	60 5/8	1702	67	826	32 1/2	838	33	1064	41 7/8
914	36	1524	60	1540	60 5/8	1854	73	902	35 1/2	838	33	1216	47 7/8
1016	40	1372	54	1581	62 1/4	1702	67	826	32 1/2	883	34 3/4	1064	41 7/8
1219	48	1524	60	1759	69 1/4	1778	70	889	35	857	33 3/4	768	30 1/4

HD

Elevation view – Infinity type 5 with auto slim doors

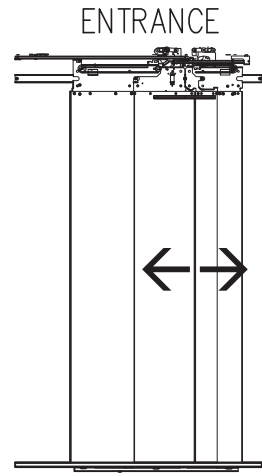
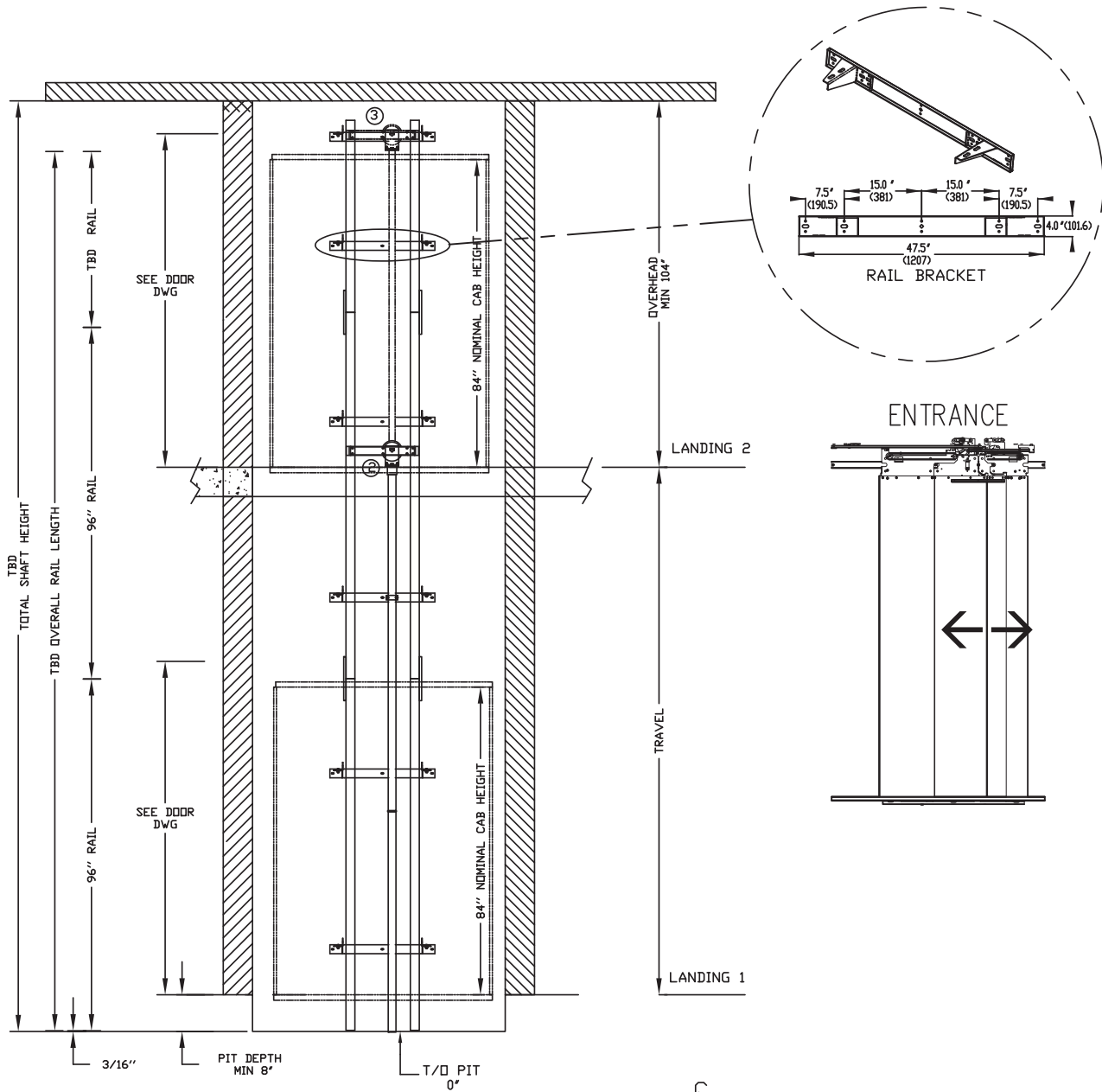

RAIL FORCES	
*R1	*R2
304lbf.	194lbf.
RAIL WEIGHT : 8.0 lbs / ft	

R3 NOTE:
 PIT FLOOR TO SUPPORT LOAD OF:
 5.6Kips * (INCLUDES IMPACT)
 FOR TOTAL PULL-OUT FORCE ON RAIL BRACKET,
 R1 MUST BE DOUBLED eg.

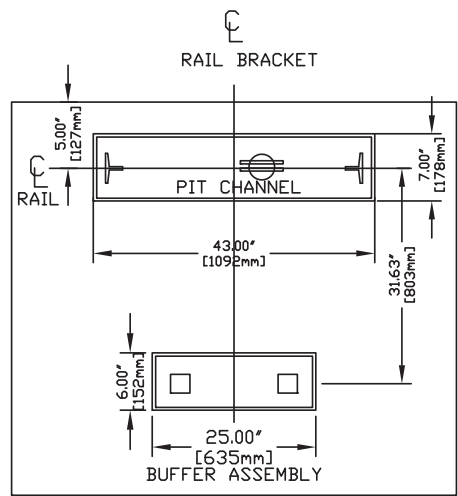

RAIL BRACKET

Plan view – Infinity type 5 with auto slim doors

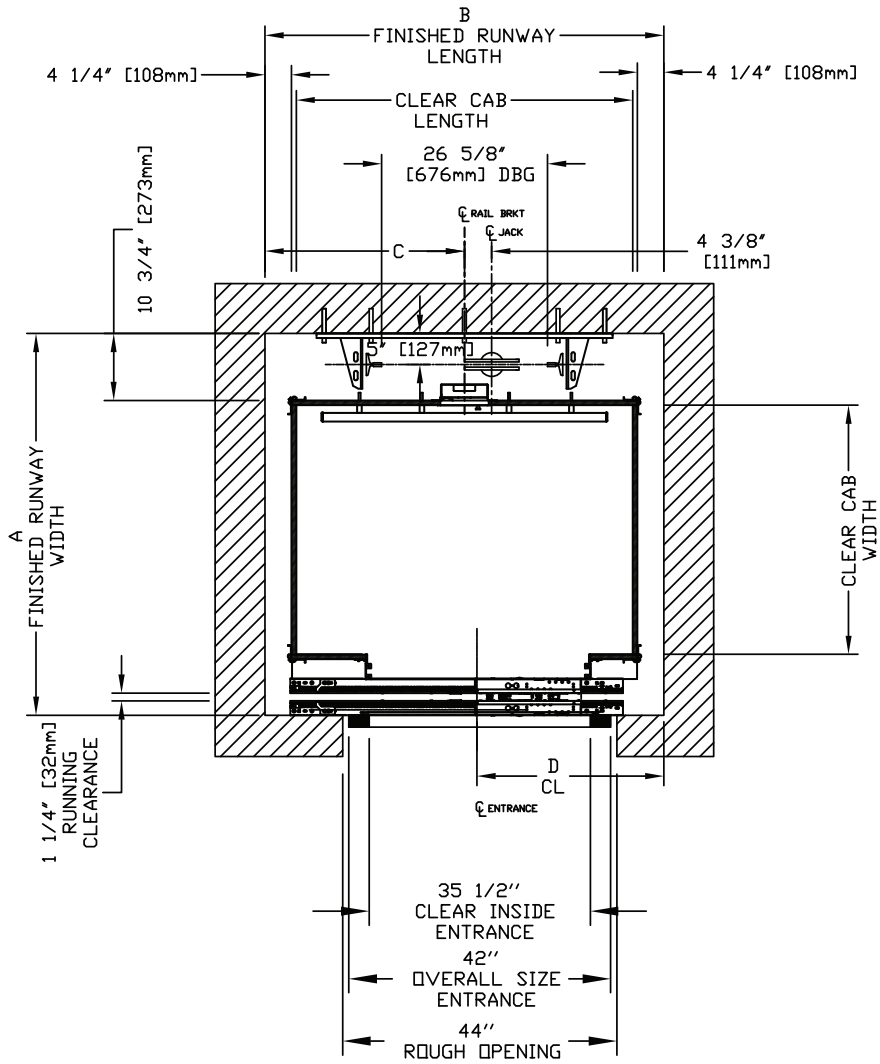

CLEAR INSIDE CAB WIDTH		CLEAR INSIDE CAB LENGTH		A FINISHED RUNWAY WIDTH		B FINISHED RUNWAY LENGTH		C RAIL CENTER LINE		D DOOR CENTER LINE	
mm	Inches	mm		mm	Inches	mm	Inches	mm	Inches	mm	Inches
914	36	1372	54	1454	57 1/4	1626	64	813	32	762	30
914	36	1524	60	1454	57 1/4	1778	70	889	35	762	30
1016	40	1372	54	1556	61 1/4	1626	64	813	32	762	30
HD 1219	48	1524	60	1759	69 1/4	1778	70	889	35	889	35

Appendix B

Infinity with Bi-fold Doors

This appendix provides elevation and plan view drawings for Infinity cabs with Bi-fold Doors.

Elevation view – Infinity type 1L with bi-fold doors

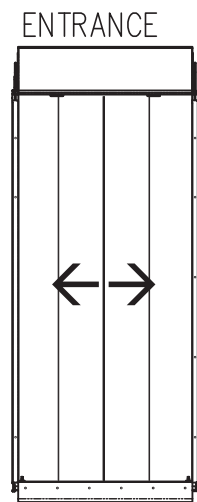
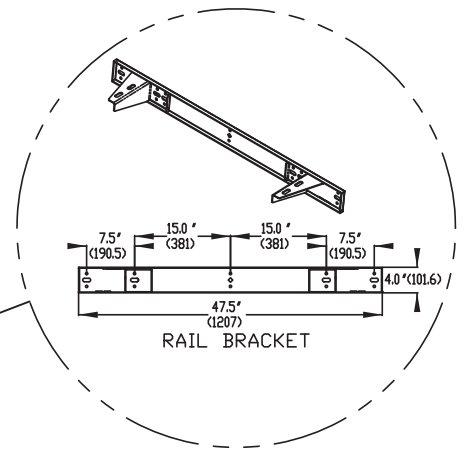
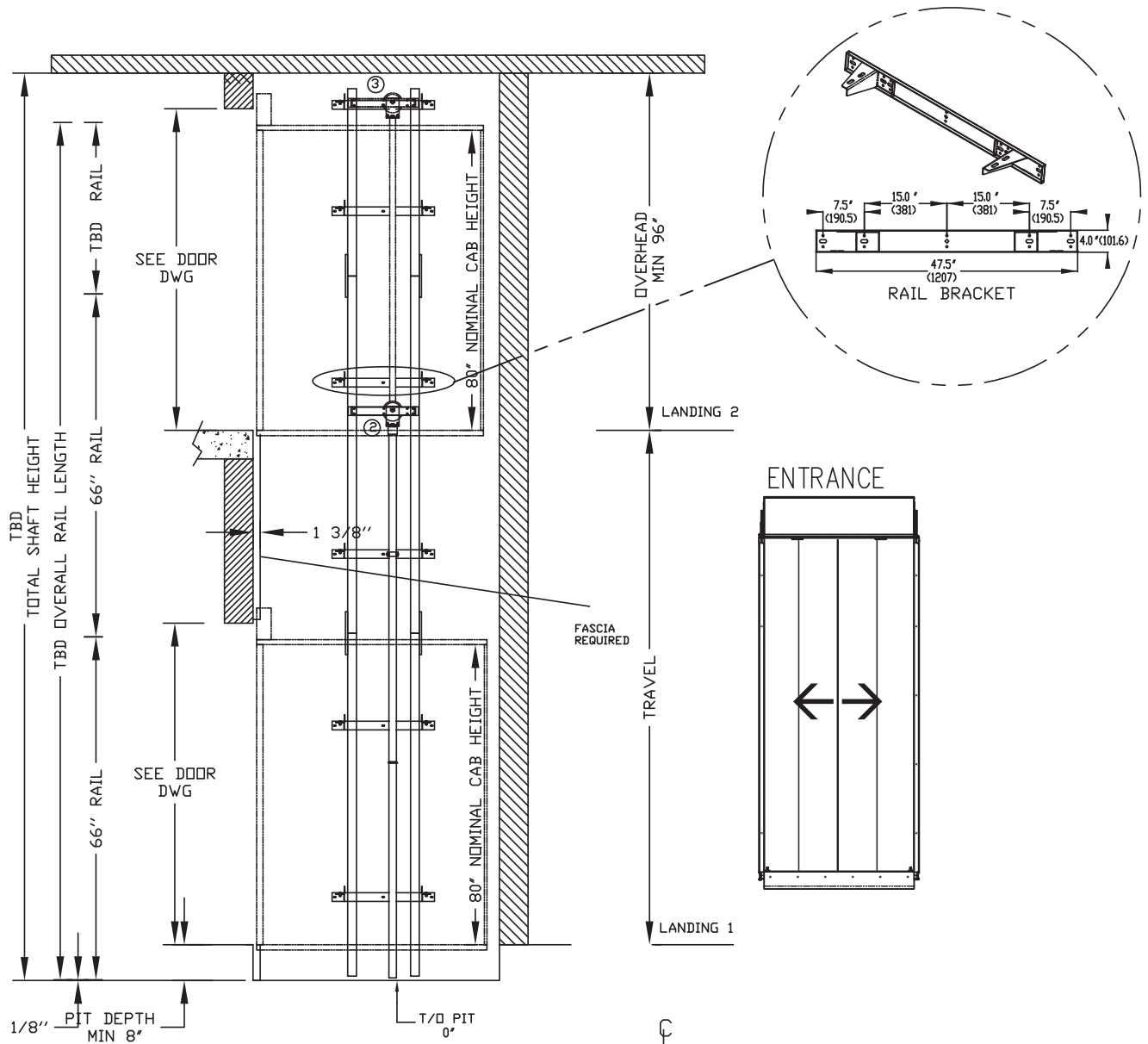

RAIL FORCES	
*R1	*R2
304lb.f.	194lb.f.
RAIL WEIGHT : 8.0 lbs / ft	

R3 NOTE:
 PIT FLOOR TO SUPPORT LOAD OF:
 5.6Klbs * (INCLUDES IMPACT)
 FOR TOTAL PULL-OUT FORCE ON RAIL BRACKET,
 R1 MUST BE DOUBLED eg.

RAIL BRACKET

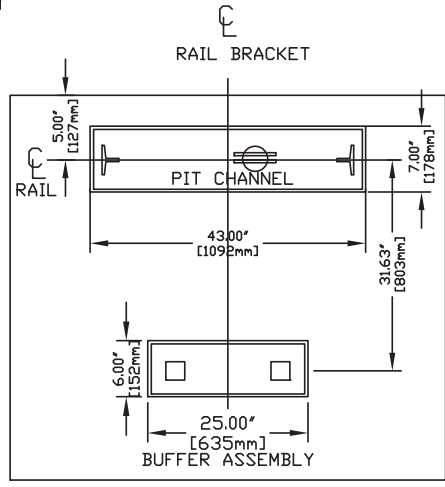

Plan view – Infinity type 1L with bi-fold doors (36" cab width)

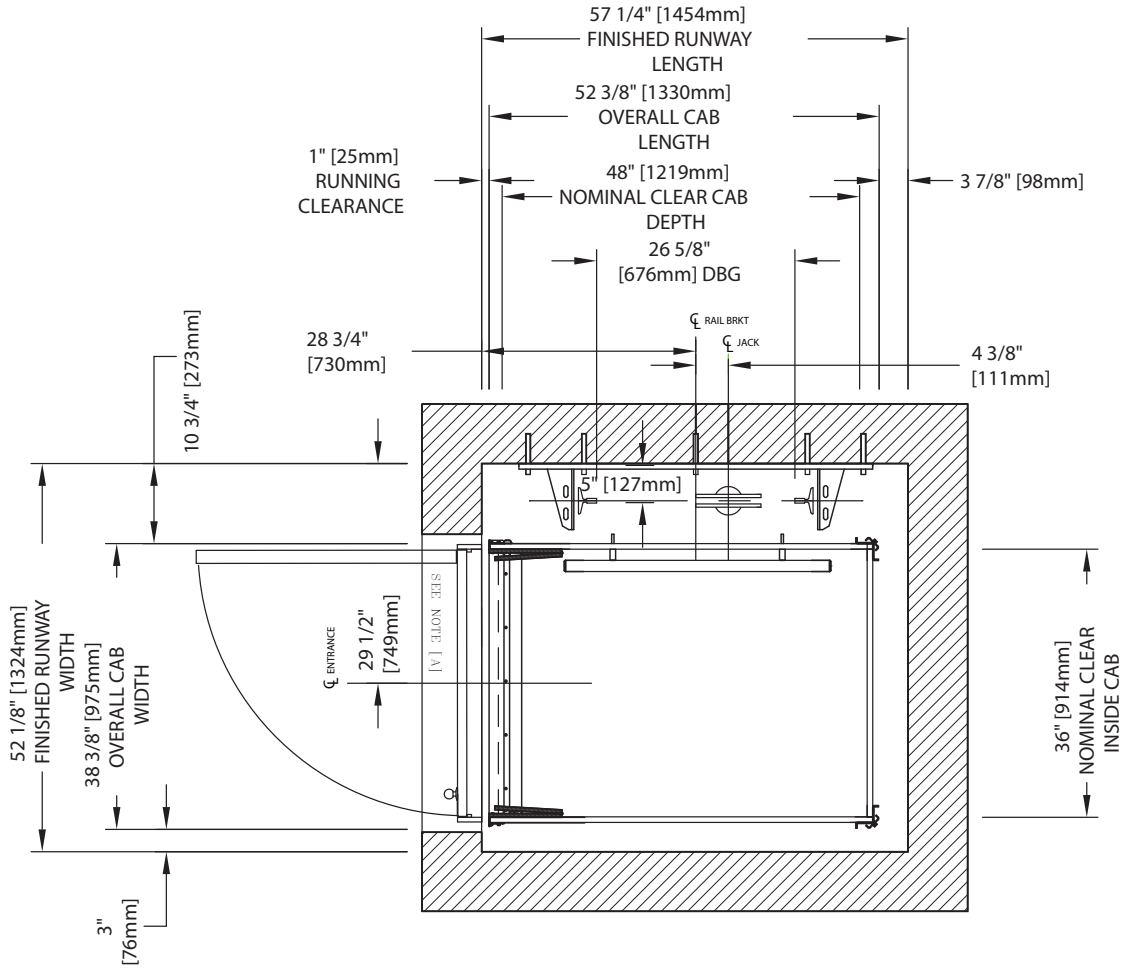

NOMINAL CLEAR INSIDE CAB WIDTH		NOMINAL CLEAR INSIDE CAB LENGTH		A FINISHED RUNWAY WIDTH		B FINISHED RUNWAY LENGTH		C RAIL CENTRE LINE		D DOOR CENTER LINE	
mm	inches	mm		mm	inches	mm	inches	mm	inches	mm	inches
914	36	1219	48	1324	52 1/8	1454	57 1/2	711	28	749	29 1/2
914	36	1372	54	1324	52 1/8	1607	63 1/4	768	30 1/4	749	29 1/2
914	36	1524	60	1324	52 1/8	1759	60 1/4	845	33 1/4	749	29 1/2

Plan view – Infinity type 1L with bi-fold doors (40" cab width)

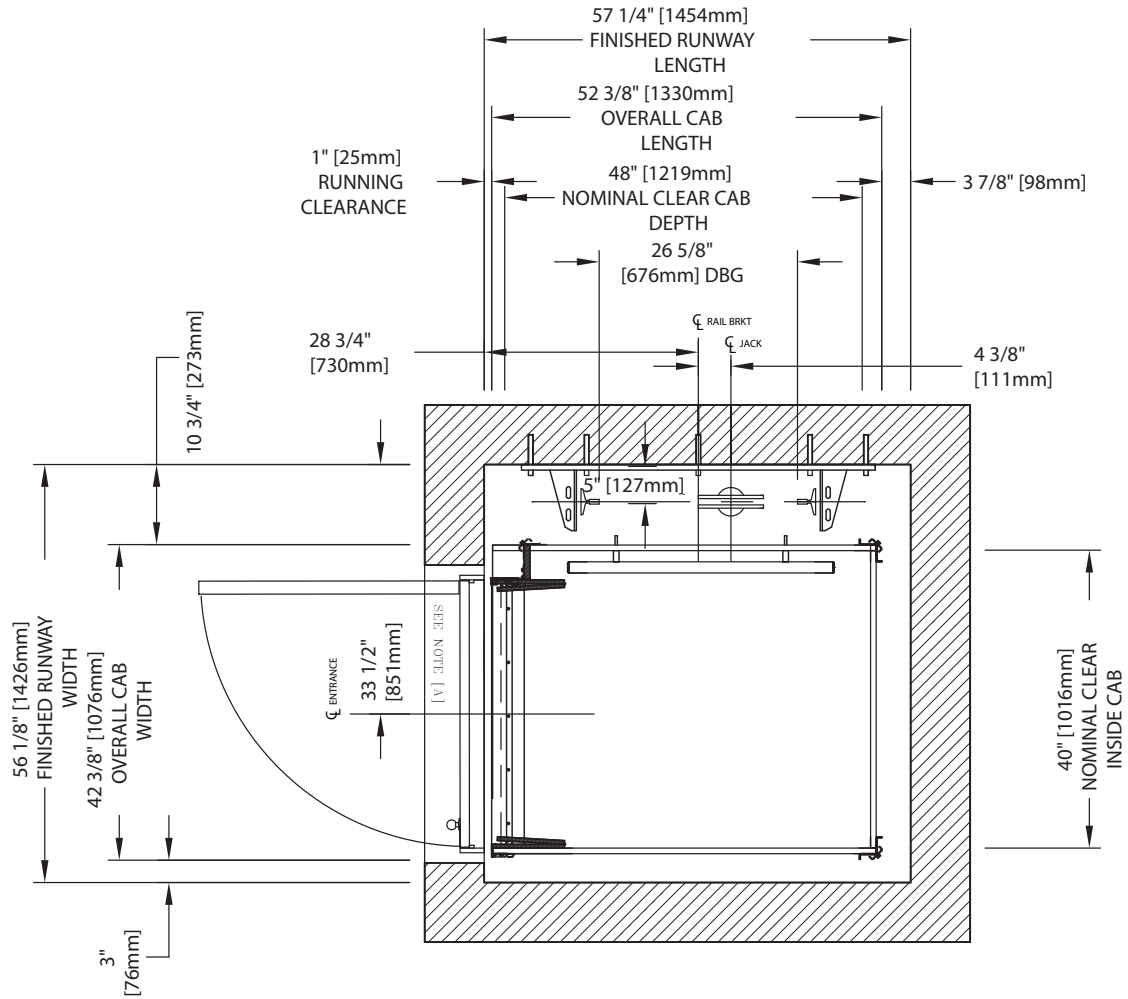

NOMINAL CLEAR INSIDE CAB WIDTH		NOMINAL CLEAR INSIDE CAB LENGTH		A FINISHED RUNWAY WIDTH		B FINISHED RUNWAY LENGTH		C RAIL CENTRE LINE		D DOOR CENTER LINE	
mm	inches	mm		mm	inches	mm	inches	mm	inches	mm	inches
1016	40	1219	48	1426	56 1/8	1454	57 1/2	711	28	851	33 1/2
1016	40	1372	54	1426	56 1/8	1607	63 1/4	768	30 1/4	851	33 1/2
1016	40	1524	60	1426	56 1/8	1759	60 1/4	845	33 1/4	851	33 1/2

Elevation view – Infinity type 1R with bi-fold doors

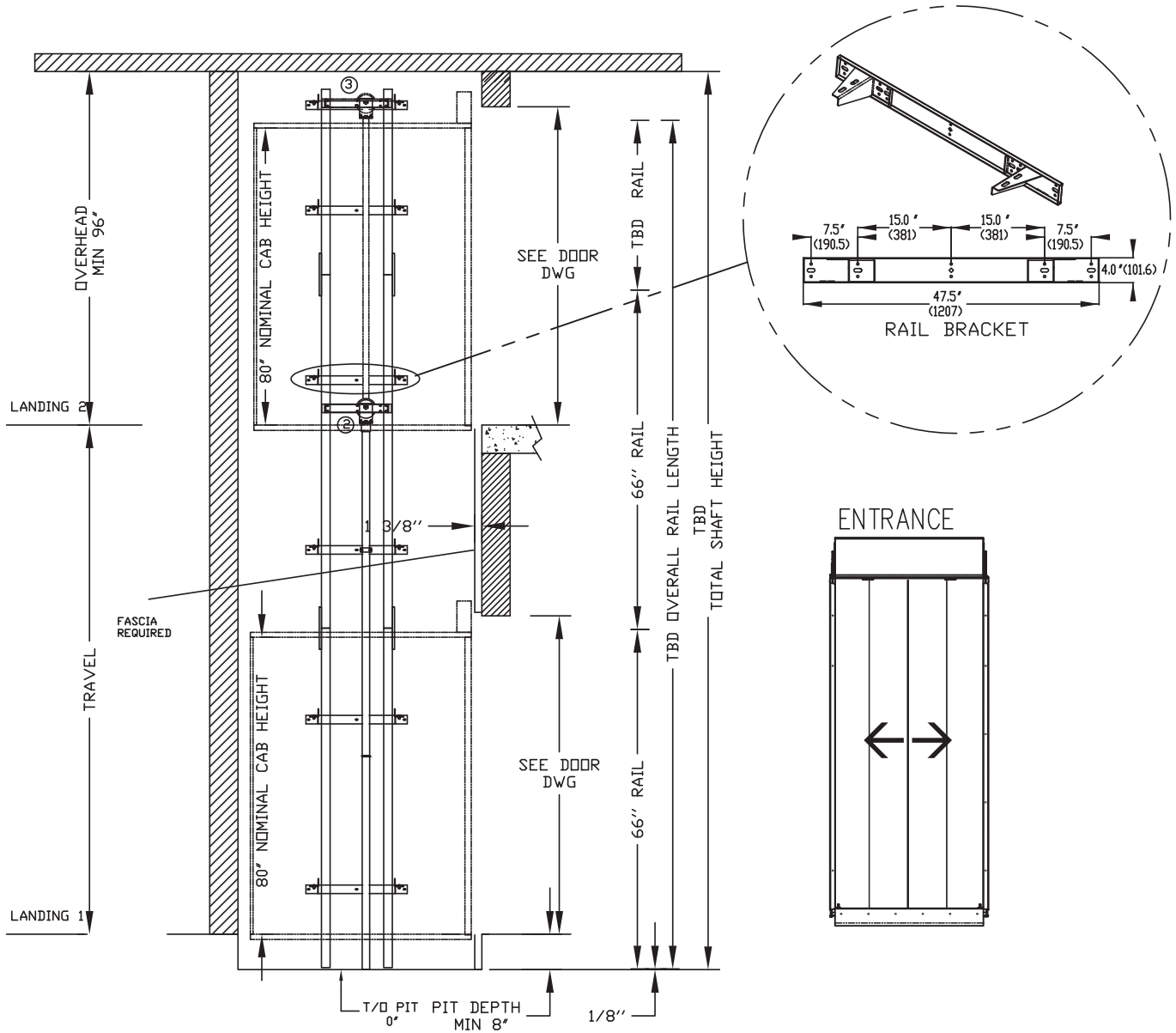

RAIL FORCES	
*R1	*R2
304lbf.	194lbf.
RAIL WEIGHT : 8.0 lbs / ft	

R3 NOTE:
 PIT FLOOR TO SUPPORT LOAD OF:
 5.6Klps * (INCLUDES IMPACT)
 FOR TOTAL PULL-OUT FORCE ON RAIL BRACKET,
 R1 MUST BE DOUBLED eg.

RAIL BRACKET

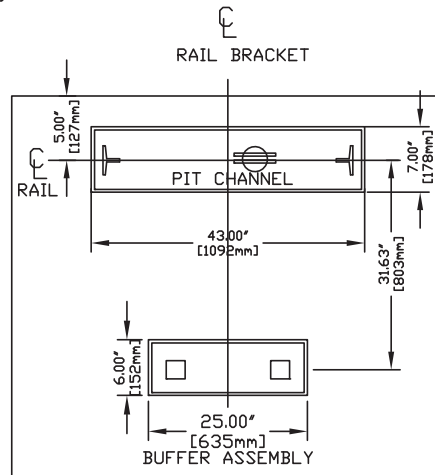

Plan view – Infinity type 1R with bi-fold doors (36" cab width)

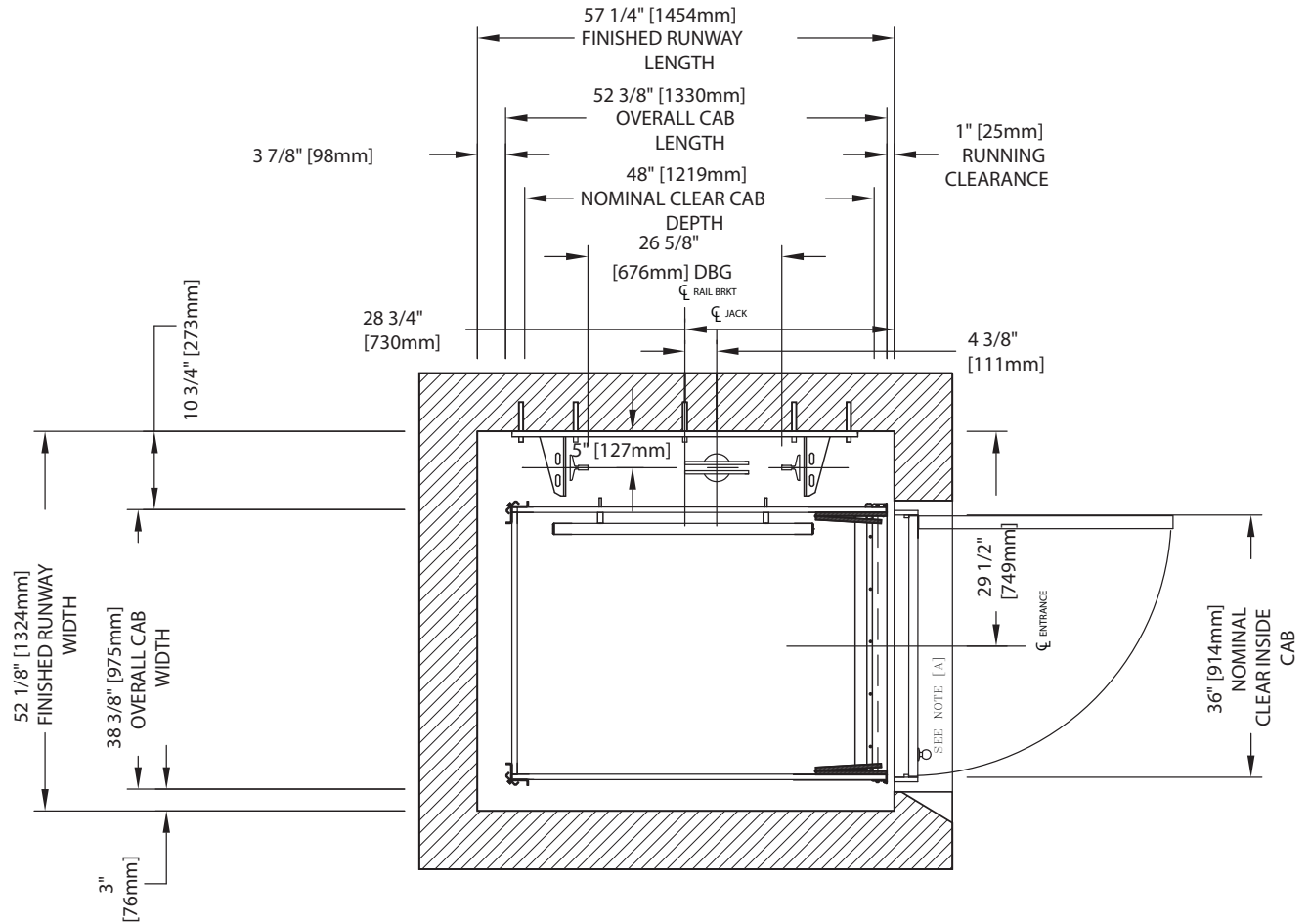

NOMINAL CLEAR INSIDE CAB WIDTH		NOMINAL CLEAR INSIDE CAB LENGTH		A FINISHED RUNWAY WIDTH		B FINISHED RUNWAY LENGTH		C RAIL CENTRE LINE		D DOOR CENTER LINE	
mm	inches	mm		mm	inches	mm	inches	mm	inches	mm	inches
914	36	1219	48	1324	52 1/8	1454	57 1/2	711	28	749	29 1/2
914	36	1372	54	1324	52 1/8	1607	63 1/4	768	30 1/4	749	29 1/2
914	36	1524	60	1324	52 1/8	1759	60 1/4	845	33 1/4	749	29 1/2

Plan view – Infinity type 1R with bi-fold doors (40" cab width)

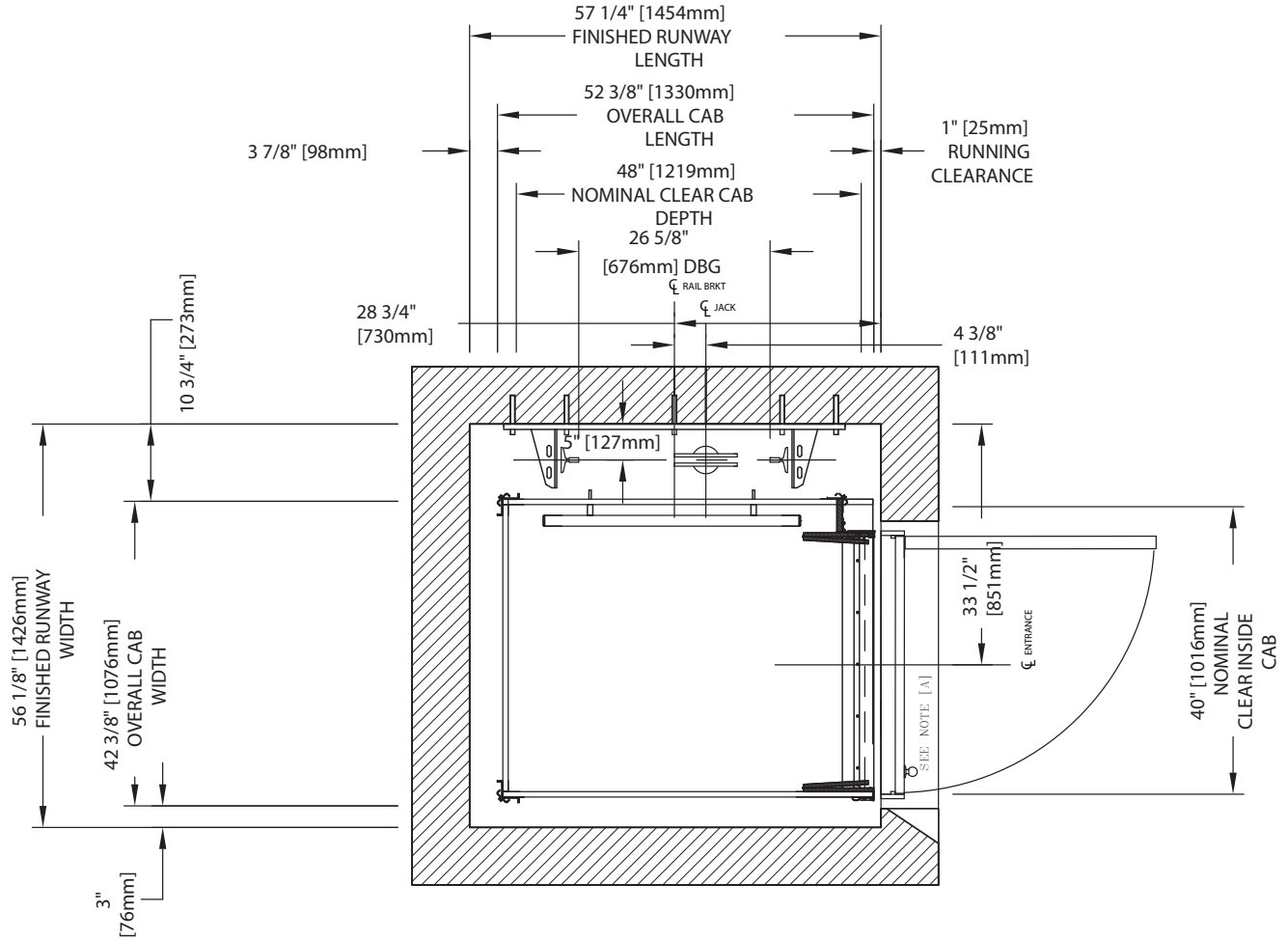

NOMINAL CLEAR INSIDE CAB WIDTH		NOMINAL CLEAR INSIDE CAB LENGTH		A FINISHED RUNWAY WIDTH		B FINISHED RUNWAY LENGTH		C RAIL CENTRE LINE		D DOOR CENTER LINE	
mm	inches	mm		mm	inches	mm	inches	mm	inches	mm	inches
1016	40	1219	48	1426	56 1/8	1454	57 1/2	711	28	851	33 1/2
1016	40	1372	54	1426	56 1/8	1607	63 1/4	768	30 1/4	851	33 1/2
1016	40	1524	60	1426	56 1/8	1759	60 1/4	845	33 1/4	851	33 1/2

Elevation view – Infinity type 2 with bi-fold doors

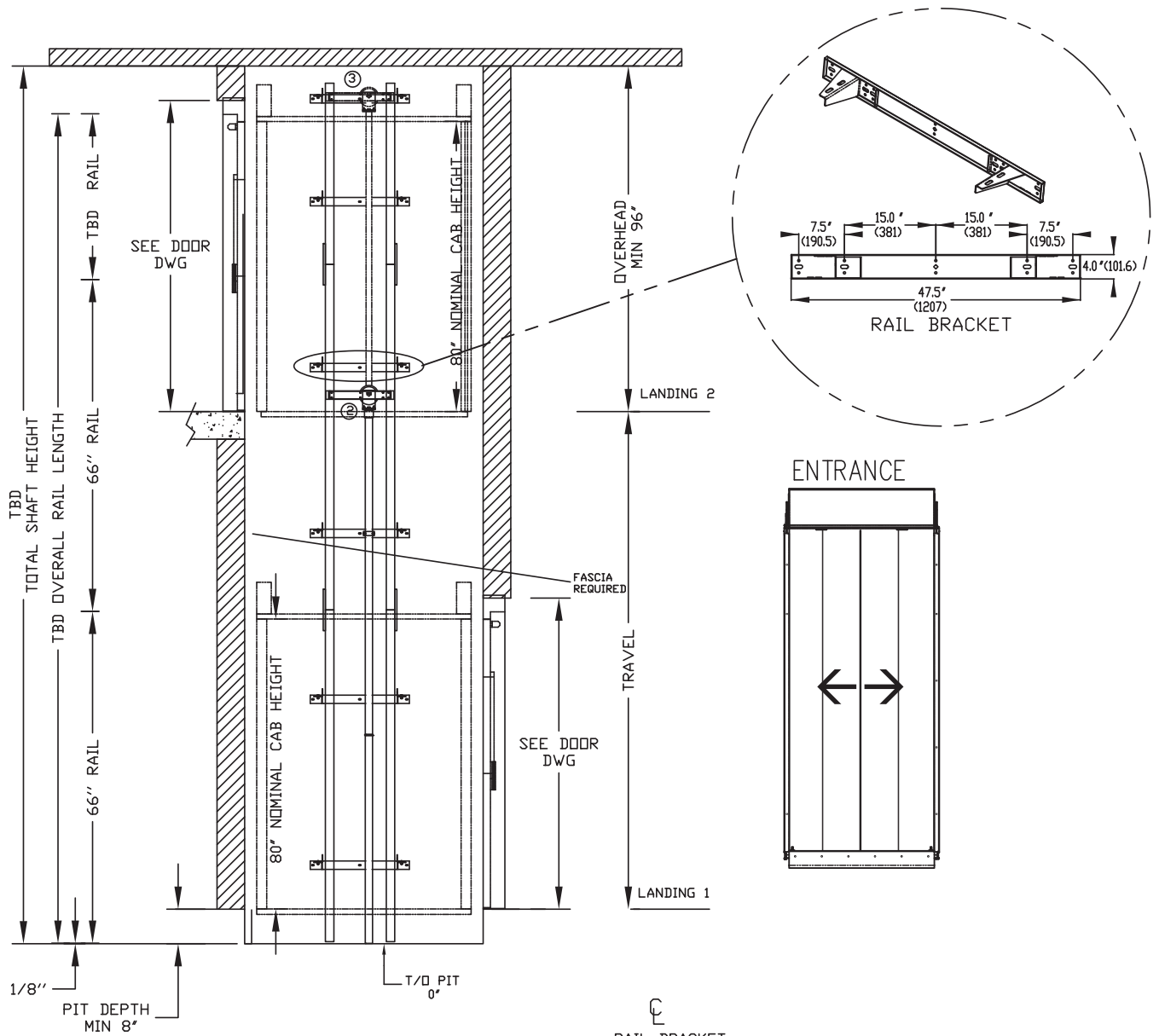

RAIL FORCES		R3 NOTE:
		PIT FLOOR TO SUPPORT LOAD OF: 5.6kips * (INCLUDES IMPACT)
*R1	*R2	FOR TOTAL PULL-OUT FORCE ON RAIL BRACKET, R1 MUST BE DOUBLED eg.
304lb.f.	194lb.f.	
RAIL WEIGHT : 8.0 lbs / ft		

RAIL BRACKET

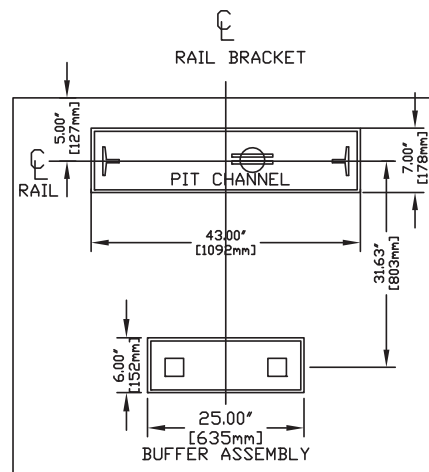

Plan view – Infinity type 2 with bi-fold doors (36" cab width)

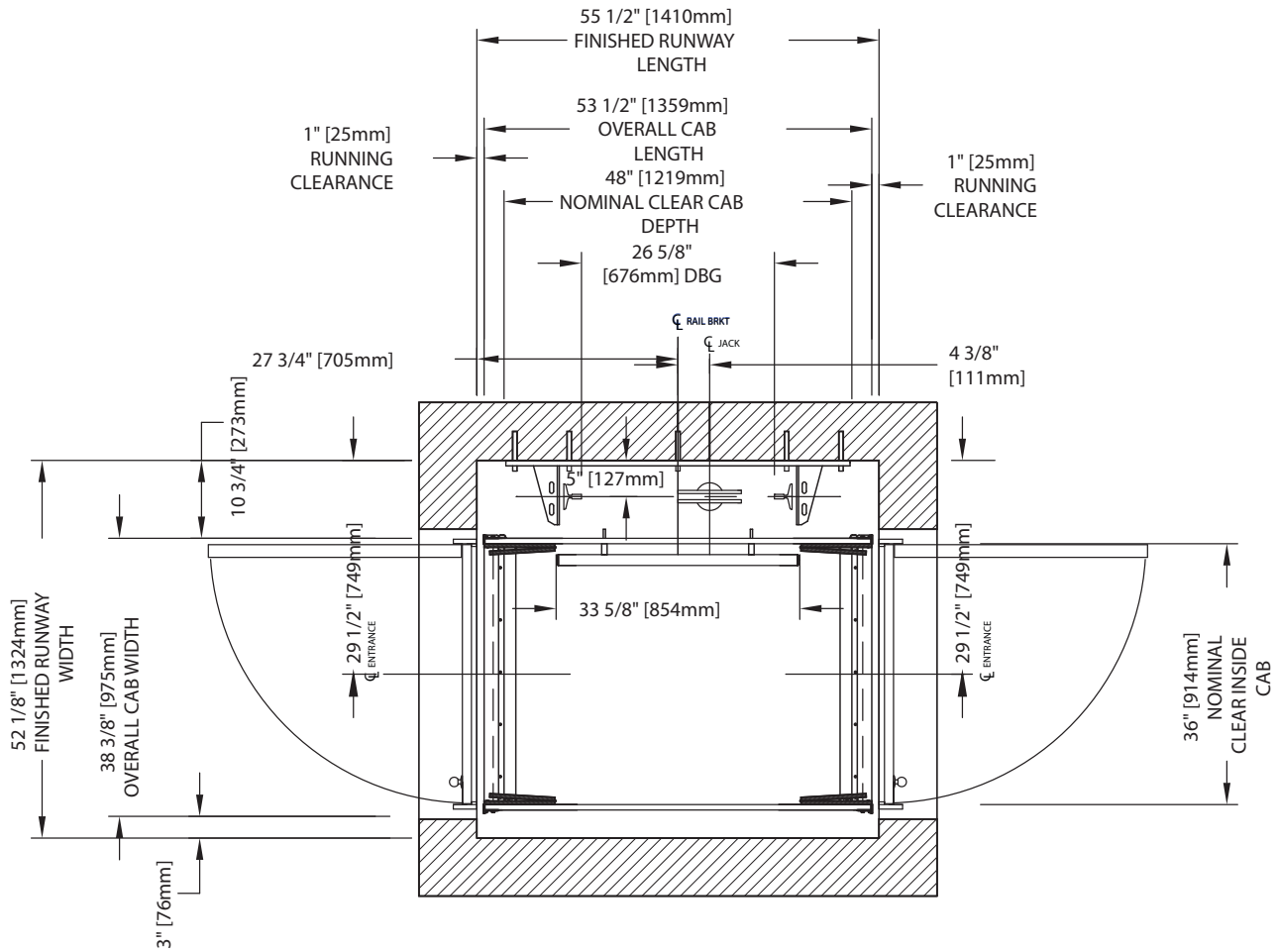

NOMINAL CLEAR INSIDE CAB WIDTH		NOMINAL CLEAR INSIDE CAB LENGTH		A FINISHED RUNWAY WIDTH		B FINISHED RUNWAY LENGTH		C RAIL CENTRE LINE		D DOOR CENTER LINE	
mm	inches	mm		mm	inches	mm	inches	mm	inches	mm	inches
914	36	1219	48	1308	51 1/2	1410	55 1/2	705	27 3/4	743	29 1/4
914	36	1372	54	1308	51 1/2	1562	61 1/2	781	30 3/4	743	29 1/4
914	36	1499	59	1308	51 1/2	1689	66 1/2	845	33 1/4	743	29 1/4

Plan view – Infinity type 2 with bi-fold doors (40" cab width)

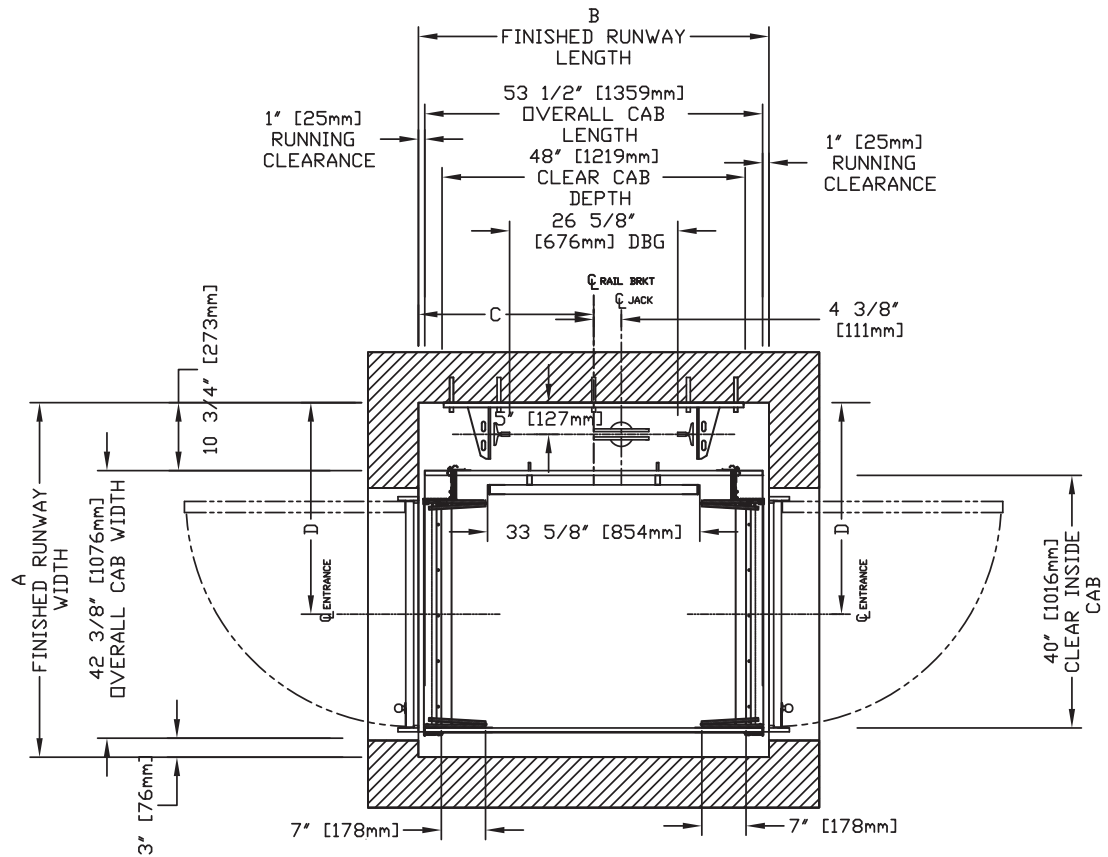

CLEAR INSIDE CAB WIDTH		CLEAR INSIDE CAB LENGTH		A FINISHED RUNWAY WIDTH		B FINISHED RUNWAY LENGTH		C RAIL CENTER LINE		D DOOR CENTER LINE	
mm	Inches	mm	Inches	mm	Inches	mm	Inches	mm	Inches	mm	Inches
1016	40	1219	48	1426	56 1/8	1410	55 1/2	705	27 3/4	851	33 1/2
1016	40	1372	54	1426	56 1/8	1562	61 1/2	781	30 3/4	851	33 1/2
1016	40	1524	60	1426	56 1/8	1715	67 1/2	857	33 3/4	851	33 1/2

Find more design resources at:

savaria.com

[Online configurator](#)

[CAD drawings](#)

[BIM objects](#)

[SpecWizard](#)

[Continuing education calendar](#)

Savaria Concord Lifts, Inc.
2 Walker Drive Brampton ON L6T 5E1 Canada

 **savaria.**
savaria.com

©2025 Savaria Corporation