



Omega
Curved Inclined
Platform Lift

Planning
Guide

 savaria.

Applicable Codes:

ASME A17.1

ASME A18.1

CAN/CSA B355

CAN/CSA B613

Copyright © 2023
Savaria Concord Lifts, Inc.
All rights reserved.

Printed in Canada

Purpose of This Guide

This guide assists architects, contractors, and lift professionals to incorporate the OMEGA Inclined Platform Lift into a residential or public building design.

The design and manufacture of the OMEGA Inclined Platform Lift meets the requirements of the following codes and standards:

- ASME A18.1-2003 Section 3 (Public)
- ASME A18.1-2005 Section 3 (Public)
- ASME A18.1-2008 Section 3 (Public)
- ASME A18.1-2011 Section 3 (Public)
- ASME A18.1-2014 Section 3 (Public)
- ASME A18.1-2017 Section 3 (Public)
- ASME A18.1-2003 Section 6 (Private)
- ASME A18.1-2005 Section 6 (Private)
- ASME A18.1-2008 Section 6 (Private)
- ASME A18.1-2011 Section 6 (Private)
- ASME A18.1-2014 Section 6 (Private)
- ASME A18.1-2017 Section 6 (Private)
- ASME A17.1-1996 Section 20 (Public)
- ASME A17.1-1996 Section 21 (Private)
- CAN/CSA B355 S1-02 (Public)
- CAN/CSA-B355-09 (Public)
- CAN/CSA B613-2000 (Private)

We recommend that you contact your local authority having jurisdiction to ensure that you adhere to all local rules, regulations and fire regulations pertaining to inclined platform lifts.

IMPORTANT: This Planning Guide provides nominal dimensions and specifications useful for the initial planning of an inclined platform lift project. **Dimensions and specifications are subject to change without notice due to continually evolving code and product applications.**

Before beginning actual construction, please consult Savaria or the authorized Savaria dealer in your area to ensure you receive your site-specific installation drawings with the dimensions and specifications for your project.

Visit our website for the most recent drawings and dimensions.

How to Use This Guide

- 1 Determine your client's intended use of the lift.
- 2 Determine the local code requirements.
- 3 Determine the site installation parameters.
- 4 Plan for electrical requirements.

History

February 6, 2012 – Initial release

February 14, 2012 – Corrected codes above

April 24, 2012 – Various updates throughout

June 28, 2012 – Revised pages 21, 22 and 23

September 5, 2012 – Added note regarding extra grabrail option to specifications table on page 6 and added note to drawings on pages 18 and 20 regarding 1" space requirement for folding/unfolding in tight spaces

December 13, 2012 – Revised speed and added minimum travel in specifications table on page 6; Added support load diagram on page 16

January 10, 2013 - Revised NOTE on pages 18 and 20, revised tables on pages 21, 22 and 23

July 8, 2013 - Added Noise Level to specifications table on page 6

July 10, 2013 - Revised tables on page 21

May 13, 2014 - Revised drawing on page 21

May 14, 2014 - Revised text to indicate manual folding seat on pages 5, 6, and 7

July 31, 2014 - Revised Maximum Load in Specifications table on page 6

November 5, 2014 - Revised Applicable Codes on page 3

January 20, 2015 - Added new 2014 code in section above

April 27, 2015 - Added note re: installation distance of controller from motor (pg. 8 and 25)

May 25, 2015 - Revised sample installation wiring layout diagram on page 29

September 24, 2015 - Added Daily Cycle to specifications table on page 6

March 7, 2016 - Removed copyright from cover page; Savaria Corporation back to Savaria Concord Lifts, Inc.

March 30, 2016 - Various revisions throughout

April 29, 2016 - Revised tables on page 23

January 17, 2017 - Added note re: buck-boost transformer to specs table on page 6

February 16, 2017 - Revised temperature spec in specs table on page 6

March 7, 2017 - Added Imperial equivalent measurements throughout

March 20, 2017 - Added minimum parking clearance (F) to tables on pages 24 and 25

May 11, 2018 - Revised power supply spec on pages 6 and 17

September 27, 2018 - Added ASME 18.1-2017 to list of codes on this page

November 1, 2018 - Added important note on page 16 re: installation of infill panels/barrier

February 3, 2020 - Removed "negative curve dimensions - 2" from page 28

August 2 2022 - Updated cover

May 29, 2023 - Added Options to page 7

Contents

Description of the lift	5
Features and benefits	5
Specifications of the lift	6
Lift components	7
Standard drive unit with remote controller box (top landing)	8
Optional drive/controller cabinet (top landing)	8
Overspeed governor (bottom landing)	8
Lift controls	9
Buck-boost transformer (optional)	10
Guide rails	11
Guide rail mounting	12
Optional handrail (sample drawing)	13
How the system works	14
Features	15
Obstruction sensors	15
Safety arms and platform ramps	15
Limit switches	15
Emergency stop button	15
On-board alarm button	15
Platform key switch	15
Landing light	15
Overspeed governor (safety brake)	15
Manual lowering device	15
Site verification	16
Stairway	16
Minimum overhead clearance	16
Construction site	16
Dimensions	16
Installation	16
Provisions by others	16
Electrical requirements	17
General	17
Main power supply	17
Lighting	17
Structural requirements	18
Floor/support wall loads	18
Support load diagram	18
Platform – 775 x 1250 mm (30.5 x 49.25"), sheet 1	19
Platform – 775 x 1250 mm (30.5 x 49.25"), sheet 2	20
Platform – 720 x 900 mm (28.3 x 35.4"), sheet 1	21
Platform – 720 x 900 mm (28.3 x 35.4"), sheet 2	22
Lower level clearances	23
Turning clearances (90 degree curve)	24
Turning clearances (180 degree curve)	25
Steep start	26
Negative curve dimensions	27
Standard drive unit clearances	28
Remote controller box dimensions	29
Landing light box dimensions	29
Optional drive/controller cabinet dimensions (sheet 1)	30
Optional drive/controller cabinet dimensions (sheet 2)	31
Call station dimensions	32
UPS dimensions	33
Sample installation wiring layout	34

Description of the lift

The OMEGA Inclined Platform Lift is an accessibility device used to provide access over multiple levels of straight stairs, stairs with intermediate landings, or stairs with turns.

The lift will transport a passenger either sitting in a wheelchair or on the manual folding seat.

The unit travels along the guide rails at a comfortable speed up to 14 feet per minute (0.07 metres per second).

The unit is driven by a rope traction drive system. The standard drive unit is mounted on the rail at the top of the stairs for rail lengths under 20 metres (65.6 feet) or in an optional drive cabinet for rail lengths over 20 metres (65.6 feet).

The OMEGA is easy to operate using the on-board pendant control. When the lift is not in use, it can be parked and folded up allowing access to the stairs.

The OMEGA is suitable for either indoor or outdoor use, and can be factory-built for left- or right-side rail installations.

Features and benefits

- Major building renovations are usually not required as the OMEGA is installed on a modular guide rail system that follows along an existing stairway. The rails will be securely fastened to a supporting wall, the stairs, or both.
- The space-saving design of the platform and the rail system allows the platform to fit into narrow staircases.
- The lift can be parked at the top or bottom of the staircase.
- A tight turning radius is possible.
- Inside or outside curve installations are accommodated.
- The lift platform is ADA-compliant.
- A compact standard drive is installed at the top of the rail system. An optional larger drive cabinet can be used for longer runs over 20 metres (65.6 feet).
- The rope traction drive system allows for longer installation runs.
- A robust platform motor operates folding and unfolding of the platform, arms and ramps.

Specifications of the lift

Specification	Data
Maximum load	550 lb (250 kg) in Canada 660 lb (300 kg) in USA
Gradient	45° - Public 55° - Residential
Capacity	One person in wheelchair or sitting on manual folding seat; seat capacity is 330 lb (150 kg)
Platform sizes	49.2" x 30.5" (1250 mm x 775 mm) 35.4" x 28.3" (900 mm x 720 mm) Custom platform sizes
Travel speed	12 feet/minute (0.06 metres/second)
Maximum travel	164 ft (50 m)
Minimum travel	8 in (20 cm)
Temperature	-4 °F to +113 °F (-20 °C to +45 °C) NOTE: <i>It is important to keep the inside of the upper tube free of ice to ensure proper contact to the current collector.</i>
Noise level (for typical installation)	61.5 dBA (up direction); 60.8 dBA (down direction) Measured at a height of 1m, distance of 1m, in front of the motor with all panels on
Power supply	240 VAC (+/-5%), 15 Amps (20 Amps for Omega Max model) NOTE: <i>If not stable at 230V minimum, a buck-boost transformer is required to bring the voltage up to 240V.</i>
Motor	1 hp (0.75 kW) 3 hp (2.2 kW over 30 m)
Daily cycle	Normal: 10 Heavy: 30 Excessive: 50 Maximum starts in 1 hour on standard installation: 5 NOTE: <i>Please consult your Sales Representative if there a chance you may exceed these amounts.</i>
Pendant control buttons	Two constant-pressure directional buttons to move the lift up or down the stairway and an emergency STOP button to stop the lift in an emergency
Remote call station buttons	Used to call/send the lift and fold/unfold the platform (call send only works with platform folded up)
Platform control panel	Emergency STOP button to bring the lift to an immediate stop Audible alarm button to signal for help Key switch to enable use of the pendant control buttons
Standard features	Pendant control buttons (on platform) Constant-pressure type buttons Manual lowering capability (using handwheel) Safety arms Limit switches No machine room required Emergency stop button Audio visual alarm (running buzzer and light) to indicate the unit is in use Manual folding seat (with seat belt)
Safety features	Edge sensors Underpan sensors Safety brake Safety arms Platform ramps Emergency stop button Limit switches Manual operation (using handwheel)
Options	Outdoor package (requires outdoor rail) Key switch for call station Extra grabrail 90-degree ramp NOTE: <i>For the extra grabrail option to meet local code requirements, please confirm with the factory if it is feasible depending on the stair angle and platform size before final approval.</i>
Color	Light grey (RAL 7035), Custom color (any RAL color) Outdoor: Light grey lift, galvanized rails

Specification	Data
Options	Exterior package (For outdoor applications, consult your local Savaria dealer as not all climates may be suitable for outdoor installations)

Lift components

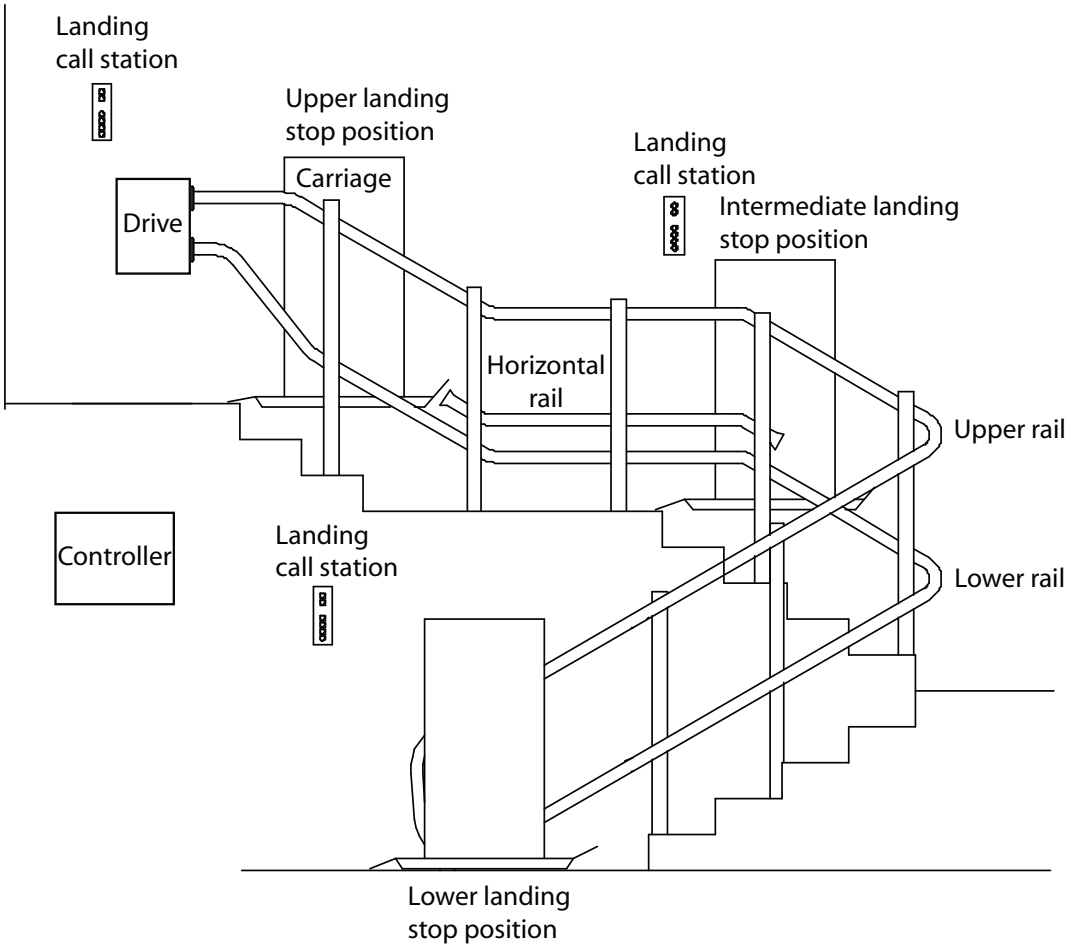

Standard drive unit with remote controller box (top landing)

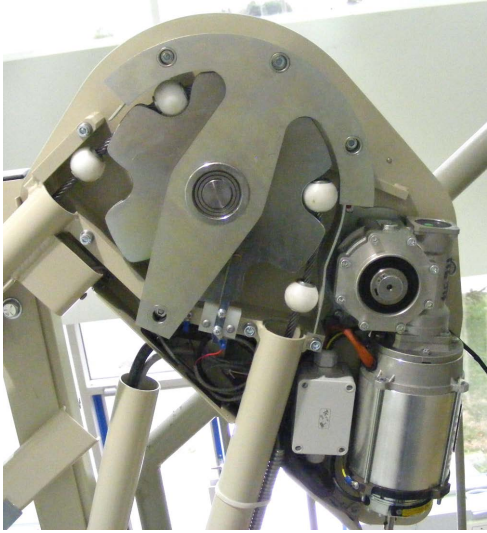

NOTE: It is recommended that the controller be installed a maximum distance of 30 feet (9.1 metres) from the motor.

Optional drive/controller cabinet (top landing)

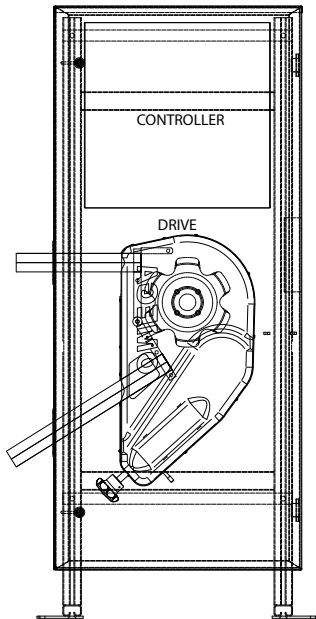

OTHER OPTION



Overspeed governor (bottom landing)

The overspeed governor is a safety device located at the lower end of the rail. It consists of an electrical switch and a mechanical device that activate together to stop the platform from moving if it is descending down the stairs too quickly.



Lift controls



The on-board, hand-held pendant has constant-pressure **UP/DOWN** buttons allowing you to move the platform up or down the stairway. There is also a red emergency **STOP** button.

PLATFORM PENDANT

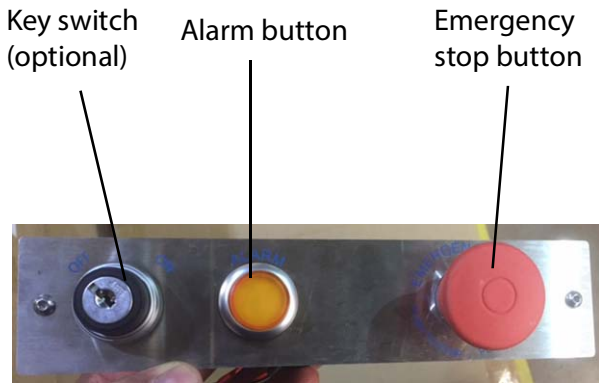

Key switch – use to activate/deactivate the platform pendant controls
Alarm button (if equipped) – use in an emergency to sound an audible alarm
Emergency STOP button – use in an emergency to stop the lift

PLATFORM CONTROL PANEL



UP

DOWN

FOLD

UNFOLD

KEY SWITCH (OPTIONAL)

UP/DOWN buttons – use to call the lift to the required landing

FOLD/UNFOLD buttons – use to fold or unfold the platform and raise or lower the ramps

KEY SWITCH (optional) – use to activate/deactivate the call station controls

CALL STATION

Guide rails

The lift travels up and down the stairway along two guide rails – an upper rail and a lower rail. The mounting location of the rails depends on the platform size and the angle of the stairs.

If the angle of the stairs is less than 20 degrees, a third rail (horizontal stabilizer rail) is required to stabilize the platform. Horizontal rail sections may be required at half-landings or stop positions. A sample horizontal rail installation is shown below.

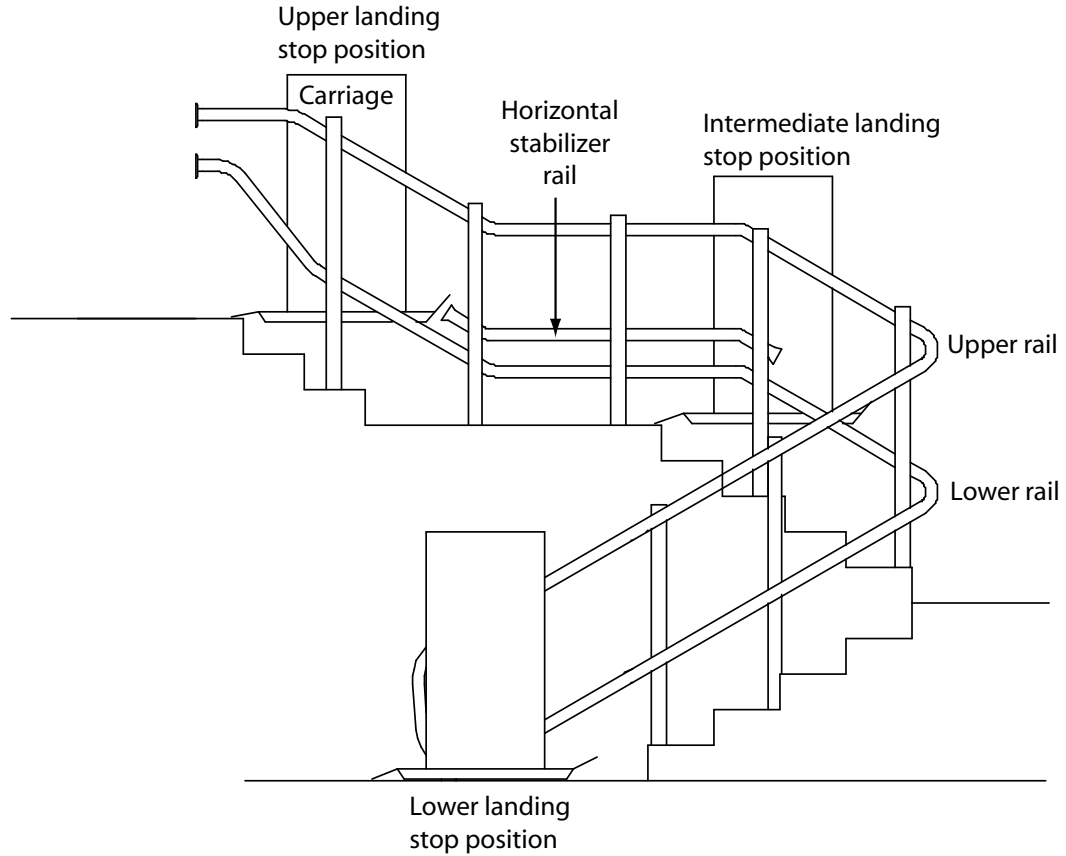

Galvanized rail for outdoor applications (shown below)



Guide rail mounting

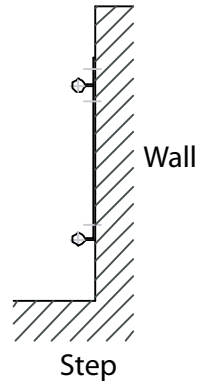

WALL MOUNTED

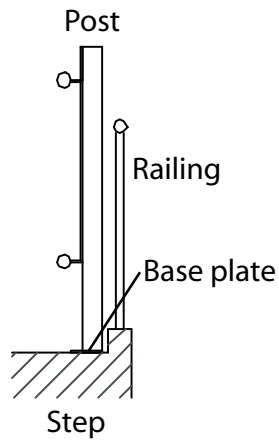

POST MOUNTED ON STEPS

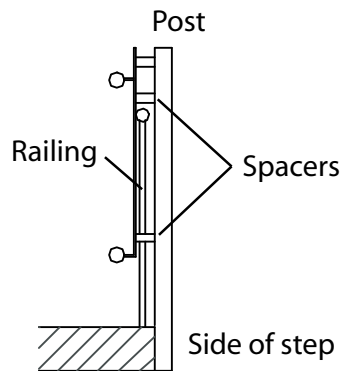

POST MOUNTED ON SIDE OF STAIRS

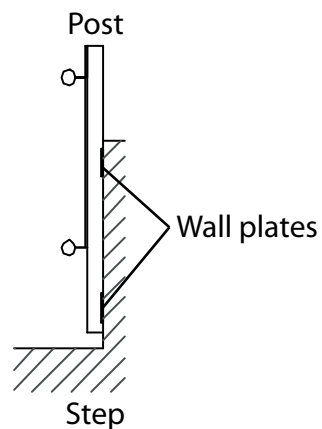

POST MOUNTED TO WALL

Optional handrail (sample drawing)

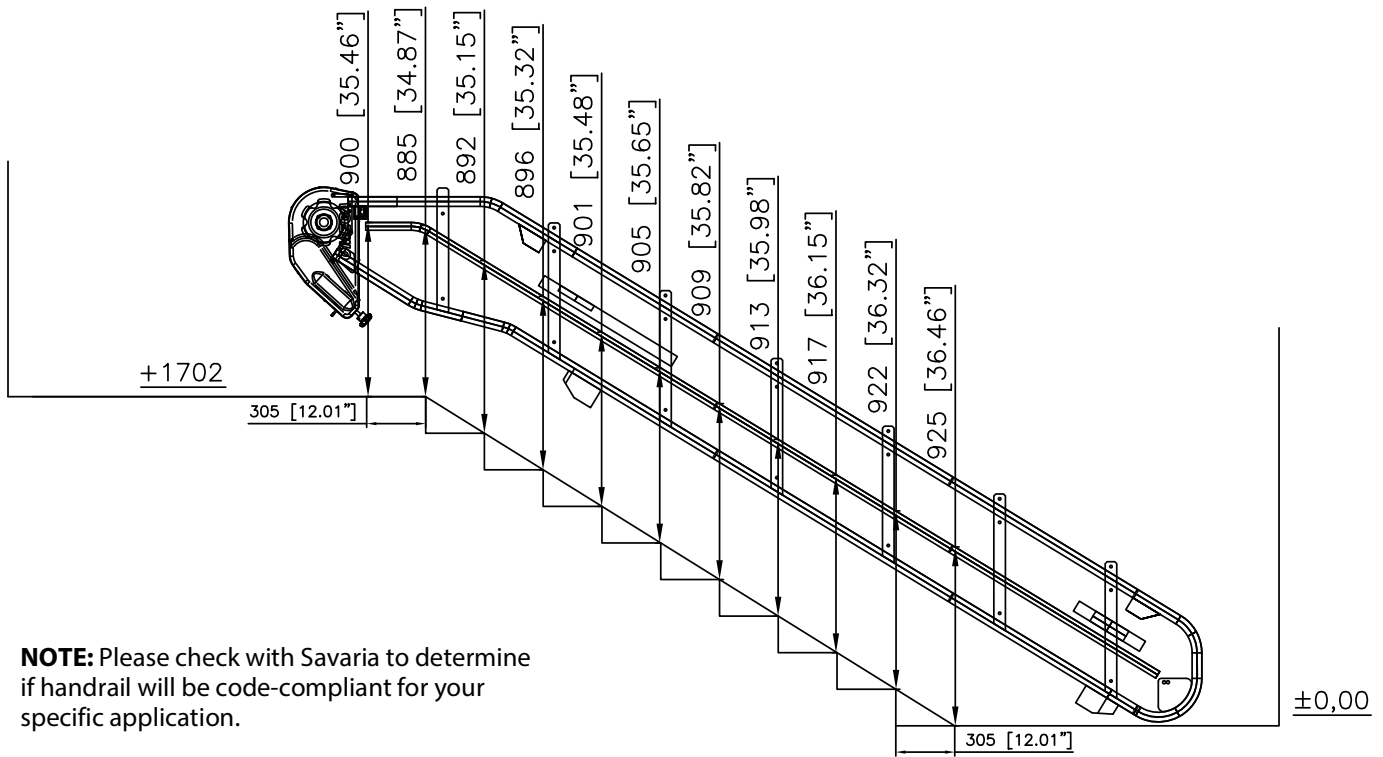

NOTE: Please check with Savaria to determine if handrail will be code-compliant for your specific application.

How the system works

The Omega carriage/platform assembly travels along a guide rail system that is custom designed for each site. This railway consists of an upper tube and a lower tube that houses a continuous loop of rope. The drive system moves the carriage/platform assembly up and down the stairs by means of this rope.

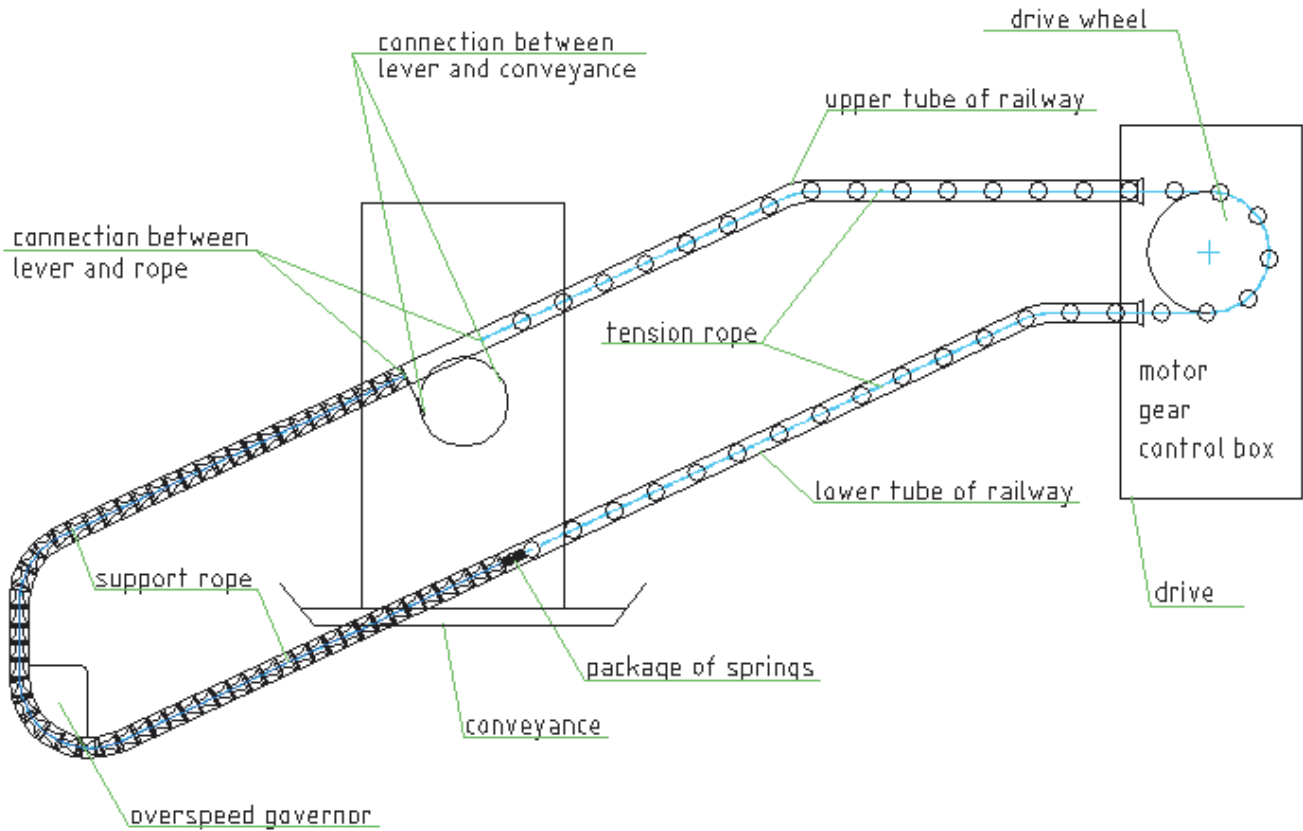

Features

Obstruction sensors

During travel, the edges of the platform ramp and the carriage of the lift are protected by sensors which stop the lift if it touches an obstacle.

There are also safety underpan sensors to detect an obstacle underneath the platform and carriage and stop the lift.

Safety arms and platform ramps

While in motion, the platform is protected by two safety arms. The platform is also protected by two side access ramps (and an optional front access ramp) which have the dual function of facilitating access to the lift at the floors (open position) and of retaining the wheelchair while the lift is in motion (safety position).

Before the lift leaves the floor, the safety arms must be down and the platform ramps must be up.

If the underpan or platform ramps encounter an obstacle as they move into position, a microswitch is tripped, stopping the lift. You can drive away from the obstacle in the other direction in order to remove the obstacle.

Limit switches

The upper and lower limit switches allow the lift to stop automatically in the correct landing position at the upper or lower end of the staircase. If the upper or lower limit switch fails, the additional final safety limit switch stops the unit.

Emergency stop button

There is a red emergency STOP button located on the platform control panel and on the handheld pendant which can be pressed in an emergency to stop the lift.

On-board alarm button

The yellow alarm button is located on the platform control panel and can be pressed in an emergency to sound an audible alarm indicating that assistance is required.

Platform key switch

The key switch is located on the platform control panel and is used to activate/de-activate the platform pendant controls.

Landing light

The yellow landing light is mounted in view of each landing and the travel of the lift, either at the middle landing or in the middle of travel. The landing light flashes to indicate that the unit is in use.

Overspeed governor (safety brake)

The overspeed governor is a safety device located at the lower end of the rail. It will activate to quickly bring the lift to a stop if it is descending down the stairs too quickly.

Manual lowering device

You can use the manual handwheel by inserting it on the motor shaft to bring the lift to the next landing in the event of an emergency. You can also use an electric drill with the provided adapter for faster lowering.

Site verification

Stairway

Due to close running clearances, the Owner/Agent must ensure that the stairs (where provided) are level, plumb (+/-1/8" (3 mm)) and square and are in accordance with the dimensions specified on the site-specific plan drawings.

Minimum overhead clearance

The Owner/Agent must ensure the minimum overhead clearance is in compliance with codes.

Construction site

The Owner/Agent is responsible for all masonry, carpentry and drywall work as required, and for patching and finishing (including painting) all areas where walls/floors may need to be cut, drilled or altered in any way to permit the proper installation of the lift.

Dimensions

The Contractor/Customer must verify all dimensions on the site-specific plan drawings and report any discrepancies to the Agent or Distributor.

Installation

The equipment must be installed by a qualified technician in compliance with the codes identified on the front cover of this manual.

The conformity for access to the platform is the distributor's responsibility.

Provisions by others

IMPORTANT NOTE

Upon completion of installation when the back of the rail is exposed, infill panels must be installed between the support posts, or a constructed barrier or wall must be installed behind the rail (see the illustration below). This will prevent access to the back of the rail during operation.

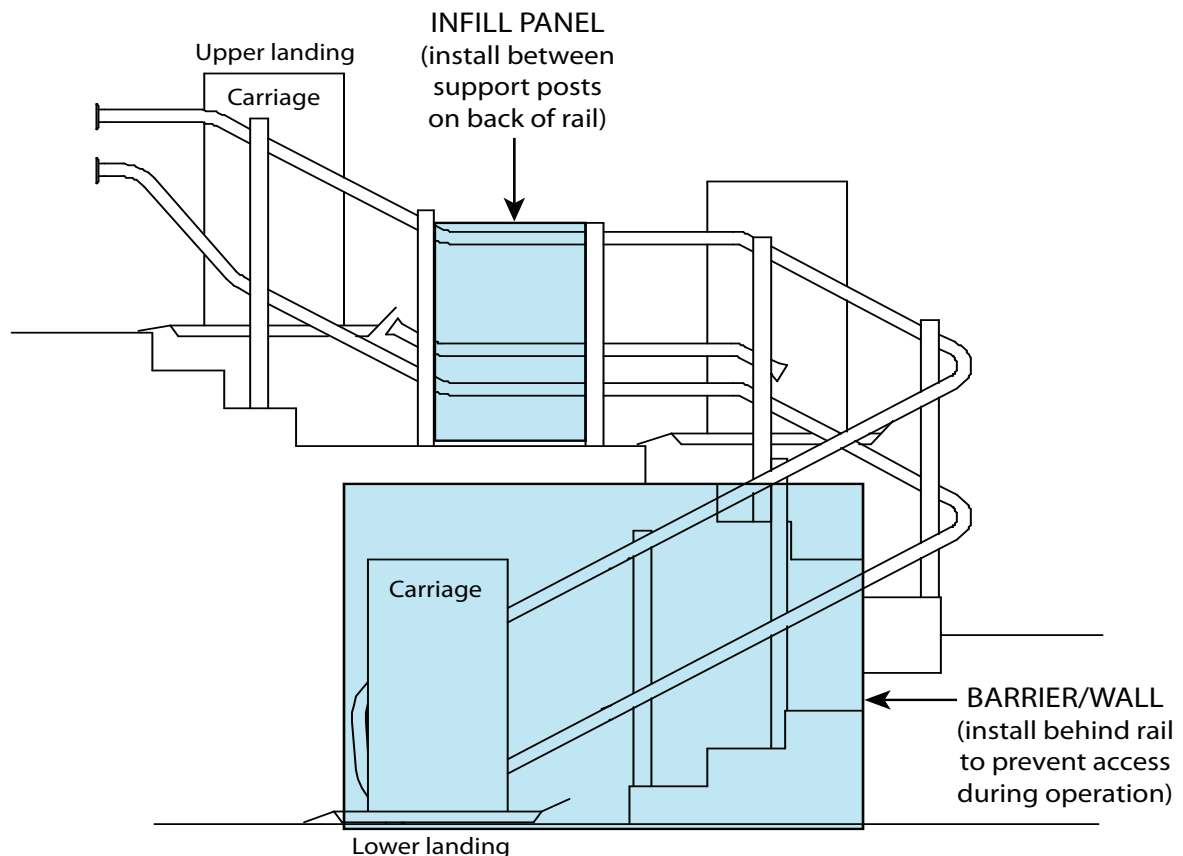

Electrical requirements

General

Electrical equipment and wiring must comply with Section 38 of CSA C22.1 (Canada) or Section 620 of NEC ANSI/NFPA 70 (USA).

Main power supply

240 VAC (+/-5%), single-phase, 60 Hz, on a dedicated 15 amp circuit for 0.75 kW motor (20 amp circuit for 2.2 kW motor) through a fused disconnect. The disconnect should be installed close to the controller, if possible.

Contractor/customer to provide two 14 AWG conductors plus GND conductor between the fused disconnect contact and the power supply box.

Lighting

Contractor/customer to provide lighting. Lighting must be a minimum of 100 Lux at the platform and landings, and must have a switch and electrical GFCI outlet.

Contractor/customer to provide emergency lighting. Emergency lighting of 2 Lux must be provided for a minimum of one hour on the platform along the travel route.

Structural requirements

Floor/support wall loads

A qualified professional must ensure that the building and stairway will safely support all loads imposed by the lift equipment. Adequate structural support must be provided at the top landing, bottom landing and throughout the supporting wall along the stairs.

The pull-out force on the supporting wall will vary depending on the type of rail mounting used (wall brackets or support). Refer to the previous illustration of the guide rail mounting configurations.

All wood studs in the supporting wall must be anchored in the ceiling and the floor to meet the pull-out force requirements. Wood studs must be placed at 16" (404 mm) centres (minimum), solidly anchored in the floor and ceiling.

The floor load will vary depending on the type of rail mounting used (wall brackets or support posts on the steps).

Where required, the rail must be securely fastened to the structural support wall.

Support load diagram

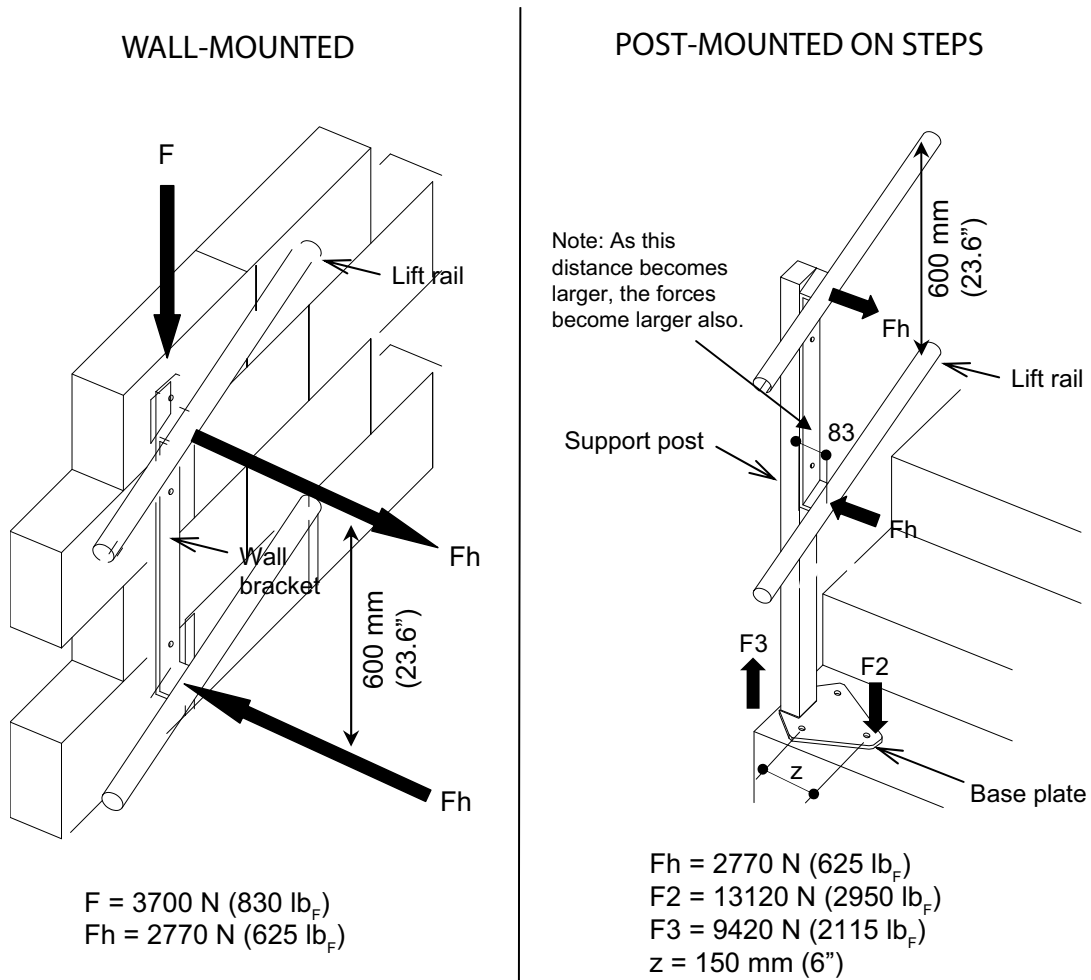

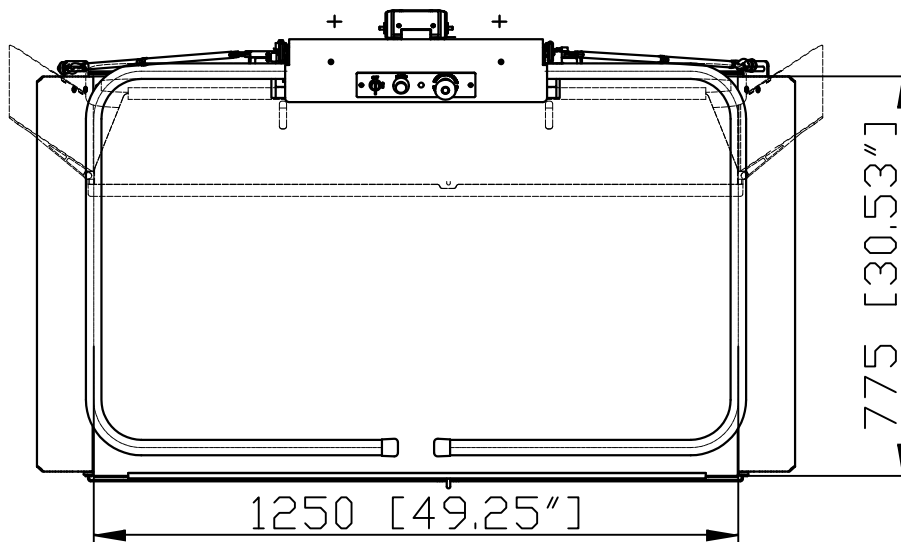
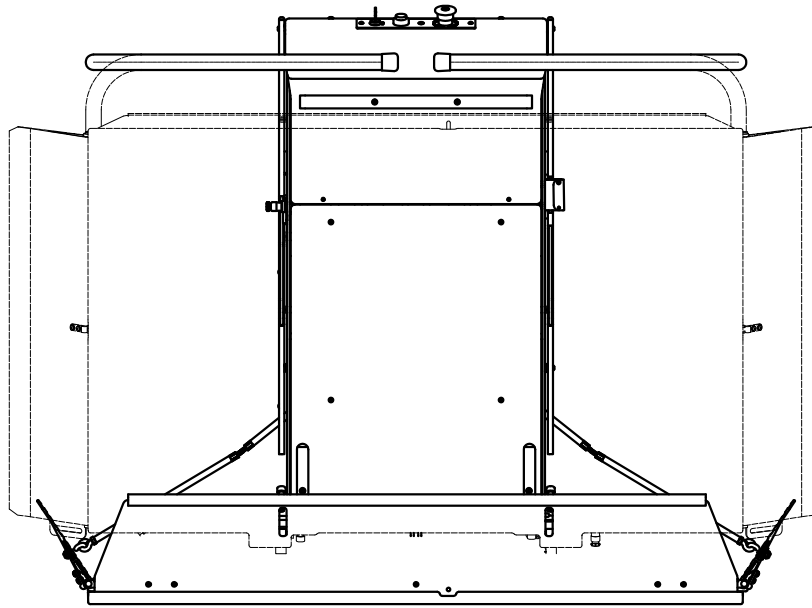
Platform – 775 x 1250 mm (30.5 x 49.25"), sheet 1

PLF_OMEGA (775X1250)
STRAIGHT ENTRANCE

Platform – 775 x 1250 mm (30.5 x 49.25"), sheet 2

INLINE ACCESS PLATFORM 775 x 1250 (30.5" x 49.21")

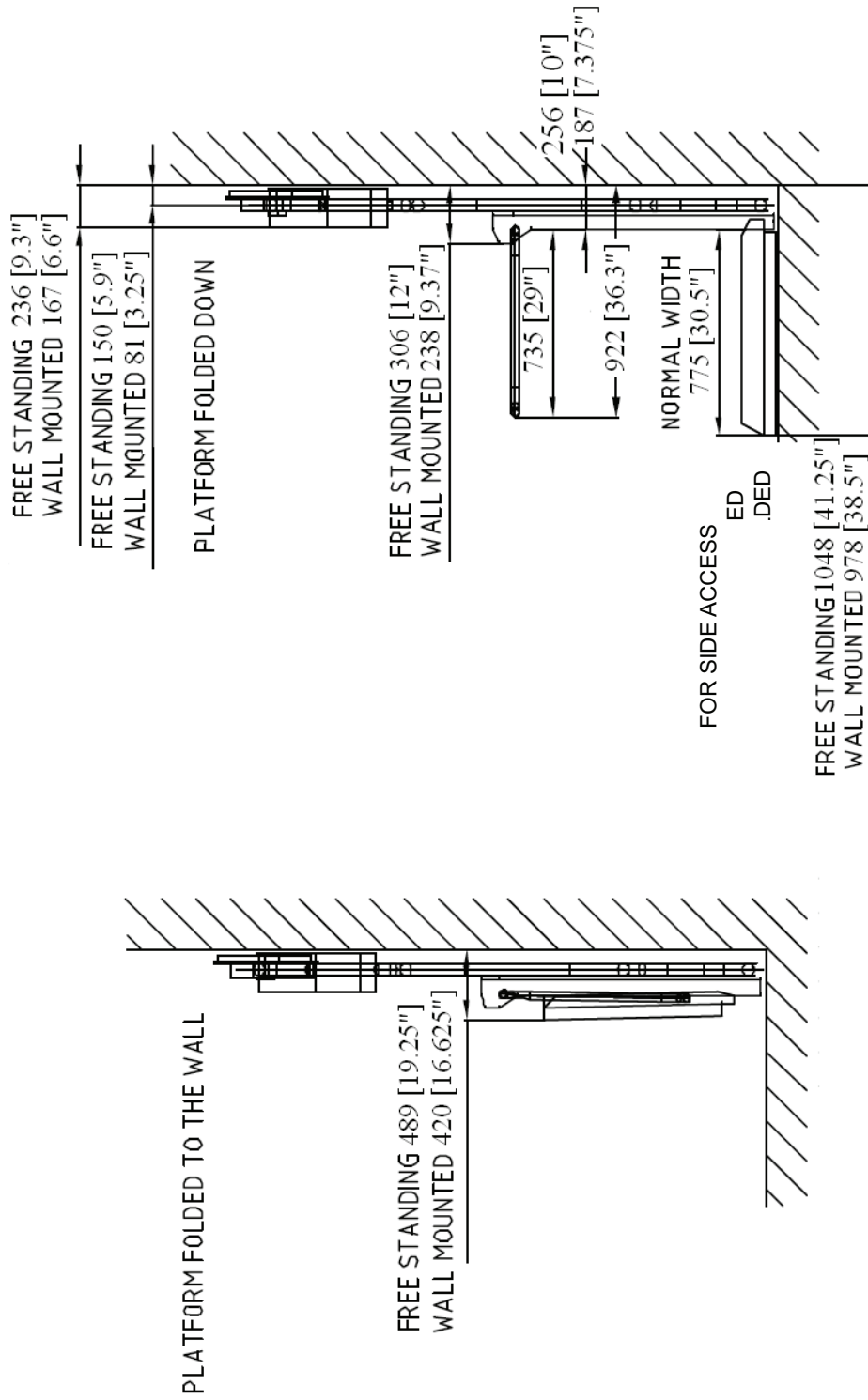

NOTES: An extra 1" (25.4 mm) of width is required to fold/unfold the platform in tight areas.
 Post-mounted units need 3.5" (89 mm) more width.

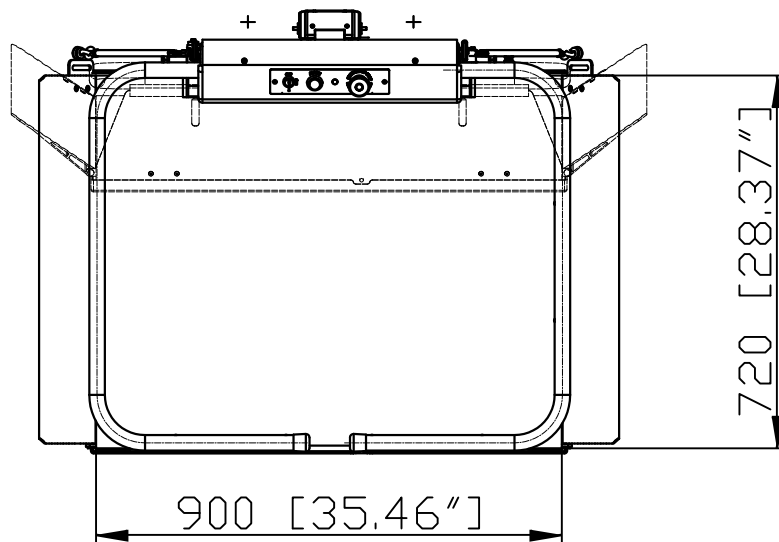
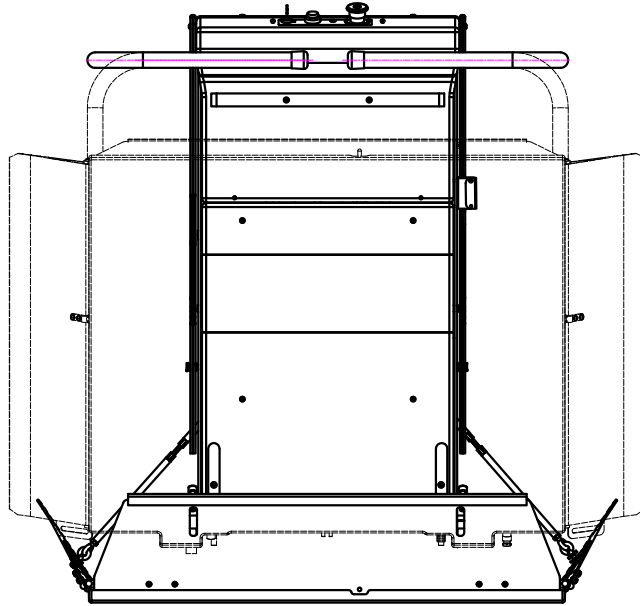
Platform – 720 x 900 mm (28.3 x 35.4"), sheet 1

PLF_OMEGA (720X900)
STRAIGHT ENTRANCE

Platform – 720 x 900 mm (28.3 x 35.4"), sheet 2

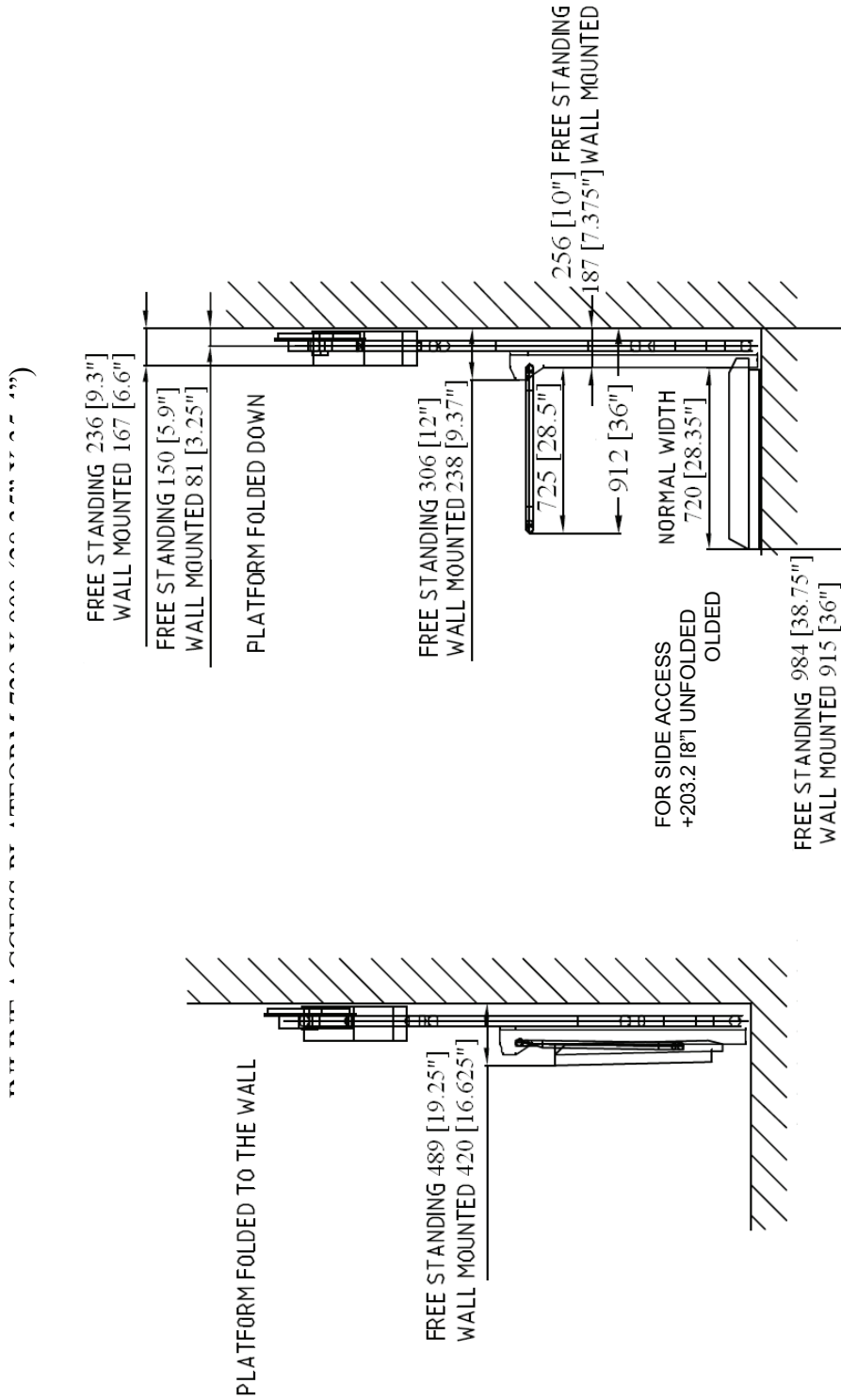

NOTES: An extra 1" (25.4 mm) of width is required to fold/unfold the platform in tight areas. Post-mounted units need 3.5" (89 mm) more width.

Lower level clearances

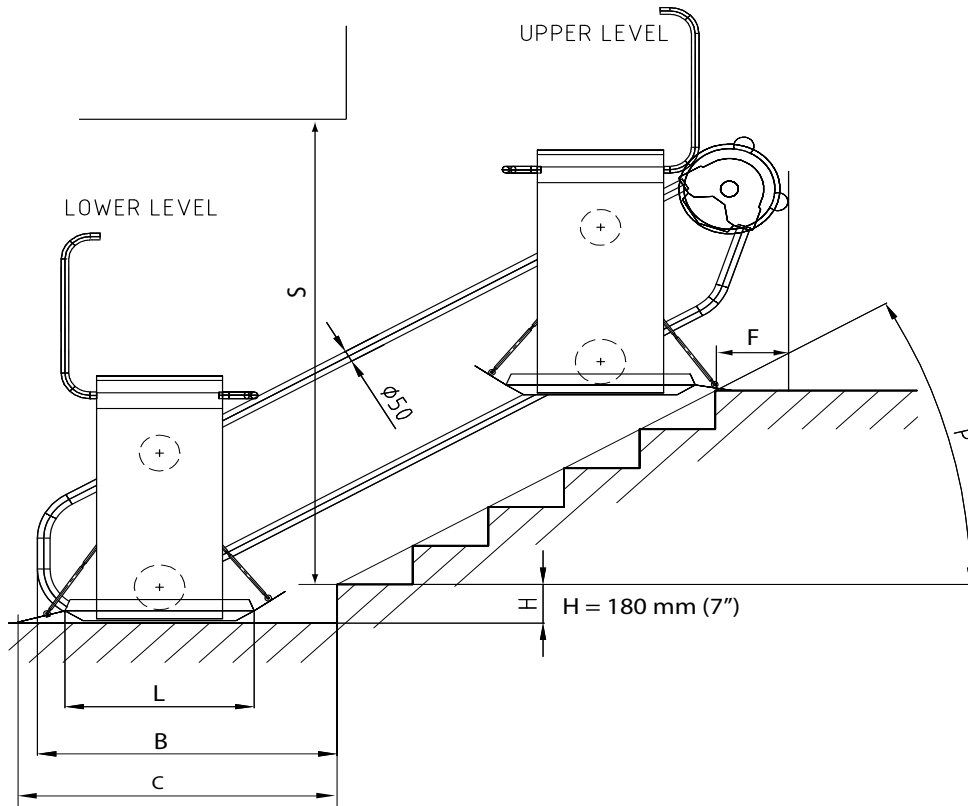

Refer to the charts below for clearance values.

NOTE: The values in the charts could change due to site conditions.

LEGEND

- L = Platform length
- B = End of rail at bottom landing
- C = End of platform at bottom landing
- F = Top rail distance at top landing
- P = Angle
- S = Overhead minimum (see local code for details/restrictions)

L =	1250	49.3					US CODE		CANADA CODE	
ANGLE (P)	b (mm)	b (inch)	*c (mm)	*c (inch)	f (mm)	f (inch)	S (mm)	S (inch)	S (mm)	S (inch)
15°	1625	64	2147	85	33	2	1960.6	78	1778	70
20°	1565	62	1974	78	40	2	2084.4	83	1841	72.5
25°	1505	60	1880	75	-75	-3	2214.6	88	1898	75
30°	1449	58	1815	72	-73	-3	2355.9	93	1971	78
35°	1378	55	1768	70	-73	-3	2514.6	99	2054	81
40°	1318	52	1731	69	-73	-3	2692.4	106	2203	87
45°	1276	51	1701	67	-73	-3	2899	115	2438	96

L =	900	35.5					US CODE		CANADA CODE	
ANGLE (P)	b (mm)	b (inch)	*c (mm)	*c (inch)	f (mm)	f (inch)	S (mm)	S (inch)	S (mm)	S (inch)
15°	1500	60	1797	71	190	8	1870	74	1721	68
20°	1400	56	1624	64	190	8	1959	78	1772	70
25°	1330	53	1530	61	85	4	2052.6	81	1813	71.4
30°	1274	51	1465	58	85	4	2158	85	1866.9	73.5
35°	1203	48	1418	56	85	4	2272	90	1930	76
40°	1147	46	1381	55	85	4	2402	95	1997	79
45°	1111	44	1351	54	85	4	2553	101	2076	82

Turning clearances (90 degree curve)

90° CURVE

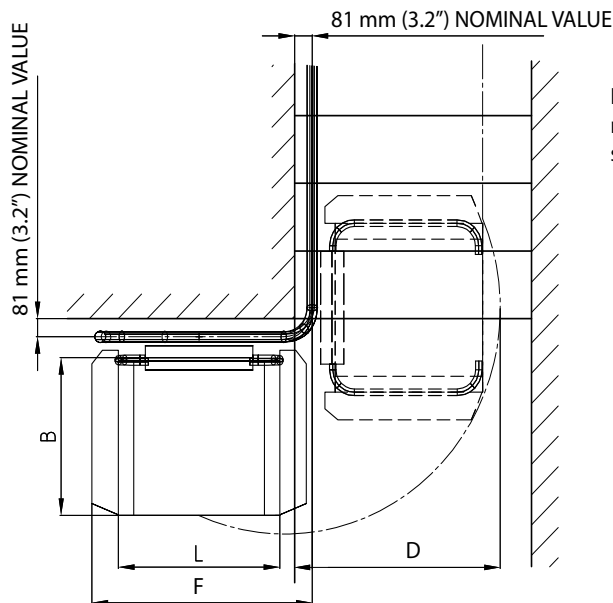
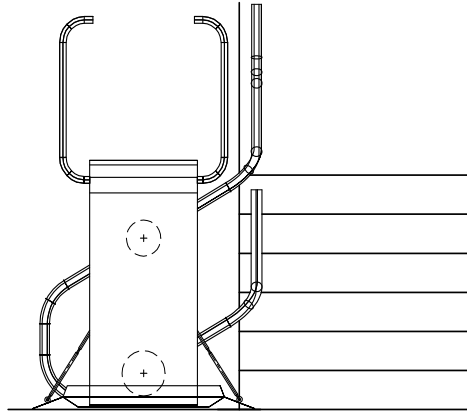

NOTE: Nominal values may change based on site conditions.

		PLATFORM WIDTH (B) X LENGTH (L)			
UNIT ACCESS/MOUNTING		720x900 mm (28.35"x35.5")	720x900 mm (28.35"x35.5")	775x1250 mm (30.5"x49.25")	775x1250 mm (30.5"x49.25")
INLINE ACCESS	ACCESS RAMPS	D (Std. Ramps)	D (Custom Ramps)	D (Std. Ramps)	D (Custom Ramps)
WALL MOUNTED	200 mm (8")	1067 (42")	1030 (40.5")	1207 (47.5")	1168 (46")
POST MOUNTED	200 mm (8")	1156 (45.5")	1118 (44")	1295 (51")	1257 (49.5")
90 DEGREE ACCESS					
WALL MOUNTED	200 mm (8")	1156 (45.5")	1092 (43")	1295 (51")	1232 (48.5")
POST MOUNTED	200 mm (8")	1245 (49")	1181 (46.5")	1384 (54.5")	1320 (52")
MINIMUM PARKING CLEARANCE (F)		1300 (51.5")	1300 (51.5")	1650 (65")	1650 (65")

NOTE: The running clearance is 19 mm (0.75") and is not included in the above calculations.

Turning clearances (180 degree curve)

180° CURVE

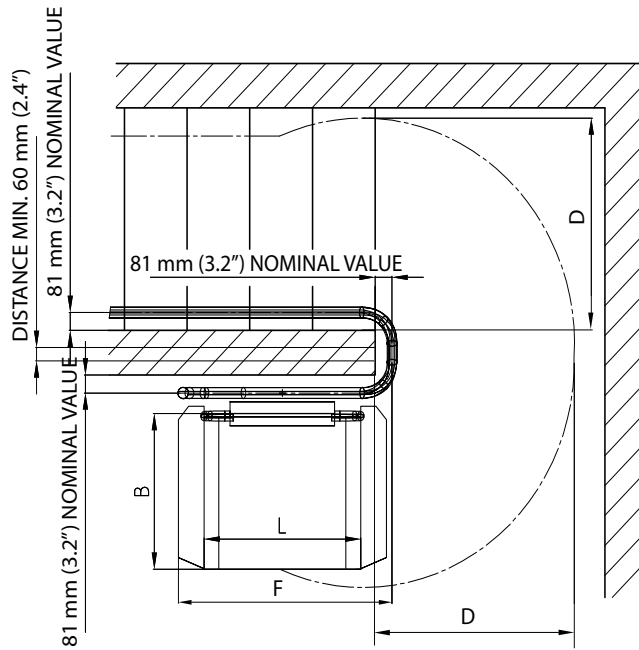
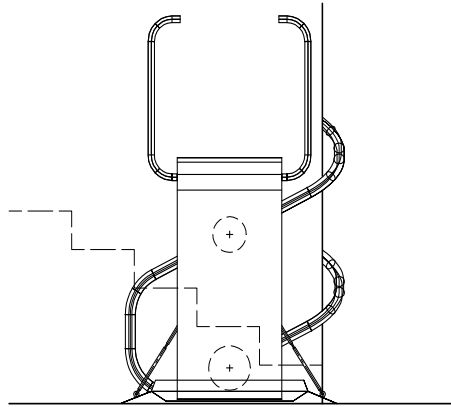

NOTE: Nominal values may change based on site conditions.

		PLATFORM WIDTH (B) X LENGTH (L)			
UNIT ACCESS/MOUNTING		720x900 mm (28.35"x35.5")	720x900 mm (28.35"x35.5")	775x1250 mm (30.5"x49.25")	775x1250 mm (30.5"x49.25")
INLINE ACCESS	ACCESS RAMPS	D (Std. Ramps)	D (Custom Ramps)	D (Std. Ramps)	D (Custom Ramps)
WALL MOUNTED	200 mm (8")	1067 (42")	1030 (40.5")	1207 (47.5")	1168 (46")
POST MOUNTED	200 mm (8")	1156 (45.5")	1118 (44")	1295 (51")	1257 (49.5")
90 DEGREE ACCESS					
WALL MOUNTED	200 mm (8")	1156 (45.5")	1092 (43")	1295 (51")	1232 (48.5")
POST MOUNTED	200 mm (8")	1245 (49")	1181 (46.5")	1384 (54.5")	1320 (52")
MINIMUM PARKING CLEARANCE (F)					
		1300 (51.5")	1300 (51.5")	1650 (65")	1650 (65")

NOTE: The running clearance is 19 mm (0.75") and is not included in the above calculations.

Steep start

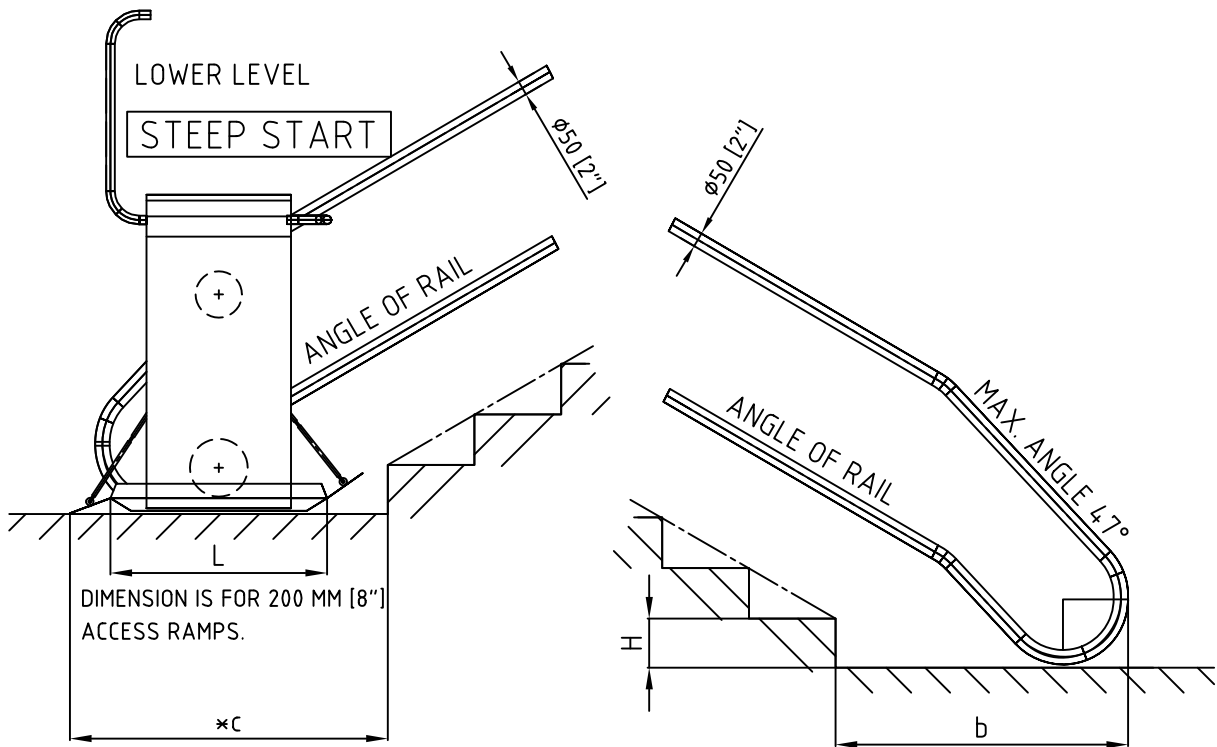
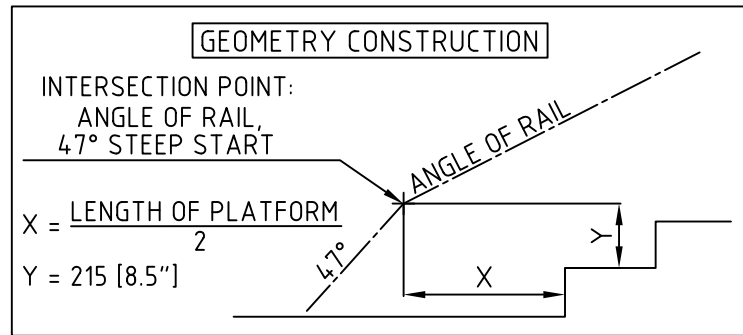

For Maximum Angle of 47 Degrees						
First Riser Height	L = 900 (35.5")		L = 1250 (49.25")		L = Special Size	
	H	b	c	b	c	b
150 (6")	1120 [44.25"]	1282 [50.5"]	1283 [50.5"]	1627 [64"]	0.5L + 670 [26.5"]	L + 382 [15"]
160 (6.3125")	1129 [44.5"]	1291 [51"]	1292 [51"]	1636 [64.5"]	0.5L + 679 [27"]	L + 391 [15.5"]
170 (6.75")	1138 [45"]	1300 [51.25"]	1302 [51.25"]	1646 [65"]	0.5L + 688 [27.25"]	L + 400 [15.75"]
180 (7.125")	1147 [45.25"]	1309 [51.5"]	1309 [51.5"]	1653 [65.25"]	0.5L + 697 [27.5"]	L + 409 [16.25"]
190 (7.5")	1156 [45.5"]	1318 [52"]	1318 [52"]	1662 [65.5"]	0.5L + 706 [28"]	L + 418 [16.5"]
200 (7.875")	1165 [46"]	1327 [52.25"]	1328 [52.5"]	1672 [66"]	0.5L + 715 [28.25"]	L + 427 [17"]

Negative curve dimensions

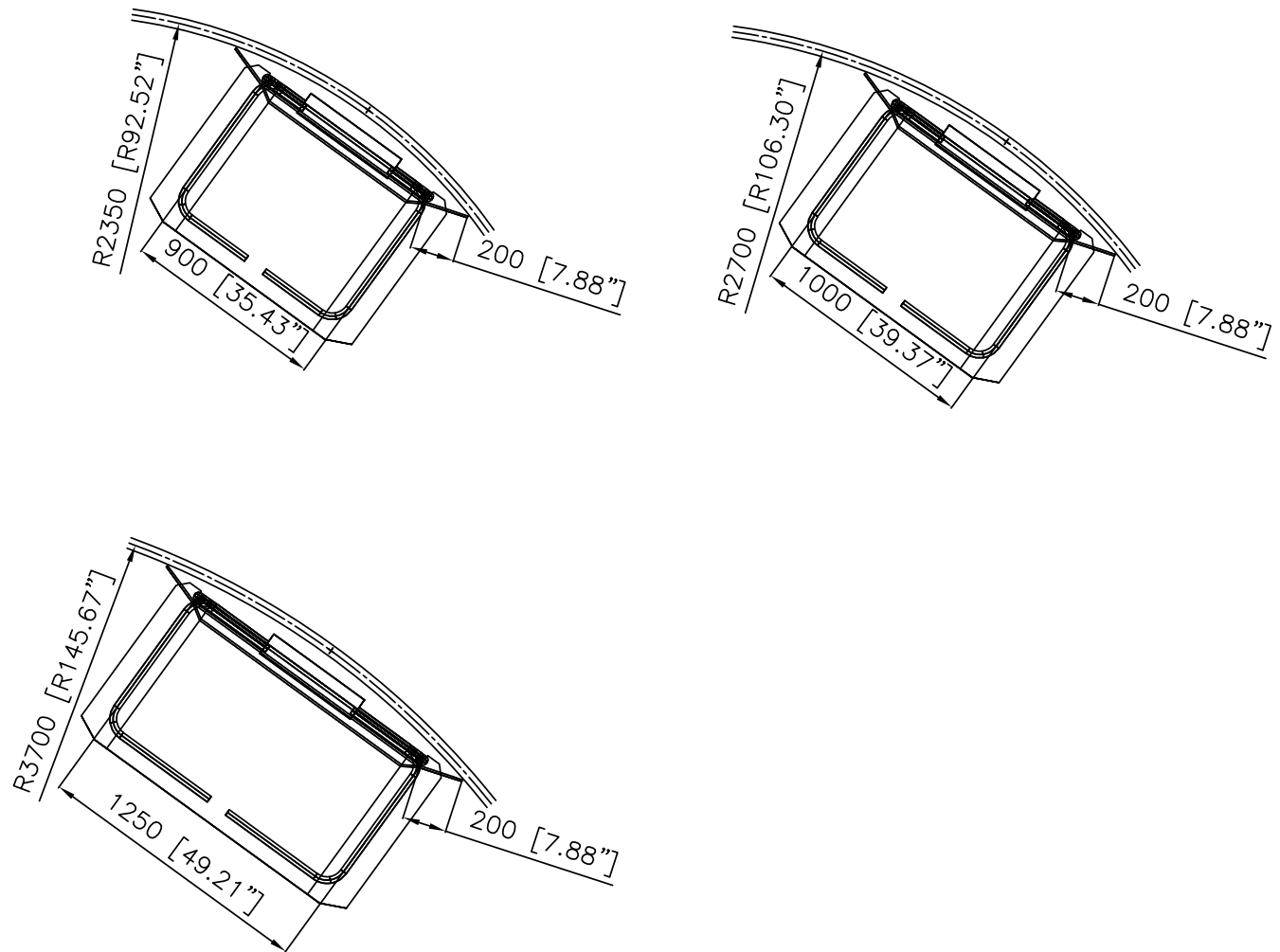

RADIUS OF NEGATIVE CURVE - DEPENDING ON PLATFORM SIZE
RAMP 200mm [7.875"]
DISTANCE PART 50mm [2"]

Standard drive unit clearances

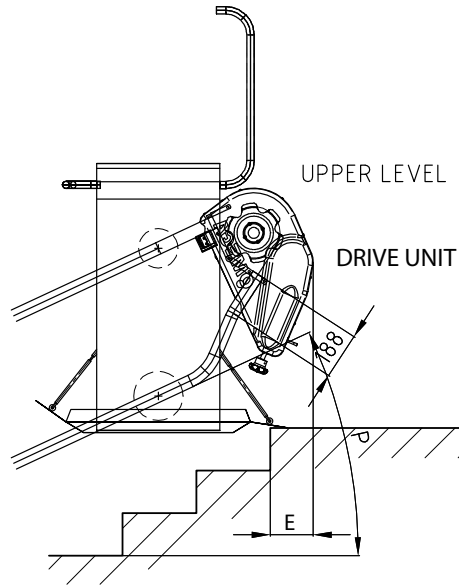

DRIVE UNIT

23°	85/3.3	-75/-3
25°	85/3.3	-75/-3
27°	85/3.3	-75/-3
P	E	E
RAIL ANGLE	L=900/35.5	L=1250/49.25

For reference only; dimensions may vary.
Values in table: mm/inches

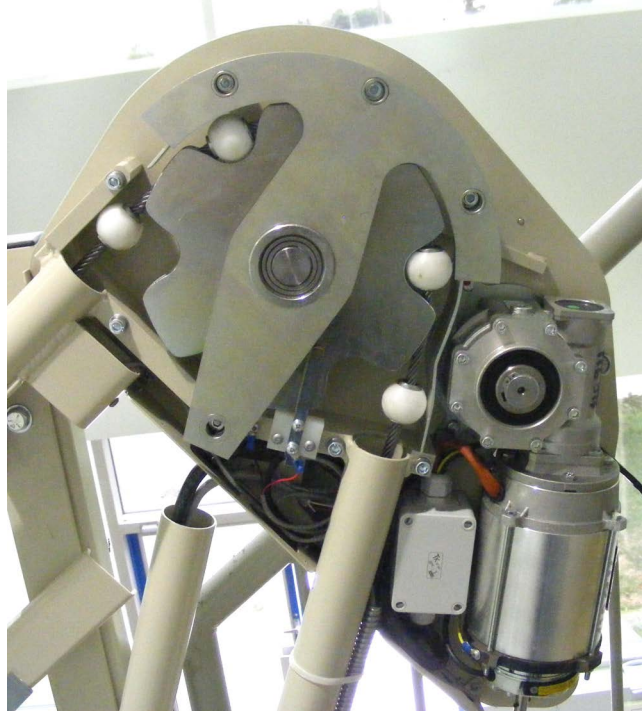

Remote controller box dimensions

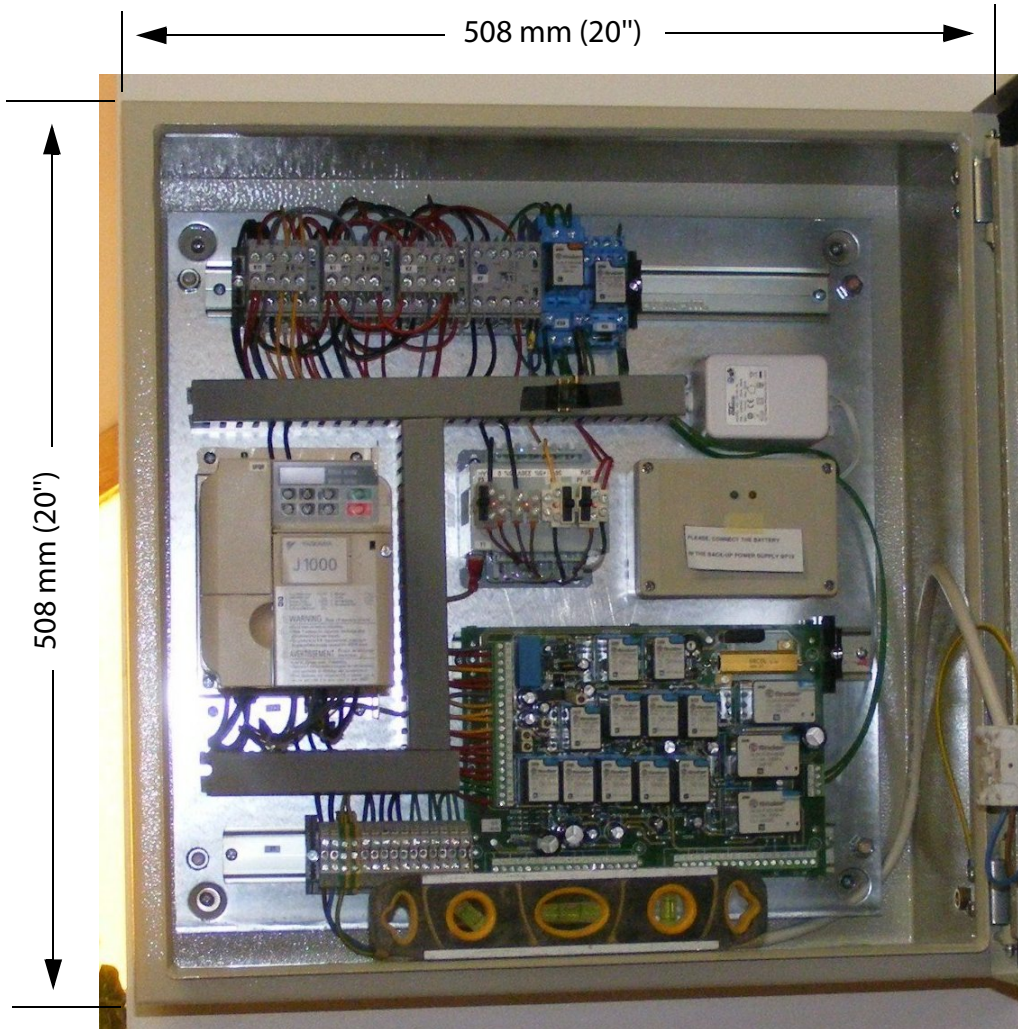

Thickness: 305 mm (12")

Dimensions are for reference only and may vary.

NOTE: It is recommended that the controller box be installed a maximum distance of 30 feet (9.1 metres) from the motor.

Landing light box dimensions

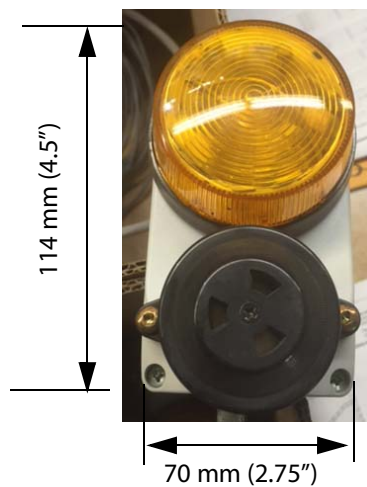

Thickness: 57 mm (2.25")

Optional drive/controller cabinet dimensions (sheet 1)

A31150-000-01
MOTOR: 0,75kW

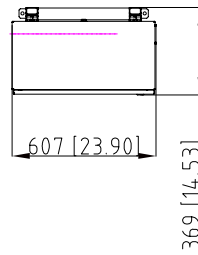
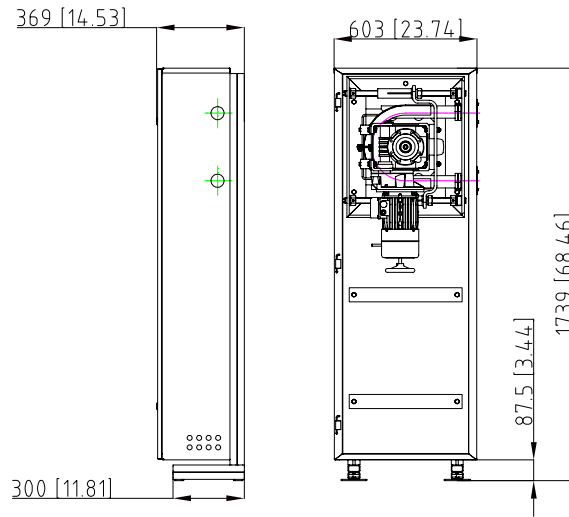

A32240-000-01
MOTOR: 1,1kW

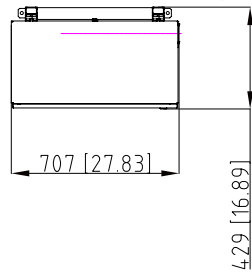
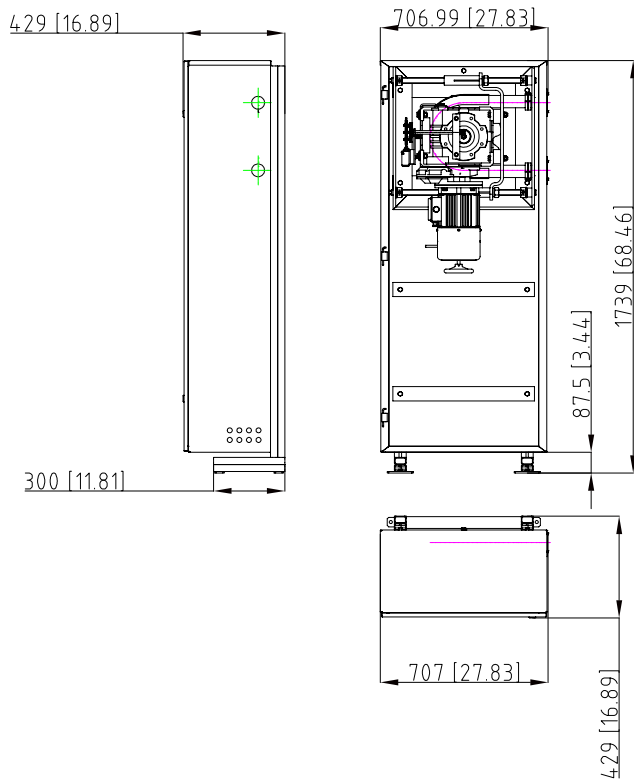

A32120-000-01
MOTOR: 1,1kW

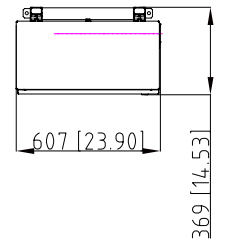
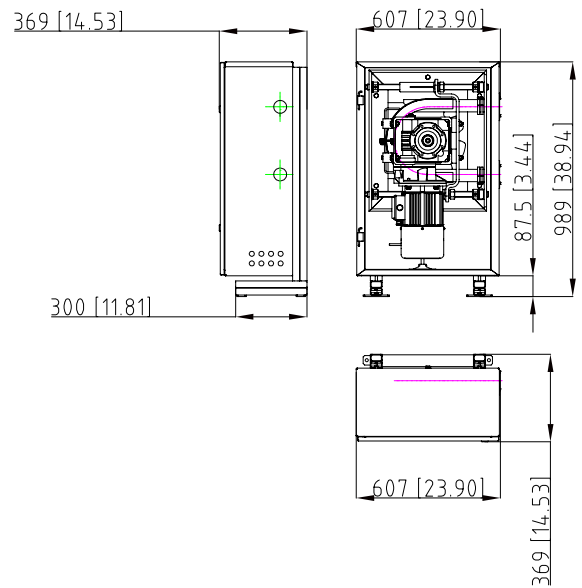

Optional drive/controller cabinet dimensions (sheet 2)

A34240-000-01
MOTOR: 1,5kW

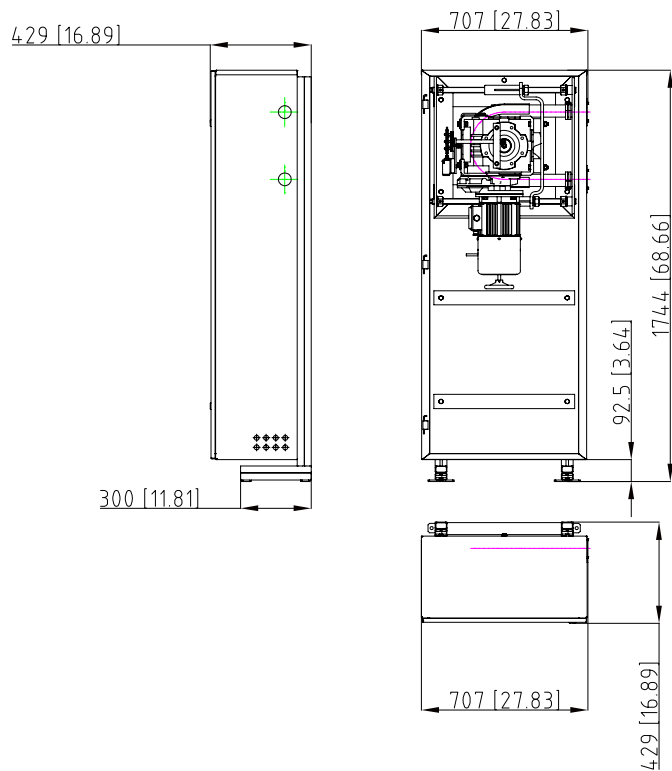

A35240-000-01
MOTOR: 2,2kW

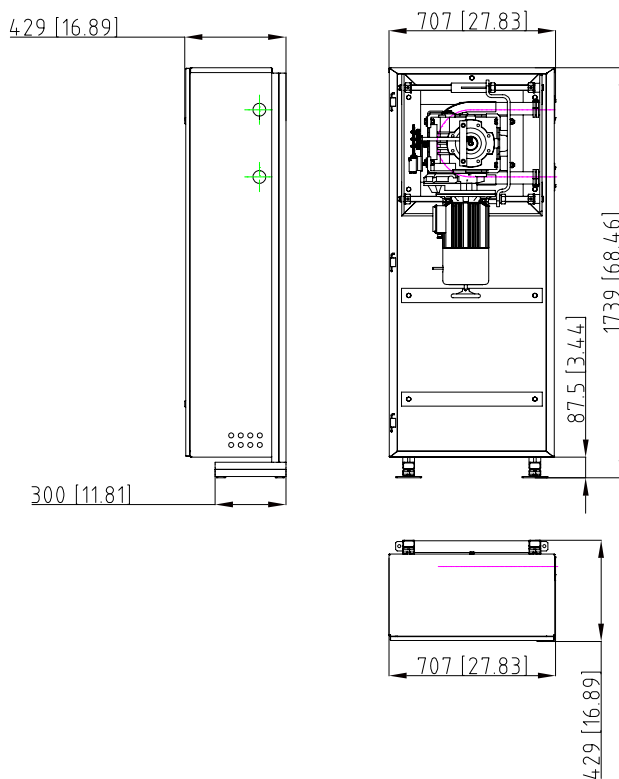

Call station dimensions

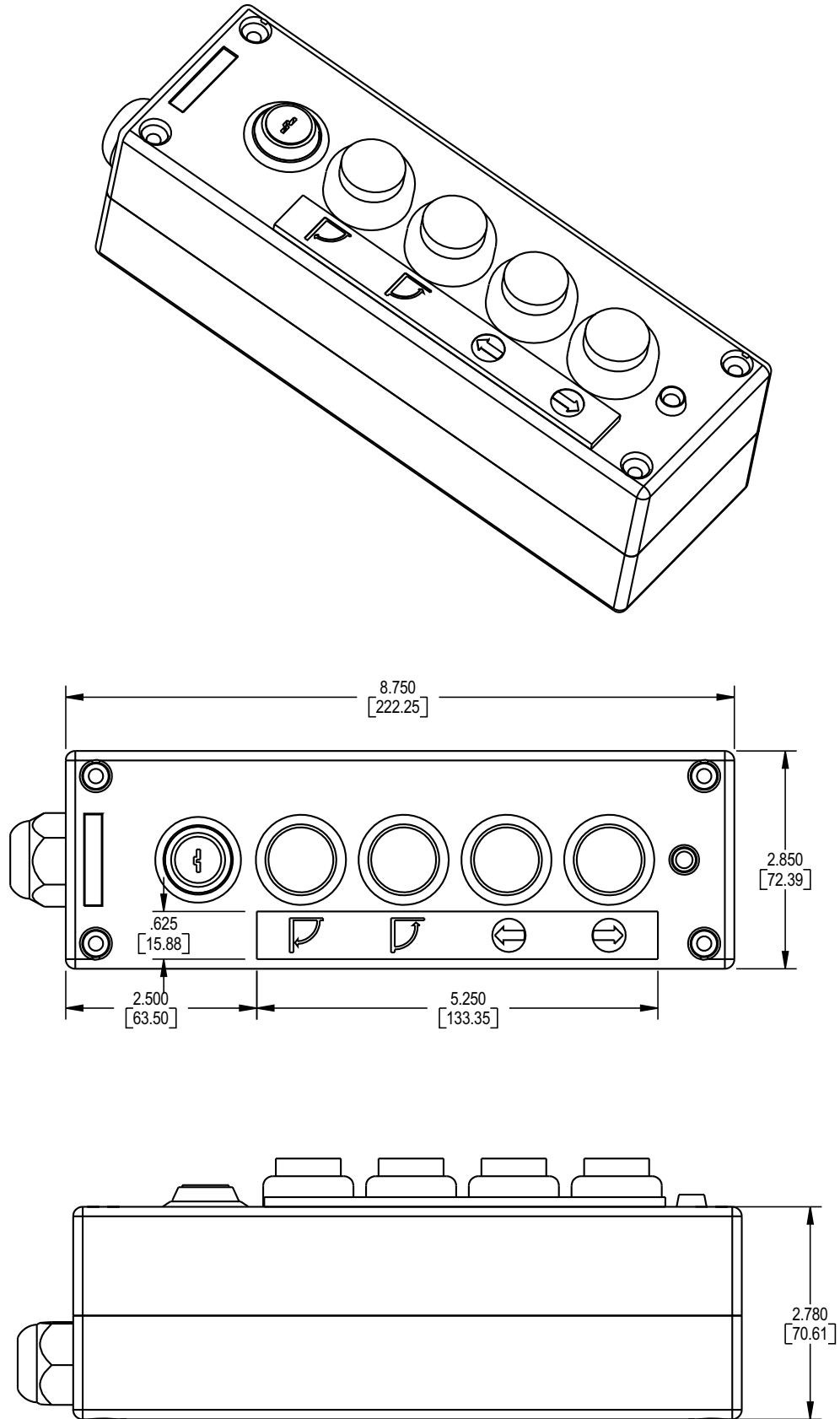

UPS dimensions

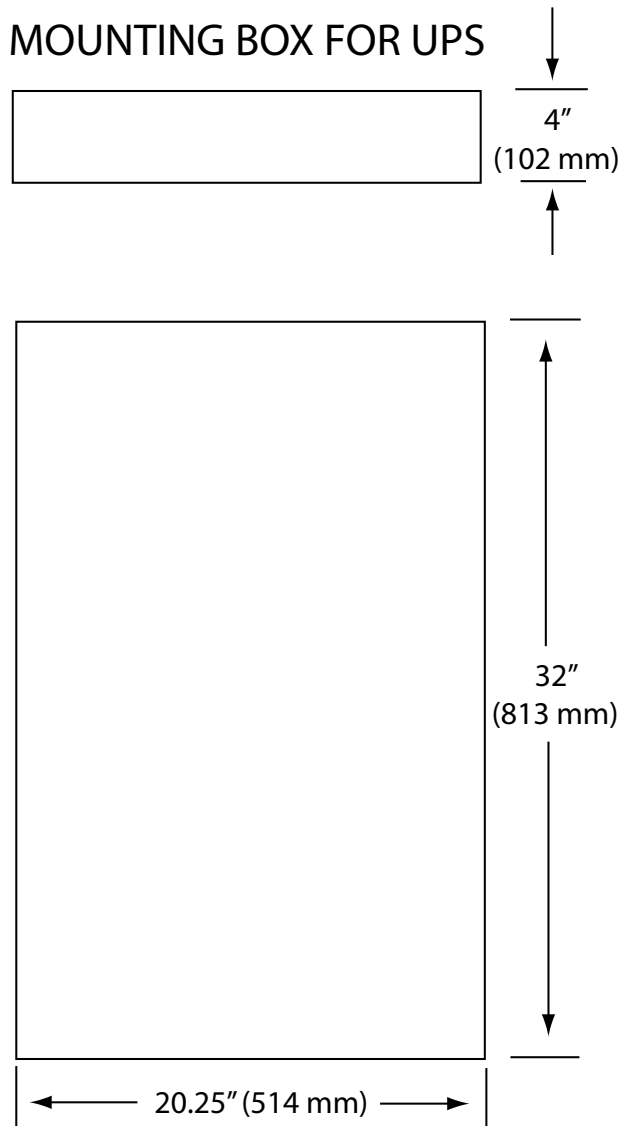
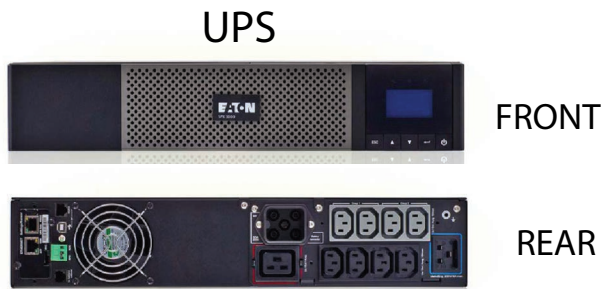

Sample installation wiring layout

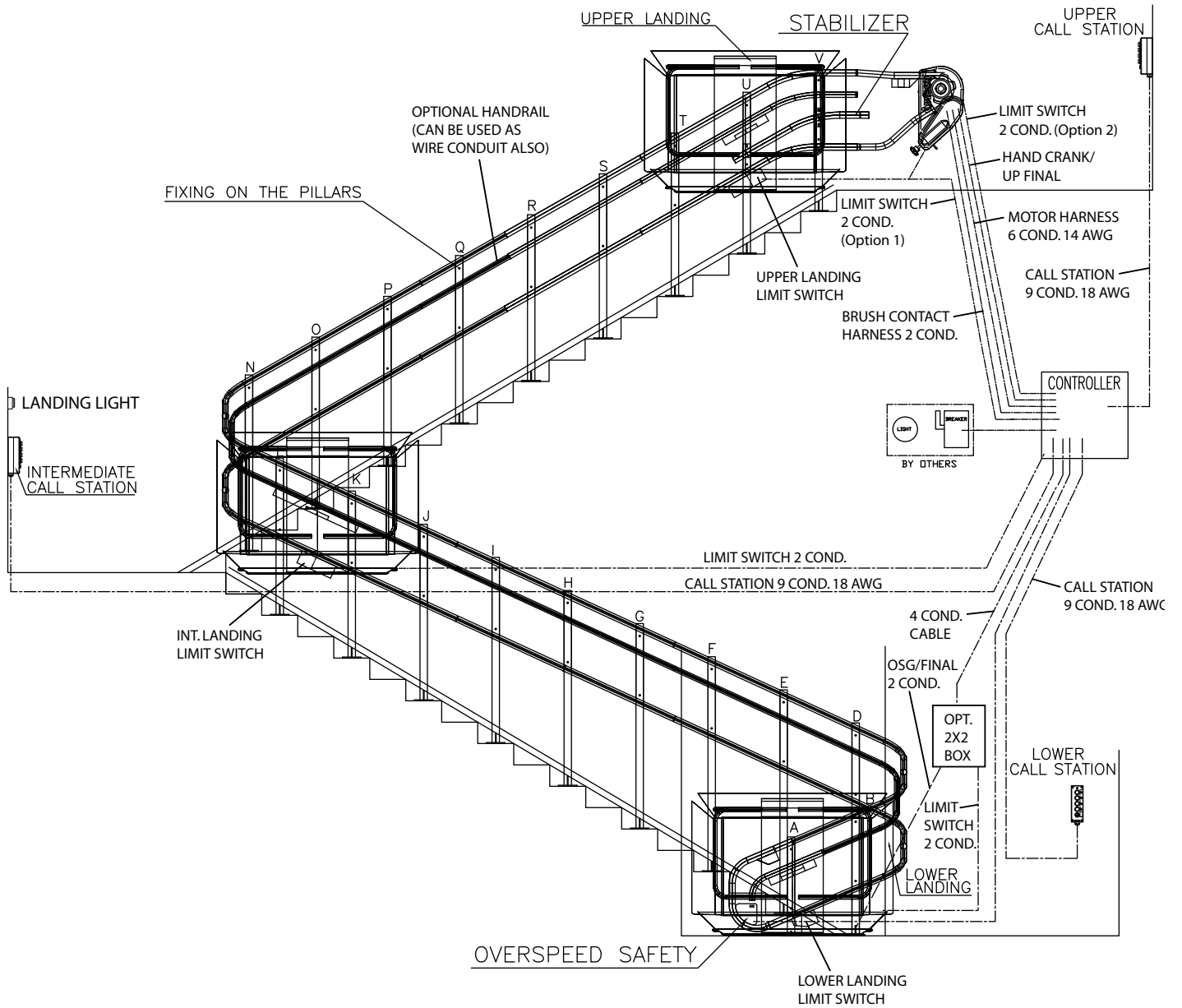

Find more design resources at:

savaria.com

[CAD drawings](#)

[SpecWizard](#)

[Continuing education calendar](#)

Savaria Concord Lifts, Inc.
2 Walker Drive Brampton ON L6T 5E1 Canada

 **savaria.**
savaria.com

©2022 Savaria Corporation